



**NONRESIDENT
TRAINING
COURSE**



February 1993

Equipment Operator, Advanced

NAVEDTRA 14080

Although the words “he,” “him,” and “his” are used sparingly in this course to enhance communication, they are not intended to be gender driven or to affront or discriminate against anyone.

DISTRIBUTION STATEMENT A: Approved for public release; distribution is unlimited.

PREFACE

By enrolling in this self-study course, you have demonstrated a desire to improve yourself and the Navy. Remember, however, this self-study course is only one part of the total Navy training program. Practical experience, schools, selected reading, and your desire to succeed are also necessary to successfully round out a fully meaningful training program.

THE COURSE: This self-study course is organized into subject matter areas, each containing learning objectives to help you determine what you should learn along with text and illustrations to help you understand the information. The subject matter reflects day-to-day requirements and experiences of personnel in the rating or skill area. It also reflects guidance provided by Enlisted Community Managers (ECMs) and other senior personnel, technical references, instructions, etc., and either the occupational or naval standards, which are listed in the *Manual of Navy Enlisted Manpower Personnel Classifications and Occupational Standards*, NAVPERS 18068.

THE QUESTIONS: The questions that appear in this course are designed to help you understand the material in the text.

VALUE: In completing this course, you will improve your military and professional knowledge. Importantly, it can also help you study for the Navy-wide advancement in rate examination. If you are studying and discover a reference in the text to another publication for further information, look it up.

*1993 Edition Prepared by
EOC(SCW) John T. Morris*

Published by
NAVAL EDUCATION AND TRAINING
PROFESSIONAL DEVELOPMENT
AND TECHNOLOGY CENTER

**NAVSUP Logistics Tracking Number
0504-LP-026-7450**

Sailor's Creed

“I am a United States Sailor.

I will support and defend the Constitution of the United States of America and I will obey the orders of those appointed over me.

I represent the fighting spirit of the Navy and those who have gone before me to defend freedom and democracy around the world.

I proudly serve my country's Navy combat team with honor, courage and commitment.

I am committed to excellence and the fair treatment of all.”

CONTENTS

CHAPTER	PAGE
1. Transportation Supervisor	1-1
2. Air Detachment Equipment Supervisor	2-1
3. Crane Crew Supervisor	3-1
4. Projects Supervisor	4-1
5. Quarry Supervisor.	5-1
6. Crusher Supervisor	6-1
7. Concrete Batch Plant Supervisor	7-1
8. Asphalt Plant Supervisor	8-1
9. Well Drilling Supervisor	9-1
APPENDIX	
I. Conversion Tables	AI-1
II. Math Formulas	AII-1
III. References Used to Develop the TRAMAN	AII-1
INDEX	INDEX-1

REGULATIONS ON ENVIRONMENTAL POLLUTION AND HAZARDOUS MATERIALS

Environmental Pollution and Hazardous Waste Handling and Disposal programs have been Enacted and are United States Law. These programs are of immense importance and should be taken into consideration during the planning stages before beginning any new construction or rehabilitation project.

As a member of the Naval Construction Forces, United States law requires you to be constantly aware of potential environmental pollution hazards or hazardous material spills and to report them to your immediate supervisor or other senior personnel at the earliest possible time.

The following list of directives contains information on the cognizant government departments and the procedures for preventing, reporting, and correcting environmental pollution hazards and hazardous materials disposal worldwide:

- **Naval Occupational Safety and Health Program Manual, OPNAVINST 5100.23B**
- **Environmental and Natural Resources Protection Manual, OPNAVINST 5090.1**
- **Domestic Wastewater Control, MIL-HDBK 1005/8**

INSTRUCTIONS FOR TAKING THE COURSE

ASSIGNMENTS

The text pages that you are to study are listed at the beginning of each assignment. Study these pages carefully before attempting to answer the questions. Pay close attention to tables and illustrations and read the learning objectives. The learning objectives state what you should be able to do after studying the material. Answering the questions correctly helps you accomplish the objectives.

SELECTING YOUR ANSWERS

Read each question carefully, then select the BEST answer. You may refer freely to the text. The answers must be the result of your own work and decisions. You are prohibited from referring to or copying the answers of others and from giving answers to anyone else taking the course.

SUBMITTING YOUR ASSIGNMENTS

To have your assignments graded, you must be enrolled in the course with the Nonresident Training Course Administration Branch at the Naval Education and Training Professional Development and Technology Center (NETPDTC). Following enrollment, there are two ways of having your assignments graded: (1) use the Internet to submit your assignments as you complete them, or (2) send all the assignments at one time by mail to NETPDTC.

Grading on the Internet: Advantages to Internet grading are:

- you may submit your answers as soon as you complete an assignment, and
- you get your results faster; usually by the next working day (approximately 24 hours).

In addition to receiving grade results for each assignment, you will receive course completion confirmation once you have completed all the

assignments. To submit your assignment answers via the Internet, go to:

<http://courses.cnet.navy.mil>

Grading by Mail: When you submit answer sheets by mail, send all of your assignments at one time. Do NOT submit individual answer sheets for grading. Mail all of your assignments in an envelope, which you either provide yourself or obtain from your nearest Educational Services Officer (ESO). Submit answer sheets to:

COMMANDING OFFICER
NETPDTC N331
6490 SAUFLEY FIELD ROAD
PENSACOLA FL 32559-5000

Answer Sheets: All courses include one “scannable” answer sheet for each assignment. These answer sheets are preprinted with your SSN, name, assignment number, and course number. Explanations for completing the answer sheets are on the answer sheet.

Do not use answer sheet reproductions: Use only the original answer sheets that we provide—reproductions will not work with our scanning equipment and cannot be processed.

Follow the instructions for marking your answers on the answer sheet. Be sure that blocks 1, 2, and 3 are filled in correctly. This information is necessary for your course to be properly processed and for you to receive credit for your work.

COMPLETION TIME

Courses must be completed within 12 months from the date of enrollment. This includes time required to resubmit failed assignments.

PASS/FAIL ASSIGNMENT PROCEDURES

If your overall course score is 3.2 or higher, you will pass the course and will not be required to resubmit assignments. Once your assignments have been graded you will receive course completion confirmation.

If you receive less than a 3.2 on any assignment and your overall course score is below 3.2, you will be given the opportunity to resubmit failed assignments. **You may resubmit failed assignments only once.** Internet students will receive notification when they have failed an assignment--they may then resubmit failed assignments on the web site. Internet students may view and print results for failed assignments from the web site. Students who submit by mail will receive a failing result letter and a new answer sheet for resubmission of each failed assignment.

COMPLETION CONFIRMATION

After successfully completing this course, you will receive a letter of completion.

ERRATA

Errata are used to correct minor errors or delete obsolete information in a course. Errata may also be used to provide instructions to the student. If a course has an errata, it will be included as the first page(s) after the front cover. Errata for all courses can be accessed and viewed/downloaded at:

<http://www.advancement.cnet.navy.mil>

STUDENT FEEDBACK QUESTIONS

We value your suggestions, questions, and criticisms on our courses. If you would like to communicate with us regarding this course, we encourage you, if possible, to use e-mail. If you write or fax, please use a copy of the Student Comment form that follows this page.

For subject matter questions:

E-mail: n314.products@cnet.navy.mil
Phone: Comm: (850) 452-1001, Ext. 1826
DSN: 922-1001, Ext. 1826
FAX: (850) 452-1370
(Do not fax answer sheets.)
Address: COMMANDING OFFICER
NETPDTC (CODE N314)
6490 SAUFLEY FIELD ROAD
PENSACOLA FL 32509-5237

For enrollment, shipping, grading, or completion letter questions

E-mail: fleetservices@cnet.navy.mil
Phone: Toll Free: 877-264-8583
Comm: (850) 452-1511/1181/1859
DSN: 922-1511/1181/1859
FAX: (850) 452-1370
(Do not fax answer sheets.)
Address: COMMANDING OFFICER
NETPDTC (CODE N331)
6490 SAUFLEY FIELD ROAD
PENSACOLA FL 32559-5000

NAVAL RESERVE RETIREMENT CREDIT

If you are a member of the Naval Reserve, you will receive retirement points if you are authorized to receive them under current directives governing retirement of Naval Reserve personnel. For Naval Reserve retirement, this course is evaluated at 9 points. (Refer to *Administrative Procedures for Naval Reservists on Inactive Duty*, BUPERSINST 1001.39, for more information about retirement points.)

COURSE OBJECTIVES

This course provides the basic information required for Advanced Equipment Operators to perform the duties and responsibilities in the following positions: Transportation Supervisor; Air Detachment Equipment Supervisor; Crane Crew Supervisor; Project Supervisor; Quarry Supervisor; Crusher Supervisor; Concrete Batch Plant Supervisor; Asphalt Plant Supervisor; and Well Drilling Supervisor.

Student Comments

Course Title: Equipment Operator, Advanced

NAVEDTRA: 14080 **Date:** _____

We need some information about you:

Rate/Rank and Name: _____ SSN: _____ Command/Unit _____

Street Address: _____ City: _____ State/FPO: _____ Zip _____

Your comments, suggestions, etc.:

Privacy Act Statement: Under authority of Title 5, USC 301, information regarding your military status is requested in processing your comments and in preparing a reply. This information will not be divulged without written authorization to anyone other than those within DOD for official use in determining performance.

NETPDTC 1550/41 (Rev 4-00)

CHAPTER 1

TRANSPORTATION SUPERVISOR

The Navy has millions of dollars invested in transportation and construction equipment. In the Naval Construction Force (NCF), equipment represents more than 70 percent of the total NCF outfitting cost.

Equipment is the “backbone” of the Seabees. The enforcement of instructions to ensure proper management and supervision of equipment operations starts with the first-class community.

This chapter presents the responsibilities of an Equipment Operator assigned to provide supervision of a construction and automotive equipment pool at the Naval Mobile Construction Battalion (NMCB) level.

TRANSPORTATION SUPERVISOR RESPONSIBILITIES

The responsibilities of the transportation supervisor are to supervise and control operations, operator maintenance, and the cycle of automotive, construction, and weight-handling equipment. Also, the transportation supervisor ensures the transportation pool supports the transport of personnel, equipment, and materials, and maintains and operates all fuel, petroleum oil, and lubricant storage and dispensing facilities.

The basic goal of the transportation supervisor is to ensure that safe and serviceable equipment is available for use and the maximum service life of the equipment is achieved.

EQUIPMENT MANAGEMENT INSTRUCTIONS

Instructions and publications have been established to regulate the management and control of equipment. Equipment and supplies procured for the Navy are assigned to various inventory managers. Major construction equipment, automotive equipment, specialized equipment, amphibious gear, and civil engineer support equipment (CESE) are classed as 2C materials. The Naval Facilities Engineering Command (NAVFACENGCOM) is the inventory manager for all 2C material in the Navy.

The Civil Engineer Support Office (CESO) at the Naval Construction Battalion Center, Port Hueneme, California, has the management responsibility for 2C materials.

Management of Transportation Equipment, NAVFAC P-300

To supervise a transportation pool properly, you must be knowledgeable of the applicable publications and instructions.

The NAVFAC P-300 was developed for the management of equipment in a stable environment. The NAVFAC P-300 is a compilation of directives issued by the Secretary of the Navy (SECNAV), the Chief of Naval Operations (CNO), and the Commander, Naval Facilities Engineering Command (COMNAVFACENGCOM). NAVFAC P-300 provides general and detailed procedures for the administration, operation, and maintenance of transportation equipment. The areas included are as follows: administration, procurement, rental, charter, assignment, loan, utilization, registration, and technical record control. Additionally, NAVFAC P-300 provides instructions for the disposition of and the operational procedures for automotive, construction, railroad, and special category transportation equipment. Procedures are included for maintenance planning, scheduling, maintenance control, material support, equipment modification, painting, identification markings, protective coatings, and selection and application of fuels and lubricants.

Equipment Management Manual, NAVFAC P-404

The NAVFAC P-404 establishes criteria, policies, and procedures for the management of CESE assigned to the Naval Construction Force (NCF), Special Operating Units (SOUs), and the Naval Construction Training Centers (NCTCs). The NAVFAC P-404 meets the needs of the NCF and the SOUs. These organizations are required to perform projects in a variety of extreme conditions while experiencing a constant turnover of personnel who require specific procedural direction.

**Naval Mobile Construction Battalion
(NMCB) Equipment Management
Instruction, COMSECON/COMTHIRDNCBINST 11200.1 Series**

administration, operation, and maintenance of automotive and construction equipment.

**Naval Construction Force Manual,
WV FAC P-315**

The COMSECON/COMTHIRDNCBINST 11200.1 Series contains policies and procedures to assist personnel concerned with the management of equipment in units under Second and Third Naval Construction Brigade (NCB), or reserve NCB operational and administrative control. The intent is to assist all levels of personnel to accomplish assigned responsibilities in an efficient manner. Divided into four parts, the instruction provides a convenient directory to locate information or procedures for the

This manual provides technical guidance from the Chief of Civil Engineers regarding the organization and operation of the NCF. The manual is divided into two distinct parts. The first part presents an overview of the NCF, including reserve NCF, and the organizational structure and functional roles of key members of an NMCB. The second part describes the mission, organizational structure, and concepts of operation for NCF units other than the NMCB, and describes the commands involved with NCF support.

FACSO RPT SYM,NO 11201/FB221R01													
EQUIPMENT / ATTACHMENT TAB													
RECORD HOLDER N57034 COMBLANT LITTLE CREEK VA													
LOCATION EUS: P25 EUROPEAN SEA ECHELON													
EQUIP CODE	USN OR ATTACHMENT	ECC DESCRIPTION	MANUFACTURER	MODEL	MFR YR	WEIGHT	LEN	WID	HIG	CUBE	MEAS TONS	SO FEET	REMARKS
	T20AD2003	ANGLE DOZER	INT HAR	T020	70		20	156	46	83	2	21	N6/074;26FEB87
	T20AD2039	ANGLE DOZER	IHC	T020BP	67		135	27	103	103	2	25	ONELTR5200/SER3
	T20RP2006	RIPPER	AMERTRAC	HRTD20B	68	1728	72	90	84	315	7	45	FOURMSG280922ZN
	T20WH2002	WINCH DRUM	PACARFDY	T020B	70		39	45	42	43	1	12	N6/074;26FEB87
	10B411016	BUCKET 4 IN 1	DROTT	955K	68	375	89	48	57	141	3	29	N6/240/12AUG86
	32FL1055	FAIRLEAD CRANE	THEW	MC32M	66	285	33	30	29	17		6	HUELTRSER3706/1
030731	94-17102	TRK 3/4T UTIL	GMC/TRK	M1009	84	5200	191	85	75	705	17	112	DD1342 DTD 8710
	94-17104	TRK 3/4T UTIL	GMC/TRK	M1009	84	5200	191	85	75	705	17	112	62MSG2313062SEP
	94-17967	TRK 3/4T UTIL	GMC/TRK	M1009	84	5200	192	86	75	717	17	114	62MSG2313062SEP
	94-17968	TRK 3/4T UTIL	GMC/TRK	M1009	84	5200	191	85	75	705	17	112	62MSG2313062SEP
	94-17969	TRK 3/4T UTIL	GMC/TRK	M1009	84	5200	192	86	75	717	17	114	62MSG2313062SEP
	94-17970	TRK 3/4T UTIL	GMC/TRK	M1009	84	5200	191	85	75	705	17	112	62MSG2313062SEP
034812	95-23194	TRK 1T PICKUP	CHRYSLER	W200	78	5022	217	80	77	774	19	120	74MSG101526ZJAN
	95-23198	TRK 1T PICKUP	CHRYSLER	W200	78	5022	217	80	77	774	19	120	74MSG101526ZJAN
	95-23199	TRK 1T PICKUP	CHRYSLER	W200	78	5022	217	80	77	774	19	120	74MSG261407ZFEB
	95-23200	TRK 1T PICKUP	CHRYSLER	W200	78	5022	217	80	77	774	19	120	74MSG050946ZFEB
	95-23203	TRK 1T PICKUP	CHRYSLER	W200	78	5022	217	80	77	774	19	120	74MSG050946ZFEB
	95-23207	TRK 1T PICKUP	CHRYSLER	W200	78	5022	217	80	77	774	19	120	74MSG050946ZFEB
	95-23212	TRK 1T PICKUP	CHRYSLER	W200	78	5022	217	80	77	774	19	120	74MSG271506ZMAR
	95-23214	TRK 1T PICKUP	CHRYSLER	W200	78	5022	217	80	77	774	19	120	74MSG050946ZFEB
036131	94-17709	AMBULANCE HEAVY	GMC/TRK	M1010	84	7370	227	91	102	1219	30	143	DD1342 DTD 8718
053901	96-39252	TRK 2 1/2T CARG	JEEP CORP	M35A2C	84	13100	265	96	112	1649	41	176	NMCB62MSG021206
	96-39261	TRK 2 1/2T CARG	JEEP CORP	M35A2C	84	13100	265	96	112	1649	41	176	NMCB62MSG021206
	96-39262	TRK 2 1/2T CARG	JEEP CORP	M35A2C	84	13100	265	96	112	1649	41	176	NMCB62MSG021206
	96-39263	TRK 2 1/2T CARG	JEEP CORP	M35A2C	84	13100	265	96	112	1649	41	176	NMCB62MSG021206
	96-39264	TRK 2 1/2T CARG	AM GEN	M35A2C	84	13100	265	96	112	1649	41	176	NMCB62MSG021206
060700	96-31740	TRK 5T TRACTOR	JEEP CORP	M52A2	69	17410	257	98	111	1618	40	174	NMCB133LTRSER A
	96-32661	TRK 5T TRACTOR	JEEP CORP	M52A2	69	17410	257	98	111	1618	40	174	DD1342 DTD 8819
060701	96-37485	TRK 5T TRACTOR	AM GEN	M818	79	20290	264	97	103	1526	38	177	ONE MSG 210900Z
	96-37486	TRK 5T TRACTOR	AM GEN	M818	79	20290	264	97	103	1526	38	177	ONE MSG 210900Z
064411	96-34576	TRK 20T DUMP	INT H CD	F5070	75	31000	300	101	132	2315	57	210	DD1342 DTD 8720
	96-34580	TRK 20T DUMP	INT H CD	F5070	76	31000	300	101	132	2315	57	210	DD1342 DTD 8720

Figure 1-1.—A section of an Equipment TAB A.

**CONSTRUCTION AUTOMOTIVE
SPECIAL EQUIPMENT/MANAGEMENT
INFORMATION SYSTEM**

The Construction Automotive Special Equipment/Management Information System (CASE/MIS) is a computer program used for management and procurement of all CESE. The Civil Engineer Support Office (CESO), Port Hueneme, maintains this program. Second and Third NCB equipo offices use the (CASE/MIS) program to perform on-hands management of CESE assignment, replacement, overhaul, and disposal. Information maintained by CASE/MIS is discussed in the following paragraphs.

TAB A

This equipment list is initiated by CESO and is updated by the Second and Third NCB equipo office from the CASE/MIS computer program. The TAB A is printed in any format requested by on-site managers. The basic format (fig. 1-1) is printed showing the equipment code, USN, description, and location.

Equipment Code (EC)

CESO assigns an Equipment Code (EC) for each type of equipment (see table 1-1). The primary purpose of equipment codes is to establish permanent and positive identification of each unit of CESE. For

example, you have six sedans on a TAB A with the 92-00000 series USN numbers, and one of the six sedans is equipped with air conditioning. The standard EC for sedans is 0105/01. Five of the sedans are listed under the 0105/01 EC. The sedan equipped with air conditioning is listed under a special EC of 0105/02 because the last two digits of a EC denotes any special procurement for a piece of equipment.

DISPATCHER

The transportation supervisor must possess an in-depth knowledge of the positions that work together to make the transportation pool function effectively. The dispatch office is the hub of communication for all equipment-related matters; therefore, a dispatcher must have the ability to convey information and instructions in a clear and tactful manner.

The dispatcher controls the status and location of every assigned item of equipment. The dispatcher controls the keys to all vehicle-locking devices, and all spare keys are retained in the equipment history jacket. The dispatcher also maintains all required forms and records for assigned equipment.

Equipment Status Board

The primary function of the equipment status board is to serve as a visual aid that provides a list of all equipment assigned to the unit. The board should

Table 1-1.—Equipment Codes

EC Number	Type of Equipment
0001/00 through 0999/99	Cars, trucks, trailers, and other hauling equipment equipped with wheels
1000/00 through 1999/00	Includes all forklift equipment. The Naval Supply Systems Command controls the inventory in this standard allowance.
2000/00 through 9999/99	All construction equipment which includes the following: dozers; conveyors; cranes; excavating equipment; crushers; asphalt plants; concrete plants; and specialty hauling equipment; such as water, asphalt, and cement trucks

*	Code	USN	Description	Location	PM Group	Remarks
(1)	030700	94-88650	Trk 1 4T Util	A CO CDR	37	
(1)	036000	95-19190	Trk 1-1/4T Cargo	Pool	1	
(2)		95-21098		Ops Supervisor	21	Shop 2.20 Deadlined 2.24
(1)	053900	95-16749	Trk 2-1/2T Cargo		2	
(3)	058700	96-27071	Trk 5T Dump	UT Project	3	Excess Ltr 4570 Ser XXX
(3)		96-27072		Pool	23	Excess Ltr 4570 Ser XXX
(4)		96-33439				Due 3.3 Ltr 4610 Ser XXX
(4)		96-33451				Due 3.3 Ltr 4610 Ser XXX
(1)	058800	96-32607	Trk 5T Cargo	UT Project	7	
(1)	060700	96-32926	Trk 5T TT	Pool	5	
(1)	073000	96-36101	Trk Wrecker	Heavy Shop	11	

* Optional column for color disc usage

Legend

- (1) Black — In-service, Operational
- (2) Red — Deadline
- (3) Green — Pending Replacement
- (4) Orange — Ordered in
- (5) Blue — Optional Detachment, Etc.

Figure 1-2.—Equipment Status Board.

be color-coded to identify the CESE current status, general assignment, and location (fig. 1-2).

The dispatcher **must** know the current status and location of every assigned item of CESE by maintaining the status board and making a comparison check **daily** between the dispatch equipment status board and the equipment status board of cost control.

Dispatcher Logs

The dispatcher maintains and records all vehicles and equipment dispatched on the Dispatcher's Log, NAVFAC 9-11240/2 (fig. 1-3). Dispatchers maintain a Heavy Equipment Log, a Class B CESE assigned log, and a Class C assigned log. Class C and Heavy Equipment Logs are closed out, folded, and stapled

shut daily. The Class B assigned log is closed out weekly. The Operator's Daily PM Report, NAVFAC 11260/4 (fig. 1-4), is used for logging construction equipment. The Operator's Inspection Guide and Trouble Report, NAVFAC 9-11240/13 (fig. 1-5), and Motor Equipment Utilization Record, DD Form 1970 (Trip Ticket) (figs. 1-6 and 1-7), is used for logging Type B and C CESE. The reports and records are enclosed in the appropriate folded Dispatcher's Log. On the outside of the log, the dispatcher records the date and total operating hours or total mileage of all CESE dispatched.

On the first day of each week, the transportation supervisor collects the Dispatcher's Logs for the Alfa company operations supervisor. When you perform this task, ensure the following:

1. All forms are completed according to Second and Third NCB current instructions.

OPERATOR'S DAILY PM REPORT NAVFAC 11260/4 (9-74) Supersedes NAVDOCKS 2664 S/N 0105-LF-004-1520			USN NO. 44-01695
Use Reverse Side for Remarks Explanatory Notes on Reverse Side.			FUEL OPR HRS N/A
NO.	ITEM	OK ✓	SERVICES PERFORMED
1	RADIATOR SOLUTION	✓	
2	GEN. & FAX BELT	✓	
3	ENGINE OIL LEVEL		ADDED 1 QT.
4	AIR CLEAMER	✓	
5	PRECLEAMER	✓	
6	BATTERY	✓	
7	HYD. OIL LEVEL	✓	
8	LUBRICATION	✓	
9	TIRE CONDITION	✓	CHG RIGHT FRONT
10	SAFETY EQUIP.	✓	
11	GENERAL COND.	✓	
12	FUEL LEVEL	✓	
13	INSTRUMENTS	✓	
14	SHUTDOWN PRECAUTIONS	✓	
15	OTHER		
DATE		OPERATOR'S SIGNATURE	
1 May 1988			

VOID AFTER
 HOUR
 DATE

Figure 1-4—Operator's Daily PM Report, NAVFAC 9-11260/4.

OPERATOR'S INSPECTION GUIDE AND TROUBLE REPORT	
REGISTRATION NO. 94-75111	ODOMETER READING 7581
Use this form as a guide when performing before and after operation inspections. Check (✓) items that require servicing by maintenance personnel.	
<input type="checkbox"/>	1. DAMAGE (Exterior, Interior, Missing Components)
<input checked="" type="checkbox"/>	2. LEAKS (Oil, Gas, Water)
<input type="checkbox"/>	3. TIRES (Check inflation, abnormal wear)
<input type="checkbox"/>	4. FUEL, OIL, WATER SUPPLY (Antifreeze in season)
<input type="checkbox"/>	5. BATTERY (Check water level, cables, etc.)
<input type="checkbox"/>	6. HORN
<input type="checkbox"/>	7. LIGHTS/REFLECTORS/MIRRORS/TURN SIGNALS
<input type="checkbox"/>	8. INSTRUMENTS (Oil, Air, Temperature, etc.)
<input type="checkbox"/>	9. WINDSHIELD WIPER
<input type="checkbox"/>	10. CLEAN WINDSHIELD/VEHICLE INTERIOR
<input type="checkbox"/>	11. CARGO, MOUNTED EQUIPMENT
<input type="checkbox"/>	12. STEERING
<input type="checkbox"/>	13. SAFETY DEVICES (Seat belts, flares, etc.)
<input type="checkbox"/>	14. DRIVE BELTS/PULLEYS
<input type="checkbox"/>	15. BRAKES (Drain air tank when equipped)
<input type="checkbox"/>	16. OTHER (Specify in "Remarks")
DATE 1 June 1988	OPERATOR'S SIGNATURE
REMARKS OIL LEAK BOTTOM OF OIL PAN	
<small>NAVFAC 9-11240.13 (12-69) Supersedes DD Form 1358 S/N 0105-LF-004-1195</small>	

Figure 1-5.—Operator's Inspection Guide and Trouble Report, NAVFAC 9-11240/13.

2. The dispatcher has provided accurate usage (miles or hours).
3. Balance and track high-mileage and low-mileage vehicles for possible reassignments or vehicle misuse.

After reviewing the forms, you initial the logs to show the operations supervisor that you have reviewed them. The operations supervisor reviews the logs as required by the COMSECOND/COMTHIRDNBINST 11200.1 Series instructions.

In the NCF, the logs are retained on file by the dispatchers for a period of 90 days. At a public works, the DD Form 1970 is retained for 90 days and the Dispatcher Logs retained for 36 months.

OFF STATION

MOTOR EQUIPMENT UTILIZATION RECORD							
DATE (YYMMDD)	TYPE OF EQUIPMENT		REGISTRATION NO./SERIAL NO.			ADMINISTRATION NO.	
ORGANIZATION NAME	ACTION	TIME	MILES	HOURS	FUEL	OIL	
1ST OPERATOR (Last Name, First, M.I.)	IN				REPORT TO (Last Name, First, M.I.)	AS DIRECTED	
OPERATOR'S SIGNATURE	OUT				DISPATCHER'S SIGNATURE		
	TOTAL						
2D OPERATOR (Last Name, First, M.I.)	IN				REPORT TO (Last Name, First, M.I.)		
OPERATOR'S SIGNATURE	OUT				DISPATCHER'S SIGNATURE		
	TOTAL						
3D OPERATOR (Last Name, First, M.I.)	IN				REPORT TO (Last Name, First, M.I.)		
OPERATOR'S SIGNATURE	OUT				DISPATCHER'S SIGNATURE		
	TOTAL						
4TH OPERATOR (Last Name, First, M.I.)	IN				REPORT TO (Last Name, First, M.I.)		
OPERATOR'S SIGNATURE	OUT				DISPATCHER'S SIGNATURE		
	TOTAL						
DESTINATION	TIME		RELEASED BY		REMARKS		
	ARRIVE	DEPART	(Signature)				
FROM							
1.							
TO							
2.							
TO							
3.							
TO							
4.							
TO							
5.							
TO							
6.							
TO							
7.							
TO							
8.							
TO							
9.							
TO							
10.							
TO							
11.							
TO							
12.							
TO							
13.							
TO							
14.							
TO							
15.							
TO							
16.							

DD FORM 81 APR 1970 SN 0102-LF-001-9701

(Continue on Reverse)

PREVIOUS EDITIONS MAY BE USED

* GPO: 1986-687-021/50456

WASH VEHICLE
DAILY AND
PRIOR TO
TURN IN

VOID AFTER
HOUR=
DATE=

Figure 1-6.—Motor Vehicle Utilization Record, DD Form 1970 (Front).

TO 17.				
TO 18.				
TO 19.				
TO 20.				
TO 21.				
TO 22.				
TO 23.				
TO 24.				
TO 25.				
TO 26.				
TO 27.				
TO 28.				
TO 29.				

INSTRUCTIONS

* 1. *Date.* Enter the calendar date the equipment is to be used.

2. *Type of Equipment.* Enter the type of equipment as designated in the equipment log.

3. *Registration Number or Serial Number.* Enter the equipment registration number or serial number.

4. *Administration Number.* Enter the unit bumper or administrative number.

5. *Organization Name.* Enter the organization to which the equipment is assigned.

6. *Operator.* Enter the name of the equipment operator.

7. *Operator's Signature.* The equipment operator (item 6) will enter signature immediately upon receipt of equipment.

* 8. *Time.* Indicate time to the nearest 5 minutes using the 24-hour clock.

- a. *In.* Enter time equipment was returned from dispatch or use.
- b. *Out.* enter the time the equipment was released for operation by the dispatcher.
- c. *Total.* Enter total time the equipment was in the possession of the operator. Time is obtained by subtracting the time listed in "Out" line from that listed on the "In" line.

* 9. *Miles.* Will be recorded to the nearest whole mile.

- a. *In.* the operator will enter the mileage reading when the equipment is returned. If odometer is inoperative, enter estimated mileage.
- b. *Out.* The dispatcher will enter the mileage reading as the time of dispatch.
- c. *Total.* Enter the difference between the "Out" and "In" mileage.

*10. *Hours.* Will be recorded to the nearest whole hour. On those items which require servicing on an hourly basis and are not equipped with an hour meter, enter the estimated hours of operation.

- a. *In.* The operator will enter the hour meter reading upon completion of the equipment usage.
- b. *Out.* The dispatcher will enter the hour meter reading prior to equipment release.
- c. *Total.* Enter the total hours dispatched for operation.

11. *Fuel/Oil.* Enter the amount of fuel (gallons) and/or oil (quarts) obtained for the equipment.

*12. *Report To.* Enter the name of the individual to whom the operator is to report.

13. *Dispatcher's Signature.* Self-explanatory.

14. *Destination.* Indicate each location at which a trip begins and ends. Normally this starts from the equipment pool. ("From" Line) and ends at the same place after one or more intervening destinations.

*15. *Time.* All time will be recorded using the 24-hour clock, rounded off to the nearest 5 minutes.

- a. *Arrive.* Enter the arrival time at each destination.
- b. *Depart.* Enter the departure time from the motor pool and each succeeding location.

16. *Released By.* The person in charge of equipment on dispatch will release by signing on the line indicating the destination where the equipment was released to the operator. Upon termination of equipment used, but not moved, the person in charge will release the equipment by signing in the top block of this column.

17. *Remarks.* The remarks column will be used by the operator to record unusual operation or abnormal occurrences during operation, or other information as directed.

Items marked with an asterisk () have been registered in the DOD Data Element Program.

Figure 1-7.—Motor Vehicle Utilization Record, DD Form 1970 (Back)

Trouble Reports File (Hard-Card File)

The dispatcher maintains a Trouble Reports File for the NAVFAC 9-11240/13 (Hard Card) and the NAVFAC 11260/4 (Operator's Daily PM Report) by preventive maintenance intervals. The standard interval between PM service inspections for NCF equipment is 40 working days. Therefore, the Trouble Reports File is divided into 40 PM group sections, covering each of these working days.

The dispatcher issues NAVFAC 9-11240/13 and NAVFAC 11260/4 to operators to document pre and post operations of equipment. The yard boss enforces the "operator's daily" before, during, and after operational inspections to include lubrications and adjustments. Repairs, above the operator's area of responsibility not requiring immediate attention and are not a safety-related item, are logged on either the NAVFAC 9-11240/13 or the NAVFAC 11260/4.

The yard boss should initial the cards before the dispatcher files the cards in the Trouble Reports File. When a piece of equipment is scheduled for PM, the cards in the Trouble Reports File for that USN are forwarded with the piece of equipment.

CESE Assignments

Based on the recommendations of the company chief and the operations supervisor, the equipment officer approves the CESE assignments for a unit. These assignments ensure that personnel are provided the appropriate vehicles to accomplish their jobs.

Deployment CESE assignments should be generated by the transportation supervisor, assisted by the operations supervisor, during the home-port period. The CESE assignment list (fig. 1-8) is created by using the current deployed battalion's CESE assignments and your unit's last deployment CESE assignments. You must have an Equipment TAB A for your deployment site to use as a guide for the ECs and USN numbers. Assign the vehicles by their ECs. Some vehicles may not be available for dispatch after the Battalion Equipment Evaluation Program (BEEP). Assigning vehicles by EC provides plenty of flexibility for change. When the list is complete, be prepared to answer complaints from personnel not assigned a vehicle.

Category of Assignments

CESE assignments are divided into three dispatch categories: Class A, Class B, and Class C. Once you

have developed your equipment list, you must assign each vehicle one of the dispatch categories.

The Class A dispatch category is the full-time assignment of a vehicle to an individual. Class A continuing dispatch is only authorized by the Chief of Naval Operations (CNO).

The Class B dispatch category in the NCF normally is the once a week assignment of a vehicle that requires a DD 1970 (Trip Ticket). You know that most members of your unit desire to have vehicles on a Class B assignment. However, Class B vehicles must be continuously reviewed to ensure the vehicles are not used just for convenience, but are required to conduct official business. Second and Third NCB equipo recommends that Class B assigned vehicles should not exceed 5 percent of active assigned CESE.

The Class C dispatch category covers all CESE not under Class A or Class B. Class C assignments are made on an "as needed" basis. However, members and project crews are normally assigned the same CESE each day. CESE is turned in daily and maintained in the transportation pool. The transportation pool provides the maximum control over equipment and ensures efficient and economical vehicle use.

After you have divided the equipment assignment list into dispatch categories, submit the list through the chain of command for approval. The equipment officer approves the list. However, the equipment officer and the commanding officer both review the CESE assignment list before final approval.

During a deployment, evaluate odometer readings on assigned CESE to balance the mileage or hours. This process may require resubmitting an equipment assignment list through your chain of command.

Equipment Request

Equipment management is a daily battle because everyone thinks they should be assigned a vehicle. However, you must maintain an equipment pool that can provide replacements for unscheduled breakdowns, replacements for scheduled PMs, and daily transportation or equipment requests (fig. 1-9).

Developing a taxi service provides a method for moving people that reduces the need for individual assignment of vehicles. Have your taxi carry a radio, and use dispatch as the base station. This provides good communication and expedites service. A good

Class B Vehicle Assignments

<u>Assignment</u>	<u>Vehicle Type</u>	<u>EC #</u>	<u>USN</u>
1. C.O.	SEDAN		
2. S3	BLAZER	030731	
3. S3C	BLAZER	030731	
4. S4	1 1/4 T CARGO	036031	
5. A6	BLAZER	030731	
6. B6	BLAZER	030731	
7. C6	BLAZER	030731	

Class C Vehicle Assignments

<u>Assignment</u>	<u>Vehicle Type</u>	<u>EC #</u>	<u>USN</u>
1. S3S	BLAZER	030731	
2. S3QC/EA	1 1/4 T CARGO	036031	
	1 1/4 T CARGO	036031	
3. S4C/MLO	1 1/4 T CARGO	036031	
4. ADMIN/DUTY VEH	1 1/4 T CARGO	036031	
5. CMAA/POST OFFICE	1 1/4 T CARGO	036031	
6. GALLEY	15T STK TRK	064031	
7. MEDICAL	AMBULANCE	036131	
8. A4	1 1/4 T CARGO	036031	
9. MAINT FIELD CREW	MAINT TRK	072212	
10. A3	1 1/4 T CARGO	036031	
11. A32	1 1/4 T CARGO	036031	
12. A CO PROJECTS	15T STK TRK	064301	
13. A CO PROJECTS	15T STK TRK	064301	
14. ROAD MASTER	1 1/4 T CARGO	036031	
15. TAXI	1 1/4 T CARGO	036031	
16. LIVE STORAGE	1 1/4 T CARGO	036031	
17. OROTE POINT	15T STK TRK	064301	
18. DUTY BUS	BUS	006101	
19. B3	1 1/4 T CARGO	036031	
20. B4/CAMP MAINT	MAINT TRK	072212	
21. B32	1 1/4 T CARGO	036031	
22. B CO PROJECTS	15T STK TRK	064301	
23. B CO PROJECTS	15T STK TRK	064301	
24. C3	1 1/4 T CARGO	036031	
25. C32	1 1/4 T CARGO	036031	
26. C CO PROJECTS	15T STK TRK	064301	
27. C CO PROJECTS	15T STK TRK	064301	
28. C CO PROJECTS	15T STK TRK	064301	
29. C CO PROJECTS	15T STK TRK	064301	

Figure 1-8.—Sample deployment CESE assignments.

DATE: _____

VEHICLE/EQUIPMENT REQUEST

From: _____ COMPANY OPERATIONS CHIEF/DEPARTMENT CHIEF
To: ALFA COMPANY OPERATIONS

SUBJ: PROJECT # _____ LOCATION _____
PERSON TO CONTACT _____ PHONE # _____

TYPE OF EQUIPMENT	TIME AND DATE	OPERATOR REQUIRED	
		YES	NO

REMARKS:

COMPANY OPS CHIEF/DEPT CHIEF

From: ALFA CO OPS CHIEF
To: ALFA CO DISPATCHER
VIA: ALFA CO TRANSPORTATION SUPERVISOR _____
INITIALS

APPROVAL/DISAPPROVAL

ALFA CO OPS CHIEF

Figure 1-9.—Sample of a Vehicle/Equipment Request

taxi service reduces the number of members requesting an assigned vehicle.

Remember, one of your missions is to ensure the maximum service life of the equipment. This requires managing the number of CESE dispatched and controlling the mileage placed on CESE.

YARD BOSS

The yard boss is your equipment yard supervisor. This is the key position in a successful equipment management program. The yard boss enforces Operator Maintenance Procedures to reduce equipment breakdown.

The yard boss is responsible for the access, traffic flow, and condition of the equipment yard, the refueling facility, and supports the equipment washrack, the cycling and upkeep of equipment, and daily transportation operations.

Tool Kit

Each Battalion Table of Allowance (TOA) in the NCF contains a Tool Kit, Kit 80111, for the Yard Boss Program. This kit provides the minimum tools and equipment resources necessary to support operator maintenance. Operators requiring tools to perform maintenance should log out the tools through the yard boss.

Preventive Maintenance

The yard boss supports the Preventive Maintenance (PM) Program by ensuring the equipment is cleaned, lubricated, and processed through collateral equipment. The yard boss receives a NAVFAC 9-11240/13 (Hard Card) from the dispatcher who maintains a Hard Card log hook and issues a Hard Card number for tracking the maintenance of the equipment.

A recommended flow for PM Hard Cards is to have the yard boss submit two Hard Cards stamped PM and initialed by the collateral equipment custodian. The equipment, Hard Card, and cards from the Trouble Reports File for the USN are sent to the mechanic equipment inspector. The mechanic inspector approves or rejects the equipment, depending on cleanliness and lubrication. For equipment that is approved, the yard boss has the mechanic inspector sign receipt of the Hard Cards and retains one for the dispatch records.

Equipment Cycling

The yard boss must be aware of equipment in the yard that is not regularly used. Equipment must be exercised to protect it from deterioration. All parts of the equipment must be operated at the rated capacity for its intended use to constitute one complete performance. Remember, starting and running the engine cycles the engine but not the equipment. The yard boss must maintain a cycle log documenting date, USN, duration equipment cycled, and any deficiencies. Equipment must be maintained in a standby status and cycled on a weekly basis.

Washing of CESE

Part of the preventive maintenance program is the daily cleaning of CESE that allows the detection and prevention of major problems. Dirt and grime can make an engine run at excessive temperatures, increase fuel consumption, ruin hydraulic cylinders, corrode wiring, and destroy components. Additionally, dirt and grime can add over 1,000 pounds of excess weight to an earthmover, clog radiators and possibly bring CESE to a grinding halt. Therefore, it is very important to REMEMBER that dirt and grime cripples CESE performance and increases operating costs.

The use of a high-pressure washer or steam is effective means for removing the crusty, gritty buildup of dirt, grease, and grime from transmissions, track and roller assemblies, engine blocks, and drive trains. The cleaning of equipment provides the following results: extended equipment life; enhanced efficiency of mechanics when they perform equipment inspections and repairs and increased efficiency of operators when they perform pre and post operational checks.

Thorough cleaning of equipment cannot be accomplished with water alone. To provide an effective wash program, the yard boss must maintain a supply of soap, brushes, rags, buckets, serviceable hoses, and a trash can at the washrack. Additionally, when manning allows, the yard boss should assign a washrack attendant to assist in maintaining wash rack operations.

PM-to-Interim Repair Ratio

The PM-to-interim repair ratio is the number of scheduled preventive maintenance actions compared to unscheduled maintenance actions (interim repairs).

The COMSECOND/COMTHIRDNCB equipo goal for PM-to-interim repair ratio is three scheduled PM inspections to each interim repair. The yard boss provides the first step toward meeting this goal by enforcing **Operator Maintenance**. Every operator must keep assigned vehicles clean, safe, and in serviceable condition. Daily, operators should inspect the following: fuel, oil, water, hydraulic fluids, battery levels, tires, lug nuts, lights, drive belts, mounted equipment, and exterior or interior damage. Operators must usc their sense of smell, sight, and feel while operating equipment and note defects on the Hard Cards.

An ideal Equipment Managment Program requires the yard boss review all Hard Cards and NAVFAC 11260/4 forms for any deficiency. From this review the yard boss determines if a repair should be performed by the operator, evaluated by the mechanic inspector, or to place the cards and forms in the Trouble Reports File.

Sitting behind a desk is not the only job of a transportation supervisor. Be active! Schedule your work to ensure you are out in the yard during prestart and post operations to reinforce the Yard Boss Program. As the pool supervisor, you should review what CESE the yard boss is sending to the shop for repairs that can impact the PM-to-repair ratio. Discuss priority equipment problems with the operation and maintenance supervisors. Remember, adding fluids, tightening belts, changing light bulbs, and lubricating are all operator maintenance. Daily communication between the pool supervisor, yard boss, and dispatcher concerning the condition and availability of equipment is vital. As the transportation supervisor, you must also communicate daily with the operations and maintenance supervisors on the conditions of the transportation pool.

Equipment Availability

Equipment availuability is the percentage of time the equipment is available for dispatch compared to downtime. Equipment downtime is figured on a 24-hour, 7-day-week basis. Ninety percent equipment availability is considered excellent, 85 percent is good, and 75 percent and below is poor.

The maintenance supervisor monitors equipment availability. Overworked or abused equipment,

inadequate parts support, or shortage of mechanics result in poor equipment availability.

A strong Yard Boss Program is the key to increased equipment availability and a decrease in equipment downtime.

COLLATERAL EQUIPAGE

The proper management of collateral equipage can enhance a unit's Equipment Management Program. However, when this area is neglected, a high cost collateral equipage turnover can hinder any effective Equipment Management Program.

Maintenance supervisors are very concerned with collateral equipage operations. Collateral equipment accountability is part of contingency readiness, and the ordering of collateral equipment is the same as ordering repair parts that are approved by the maintenance supervisor.

As the transportation supervisor, you should make rounds of the collateral equipage area. Collateral equipage is divided into two basic types: component collateral equipage and tactical collateral equipage.

Component Collateral Equipage

Component collateral equipage consists of items, such as hoses for pumps and bits for the earth auger. These items are normally procured on the same contract as the basic machine. The history jacket should contain a list of the amount and types of component collateral equipage.

Tactical Collateral Equipage

Tactical collateral equipage consists of items common to the equipment, such as top canvas and tarpaulin, bows and side racks, spare tire and rim, jack and lug wrench, and chains with hooks and binders.

COLLATERAL EQUIPAGE CUSTODIAN

The collateral equipage custodian is a seasoned operator who possesses an in-depth knowledge of collateral equip age terms, procedures, and equipment. The collateral equipage custodian maintains a Collateral Custody Record Card,

(ECC)	(USN)	(FSN/Part No.)	(Noun Name)	(Allowance)	(U/I)	(AIL No. - Page-Line)	(Unit price)
CBPAC/CBLANT 60 FORM						LOCATION BIN #	
TRANSACTION RECORD						I acknowledge custody of this item in the quantity indicated.	INVENTORY RECORD
DATE	DOCUMENT NO	REC'D FR: W/EXPEND TO	REC'D	EXPLND	BALANCE	DATE	QTY
						BY	
						DATE	QTY
						BY	
						DATE	QTY
						BY	
						DATE	QTY
						BY	
						DATE	QTY
						BY	
						DATE	QTY
						BY	
						DATE	QTY
						BY	
						DATE	QTY
						BY	

Figure 1-10.—Collateral Custody Card, COMSECOND/COMTHIRDNCB 60 Form.

1 REQ DATE 8027	2 DEPT NO	3 URGY B	4 RDD 8057	5 LOCATION MU2	6 SIM <input type="checkbox"/>	6 NON-SIM <input type="checkbox"/>	7 ISSUE DATE	A REON QTY.	B REON NO							
8 NOUN NAME OR REF SYM L A T C H		9 FPR <input type="checkbox"/>	10 APL/AEL/CID 9 5 0 2 2 4 7 3 4		11 AMT QTY	12 MIS <input type="checkbox"/>	12 N/C <input checked="" type="checkbox"/>	C OBL AMT	D POSTED							
13 UIC R 5 5 0 4		14 WC A A 0 0		15 JSN 2 0 8 9	17 EQUIP COSAL SUPPT'D YES <input checked="" type="checkbox"/> NO <input type="checkbox"/>		E URG <input type="checkbox"/>	MART <input type="checkbox"/>	OPTAR LOG S/R (ISSUE)							
18 SC -	19 COG 9 Z	20 MCC 5 3 3 0	21 FSC 0 0 2 9 1 2 8 3 4		22 STOCK NUMBER N I I N	23 S/M/C	24 U/I E A	25 QUANTITY 0 0 0 1	26 UNIT PRICE 1 5 0 0	27 EXTENDED PRICE	28 FUND					
29 REMARKS USN 95-21179 PMG 8								30 APPROVED BY								
								31 RECEIVED BY								
DOC IDENT	ATG IDENT	M & S	SVC	UIC	JUL DATE	SERIAL	O E M	S V C	SUPPL ADDRESS	S I G	FUND	DIST	PROJ	PRI	ROD	ADV

SINGLE LINE ITEM CONSUMPTION/REQUISITION DOCUMENT (MANUAL)
NAVSUP FORM 1250-1 (7 PT) (REV 12/78) S/N 0108-LF-501-2506

Figure 1-11.—Single-Line Item Consumption/Management Document (Manual), NAVSUP Form 1250-1.

COMSECOND/COMTHIRDNCB 60 Form (fig. 1- 10), for each line item of equipage for each unit of CESE. The equipage custodian enters all outstanding requisitions, receipts, issues, locations, losses, and annotates the allowance of a particular line item of equipage for each CESE on the CB 60 form.

The equipage custodian maintains the CB 60 forms in folders for each USN-numbered CESE. The CB 60 forms are pulled on the PM date to perform an

inventory of mounted or stored collateral equipage for each USN-numbered CESE entering the shop. The equipage custodian prepares a NAVSUP Form 1250-1 (fig. 1-11) or a 1250-2 (fig. 1-12) for lost, damaged, or deteriorated collateral equipment. Outstanding requisitions, amount of gear on hand, and the date inventoried are all on the CB 60 form. The inventory procedures are accountable man-hours on the Equipment Repair Order.

NON-NSN REQUISITION (4491)																																																																																																			
A REQ DATE 8027					B DEPT NO					C URGY B					D RQD 8057					E LOCATION NU2					F SIM <input type="checkbox"/> SIM <input type="checkbox"/> NON SIM					G ISSUE DATE					H REQ QTY					I REQ NO																																																											
J NOUN NAME OR REF SYM LATCH										K FPR					L APL/ALCID 950224734										M REV QTY					N <input type="checkbox"/> NIS <input checked="" type="checkbox"/> NIS					O OBL AMT					P POSTED																																																											
JOB CONTROL NUMBER										Q UIC R : 55504					S JSN AAOO					T EIC 2089					U EQUIP LOCAL SUPP'D <input checked="" type="checkbox"/> YES <input type="checkbox"/> NO					V URG <input type="checkbox"/> URG <input type="checkbox"/> MART					W OPTAR LOG					X S/R (ISSUE)																																																											
DOCUMENT IDENTIFIER					ROUTING IDENTIFIER					NAVY ITEM CONTROL NUMBER (NICN) OR P-NICN										UNIT OF ISSUE					QUANTITY					DOCUMENT NUMBER																																																																					
1	2	3	4	5	6	7	8	9	10	11	12	13	14	15	16	17	18	19	20	21	22	23	24	25	26	27	28	29	30	31	32	33	34	35	36	37	38	39	40	41	42	43	44	45	46	47	48	49	50	51	52	53	54	55	56	57	58	59	60	61	62	63	64	65	66	67	68	69	70	71	72	73	74	75	76	77	78	79	80	81	82	83	84	85	86	87	88	89	90	91	92	93	94	95	96	97	98	99	00
										EA										00001																																																																															
AA SUPPLEMENTARY ADDRESS										BB FUND CODE					CC DISTRI BUTION CODE					DD PRODUCT CODE					EE QUANTITY					FF REQUIRED DELIVERY DATE					GG BLANK					HH SUBJECT CODE FOR USE BY SUPPLY SOURCE ONLY																																																											
AA MANUFACTURER'S CODE AND PART NO. 83179										BB MANUFACTURER'S NAME, ADDRESS AND POINT OF CONTACT (POC) Joy Manufacturing Co., Air Power Group 900 Woodland Avenue Michigan City, IN 46360-5672 Phone: (412) 562-4711										CC SHIP'S POC					DD NAME					EE RATE					FF DIVISION					GG PHONE ()																																																											
DD TECH MANUAL NO./BLUEPRINT NO. 7610 LL L7A 6251										EE END ITEM APPLICATION										FF MANUFACTURER'S CATALOG IDENTIFICATION Joy Portable Air Compressor MODD125S					GG CATALOG DATE					HH TECHNICAL ORDER NO.																																																																					
II DESCRIPTION OF ITEM REQUESTED / COMPLETE NAMEPLATE DATA FROM EXISTING UNIT ILLUSTRATION PAGE 5-4, FIGURE 2 ITEM 15 DESCRIPTION PAGE 5-15 ITEM 15										JJ MAKE JOY					KK MODEL NO. D125S					LL SERIES 1977					MM SERIAL NO. 135186					NN COLOR					OO SIZE																																																																
KK SOURCE OF SUPPLY (incl phone and POC if avail)																																																																																																			
LL ACCOUNTING DATA																																																																																																			
MM REQUISITIONER (Clear text name and address)																				NN APPROVED BY: (Supply/Contracting/Ordering Officer) NAME _____ RANK _____ SIGNATURE _____																																																																															

Figure 1-12.—Non-NSN Requisition, NAVSUP Form 1250-2.

The operators of Class B assigned CESE signs the CB 60 form assuming full custody of mounted collateral gear. CB 60 forms for Class C mounted collateral gear on CESE are signed by the yard boss. The mounted collateral gear should be annotated on the daily (rip ticket, and custody is assumed by the operator who signs the trip ticket, or the collateral equipage can be issued and returned to collateral each time the unit of CESE is dispatched.

ATTACHMENT CUSTODIAN

Attachments are accessories to construction equipment that enable the basic equipment to perform its function or adds versatility. Attachments are stored on handstands to keep the items out of sand, mud, and water. Hydraulic lines and fittings are sealed for protection from dirt and moisture.

Attachment accessories, such as bucket teeth, sprockets, drum lagging, and wedges, are placed in boxes or on pallets and marked for the appropriate equipment. Wire rope, sheaves, and bolt threads are lubricated. Nuts and bolts are stored in their respective holes on the attachments when possible. Exposed machined surfaces and open parts are preserved to prevent oxidation and damage. Storage is maintained to ensure attachments belonging to one USN number are stored together.

The attachment custodian maintains a card file and log that provides an accurate inventory of receipts and issues of attachments, when the attachments were last lubricated, and any damage incurred from one operation to another. In addition, the custodian is responsible for

the segregated storage of all attachments and their associated accessories.

The Attachments Status Board (fig. 1-13) is maintained in the dispatcher's office by the attachment custodian. The Attachments Status Board reflects the attachment code, NAVFAC identification number, abbreviated description, the USN number of the equipment to which the attachment is assigned, the PM group (same as the equipment the attachment is assigned), and location and remarks. The collateral equipage custodian usually performs the duties of the attachment custodian.

FUEL OPERATIONS

The transportation pool manages all fuel operations. The Equipment Operator in charge of fuel operations must be mature, independent, and reliable. The abilities to communicate and to maintain logs are also required. A poor fuel program results in needless downtime of equipment and delays in production.

The fuel truck driver reviews the Equipment Status Board to determine the location of all CESE. The driver learns the fuel requirements and function of all equipment used on construction projects by communicating with the project crew leaders, the assigned Equipment Operator, and the transportation supervisor.

The fuel truck driver must be knowledgeable of all CESE. The driver must avoid fueling with the wrong fuel or filling hydraulic or cooling systems with fuel. Maintenance and transportation super-visors have fuel tanks stenciled with the words *MOGAS* or *DIESEL* to avoid this problem.

ATTACHMENTS STATUS BOARD					
<u>Code</u>	<u>NAVFAC I.D. NO.</u>	<u>Description</u>	<u>USN No. Assigned</u>	<u>PMG</u>	<u>Location and Remarks</u>
A01000	L175B-BH-5	Backhoe	45-01799	17	Attachment Pad
A02500	255-BB-56	Boom Butt	42-01778	9	42-01778
A03000	32-BE-72	Boom Ext	82-03173	14	Attachment Pad

Figure 1-13.—Attachments Status Board.

The fuel truck driver must maintain accurate records of fuel issues, by equipment USN number, in a log. The driver also maintains records of bulk issues of fuel for the tank truck and yard fuel pumps. The driver must ensure fuel availability for contingency readiness, daily transportation, and construction operations.

The fuel truck driver maintains standards for the fuel tanker according to COMSECOND/COMTHIRD-NCBINST 11200.1 Series. Vehicles used for bulk transport of gasoline, fuel, oil, or other flammable liquids are marked on both sides and the rear with the word FLAMMABLE in 6-inch black letters. The words NO SMOKING WITHIN 50 FEET is marked in 3-inch black letters and numerals. A removable plate painted black with yellow letters to designate the liquid being transported is inserted in a 8-inch by 36-inch bracket that is bolted on each side of the tanker. The plate should have MOGAS painted on one side and DIESEL painted on the opposite side in 6-inch letters.

The fuel truck driver must maintain the fire extinguisher on the tanker truck. Second and Third NCB equipo recommends the guidelines set forth in the U.S. Army Corps of Engineers, Safety and Health Requirements Manual, EM 385-1-1. At least one portable fire extinguisher not less than 20-B:C units (20 = lbs, B = petroleum, C = electrical) shall be provided on all tank trucks or other vehicles used for transporting or dispensing flammable or combustible liquids. The fire extinguisher must be securely mounted on the vehicle, properly filled, and located to ensure it is readily accessible for use.

The fuel truck driver must have knowledge of environmental pollution. Fueling operations must always be under controlled conditions and closely monitored. Fuel spillage can be disastrous.

TRACTOR-TRAILER OPERATIONS

Tractor-trailer operations are managed by the transportation supervisor. The hauling of equipment for the Preventive Maintenance Program and the hauling of construction supplies generates thousands of miles of tractor-trailer operations during a deployment.

The tractor-trailer drivers must be mature, reliable, and experienced. The hauling of oversized, heavy equipment is no job for inexperienced operators. For valuable training and future replacements, you should assign your inexperienced operators with the experienced operators.

During the home-port period the operational pace slows and your crews lose an edge of professionalism. You must stay on top of all operations to ensure that oversized, heavy loads are handled by your best operators to avoid any mishaps. You must emphasize to your crews that when the

tractor-trailers are on the open road they represent the U.S. Navy and the Seabees to the public.

As the transportation supervisor, you ensure your tractor-trailer drivers adhere to the standards and procedures set forth in the Commercial Driver License (CDL) Handbook for the state or states you operate in. Height and width limitations are set by each state, and you must obtain state permits to haul oversized loads. On deployment, you must obtain all rules and regulations for tractor-trailer operations from the local department of motor vehicles and base security. With the materials you obtain, develop a turnover folder for the next incoming battalion.

COMSECOND/COMTHIRDNCBINST 11200.1 Series authorizes the use of operator nameplates. Nameplates are constructed of wood 3 1/2 inches high by 18 inches long; the wood is painted green with 2-inch high lettering painted glossy yellow. To increase pride of ownership and personal care, you should assign each tractor-trailer driver a tractor-truck with their nameplates centered on the front grille of the vehicle.

Chains and binders are collateral equipment for low-boy trailers. The chains and binders are maintained and issued by the collateral equipment custodian. Depending on the amount of tractor-trailer operations, you may require all chains and binders checked out and returned on a daily basis. Make the drivers accountable and responsible for issued collateral gear. Leaving chains and binders unused in the storage compartment or on top of the trailer results in rust, excessive deterioration, or theft.

Cargo and equipment securing procedures are set forth in the Federal Motor Carrier Safety Regulation Pocketbook. The aggregate static breaking strength of tie-down assemblies used to secure an article must be at least 1 1/2 times the weight of that article. Chains used as tie-down assemblies must conform to the requirements of the National Association of Chain Manufacturer's Welded and Weldless Chain Specifications applicable to all types of chain. Binders used in conjunction with a tie-down assembly must be equal to or greater than the minimum breaking strength of the tie-down assembly.

The load on every vehicle must be distributed, chocked, tied down, or secured according to U.S. Army Corp of Engineers, Safety and Health Requirements Manual, EM 385-1-1. It takes much less time to tie down a load than it takes to report the reason a load fell off a trailer. After delivery of cargo, the driver should broom off all debris from the trailer to prevent possible damage to other vehicles or injury to pedestrians during the return trip. The operator is responsible for the safe operation of the tractor-trailer and the securing of cargo.

BUS SERVICE

To reduce the amount of CESE on the road, you can deliver crews to jobsites by an established bus service. Vehicle breakdowns, scheduled PMs, and new construction tasking are times when a bus service is the best answer for transporting crews to jobsites. Jobsites having some type of communication should be considered for bus service. Remember, remote jobsites require a safety vehicle. When bus service is used, construction materials can be delivered to the jobsite by the tractor-trailer crew. Crew vehicles must be monitored to ensure proper use. They are not to be just a convenience for the crew leader.

The transportation supervisor manages the liberty bus service. Assign mature, reliable equipment operators for this duty. During the predeployment visit, request the on-site deployed unit's liberty bus policy and schedule. This policy and schedule provides you and the operations supervisor information to use to generate a liberty bus policy for your unit. The equipment officer, company chief, and maintenance supervisor evaluate and preapprove the policy. The commanding officer has the final approval and must sign the policy into effect. The bus service is for the troops; ensure you establish a bus route that accommodates their needs.

MAINTENANCE FIELD CREW OPERATIONS

Dispatchers are the hub of communications for trouble calls for CESE in the field. The success of a deployment from an equipment maintenance and project completion standpoint can be traced to the availability of equipment due to the field maintenance crew's ability to perform adequate and timely repairs in the field. The field maintenance crew reduces the equipment shop work load by repairing CESE in the field. The dispatchers maintain a log to track the flow of field repairs and inform the heavy shop supervisor of any trouble calls. The equipment heavy shop supervisor controls the field maintenance crew operations. The maintenance held crew must daily inform the dispatchers of the status of repairs made to CESE. The extent of damage on the CESE might require shop repairs. The dispatcher should schedule the hauling of the CESE to the shop and schedule possible CESE replacement. The dispatcher must inform you of all actions and update the field crew repair log.

EQUIPMENT MAINTENANCE PROGRAM

At all times, the goal of the Equipment Maintenance Program is to keep all CESE in a safe and serviceable condition at a reasonable cost and to detect minor deficiencies before they develop into costly repairs.

MAINTENANCE SUPERVISOR

The maintenance supervisor is normally the senior mechanic responsible for the maintenance program for all assigned CESE. The maintenance supervisor supervises the inspectors, shop supervisors, preventive maintenance and cost control clerks, technical librarian, and the part's expeditor. Additionally, this position is responsible for enforcing all established maintenance policies, approving all repair actions and requisitions, controlling all CESE transfers and disposal, supervising the Preventive Maintenance Program, and controlling all mechanics, shop tools, and kits.

The maintenance supervisor coordinates closely with the operations supervisor on all equipment requirements, equipment abuse, and reoccurring equipment breakdowns.

Inspector

The equipment inspector is a knowledgeable and proficient senior Construction Mechanic, preferably a CM1, capable of readily determining the nature of the necessary repairs on any piece of equipment. The inspector exercises independent judgment as to whether the equipment requires immediate attention or can be delayed until the scheduled PM. When repairs are required, the inspector must have the ability to describe each repair action clearly on the Equipment Repair Order (ERO), NAVFAC 11200/41. After performing a final inspection and determining that repairs have been satisfactorily completed and the equipment is ready for full service, the equipment inspector should take the ERO and the equipment to dispatch for customer approval and the signing of Block 77 of the ERO. The ERO is then returned to cost control for final closing.

Preventive Maintenance (PM)/Cost Control Clerk(s)

Working directly for the maintenance supervisor, the PM/cost control clerk divides all CESE into preventive maintenance (PM) groups, prepares the PM schedule, and maintains the PM Record Card, NAVFAC 11240/6 (fig. 1-14), with the preventive

ASSIGNED TO NMCB _____			PHONE	TYPE OF ASSIGNMENT _____	EQUIP CODE 423001	JOB ORDER NO. _____	PM GROUP 13			
NAME BUCYRUS ERIE			MODEL 30B	TYPE D	YEAR 82	EST. ANNUAL MI/HR	USN REG. NO. 42-03317			
TYPE PM	DATE	CUMULATIVE MILEAGE OR HRS. OPN.	MILES (OR HRS) SINCE LAST PM	MILES (OR HRS) REPORTED FOR 6 MO. PERIOD	TYPE PM	DATE	CUMULATIVE MILEAGE OR HRS. OPN.	MILES (OR HR) SINCE LAST PM	MILES (OR HR) REPORTED FOR 6 MO. PERIOD	
LAST A	2-4-88	1945	} ENTRIES TRANSLATED FROM PRIOR RECORD	[REDACTED]						
LAST B	6-5-88	2259								
LAST C	4-1-88	2060								
07	6-1-88	2100								
01	7-26-88	2156								
01	9-21-88	2340								
02	11-16-88	2510	O/C,F/C,FF/C,HF,C							

VEHICLE/CONSTRUCTION EQUIPMENT PM RECORD NAVFAC 11240/6 (2 75) SUPERSEDES NAVDOCKS 1949

TYPE PM	DATE	CUMULATIVE MILEAGE OR HRS. OPN.	MILES (OR HRS) SINCE LAST PM	MILES (OR HRS) REPORTED FOR 6 MO. PERIOD	TYPE PM	DATE	CUMULATIVE MILEAGE OR HRS. OPN.	MILES (OR HR) SINCE LAST PM	MILES (OR HR) REPORTED FOR 6 MO. PERIOD
					A14000		FAIRLEAD	1	
					A04000		BOOM TIP	1	
					A03500		BOOM JIB	1	
					A02500		BOOM BUTT	1	
					A11500		CRANE HOOK	1	
					A03000		BOOM EXT	3	
					A23500		TAG LINE	1	

NAVFAC 11240/6 (2-75) BACK

*U.S. GOVERNMENT PRINTING OFFICE 1980-603-189/6831 2-1

Figure 1-14.—Sample of Vehicle/Construction Equipment PM Record, NAVFAC 11240/6.

maintenance history for each vehicle. The PM/cost control clerk(s) controls EROs, maintains the ERO Log (fig. 1-15), the equipment history jackets, and the maintenance office Equipment Status Boards. Additionally, the PM/cost control clerk(s) summarizes the total repair cost, labor expended, and makes entries on the ERO. The dispatcher communicates with the PM/cost control clerk when updating the

Equipment Status Boards and the equipment PM schedule.

An equipment history jacket is maintained for each USN-numbered item of CESE. The jacket contains pertinent descriptive data and the maintenance history for the vehicle. The descriptive data includes the appropriate DOD Property Record, DD Form 1342 (fig. 1-16), and Equipment

ERO NUMBER	CODE	USN NUMBER	TYPE ERO				DATE IN	DATE OUT	REMARKS
			INT	A	B	C			
AA00 0001	252021	25-01286	X				11/2/2	11/8/2	
AA00 0002	030701	97-23465		X			11/2/2	11/2/2	
—	—	—	—	—	—	—	—	—	—
—	—	—	—	—	—	—	—	—	—
—	—	—	—	—	—	—	—	—	—
AA00 0013	485011	48-00123	X		X		11/28/2	12/12/2	D/L 12/1/2

ERO NUMBER - Eight-digit number. The first four digits of the ERO number will be two Alpha characters and two numeric such as AA00. The second group will be all numeric and will run continuously from 0001 through 9999 with no regard to end of fiscal year.

CODE - Self -explanatory. (Six Digit)

USN NUMBER - Self explanatory.

TYPE ERO - Type maintenance performed: interim repair A, B, or C-PM.

DATE IN (SHOP) - Date ERO forwarded to inspector.

DATE OUT (SHOP) - Date ERO returned. Work completed.

REMARKS - Date deadlined etc.

Figure 1-15.—Equipment Repair Order Log Sheet.

DOD PROPERTY RECORD			1. <input type="checkbox"/> ACTIVE <input type="checkbox"/> INITIAL <input type="checkbox"/> IDLE <input checked="" type="checkbox"/> CHANGE		2. JULIAN DATE 6088		3. I.D./GOVERNMENT TAG NO. 94-04803		Form Approved OMB No. 22-R0209			
SECTION I - INVENTORY RECORD												
4. COMMODITY CODE		5. STOCK NUMBER 2320005401428		6. ACQUISITION COST \$3,805.00		7. TYPE CODE 4	8. YR OF MFG 78	9. POWER CODE 4	10. STATUS CODE	11. SVC CODE	12. COMMAND CODE	13. ADM OFFICE CODE V55460
14. NAME OF MANUFACTURER CHRYSLER CORPORATION DODGE DIVISION				15. MFR'S CODE 86403		16. MANUFACTURER'S MODEL NO. 6 D100			17. MANUFACTURER'S SERIAL NO. D14AB8S296712			
18. LENGTH 194"	19. WIDTH 80"	20. HEIGHT 73"	21. WEIGHT 3576	22. CERTIFICATE OF NON-AVAILABILITY NUMBER 249-78-MP-GW203			23. PEP NO.	24. ARD	25. CONTRACT NUMBER GS-005-78418			
26. DESCRIPTION AND CAPACITY TRUCK CARGO PICKUP 4X2 GED 4800GVW <div style="text-align:right;">CONTINUED ON REVERSE SIDE <input type="checkbox"/> YES <input type="checkbox"/> NO</div>												
SECTION II - INSPECTION RECORD												
27. ELECTRICAL CHARACTERISTICS												
QUANTITY	HORSEPOWER	VOLTS	PHASE	CYCLE	AC	DC	SPEED	TYPE AND FRAME NUMBER				
28. PRESENT LOCATION 20TH NCR GULFPORT MS 39501-5002								28a. DIPEC CONTROL NO.				
								29. POSSESSOR CODE V55460				
27. ELECTRICAL CHARACTERISTICS												
28. PRESENT LOCATION												
29. POSSESSOR CODE												
SECTION III - REMARKS												
30. CAN ITEM BE STORED AND MAINTAINED ON SITE FOR AT LEAST 12 MONTHS? YES NO												
31. HAS ITEM BEEN REBUILT/OVERHAULED? IF SO, WHEN? DATE												
32. HAS ITEM BEEN MODIFIED FROM ORIGINAL CONFIGURATION? IF SO, EXPLAIN UNDER REMARKS BELOW												
33. WAS ITEM INSPECTED UNDER POWER? IF NOT EXPLAIN UNDER REMARKS BELOW												
34. ARE MAINTENANCE COSTS NORMAL? IF NOT, EXPLAIN UNDER REMARKS BELOW												
35. ARE SAFETY DEVICES ADEQUATE AND SATISFACTORY? IF NOT, EXPLAIN UNDER REMARKS BELOW												
36. ARE INSTALLATION INSTRUCTIONS AVAILABLE FOR TRANSFER?												
37. ARE OPERATING INSTRUCTIONS AVAILABLE FOR TRANSFER?												
38. WAS ITEM LAST USED ON A FINISHING OPERATION?												
39. WILL ADJUSTMENTS OR CALIBRATION CORRECT DEFICIENCIES?												
40. IS ITEM SEPARABLE WITHOUT DAMAGE TO COMPONENTS? IF NOT, GIVE THEIR REPLACEMENT COST \$												
41. IS ITEM IN OPERABLE CONDITION?												
42. MUST ITEM BE REPAIRED/REBUILT/OVERHAULED TO PERFORM ALL FUNCTIONS? \$												
43. DO QC RECORDS INDICATE SATISFACTORY PERFORMANCE? IF NO, EXPLAIN UNDER REMARKS BELOW												
44. ARE MANUALLY OPERATED MECHANISMS IN WORKING ORDER? IF NO, DESCRIBE UNDER REMARKS BELOW												
45. ARE SCALES, DIALS, AND GAUGES WORKING AND READABLE? IF NO, DESCRIBE UNDER REMARKS BELOW												
46. ARE HYDRAULIC PUMPS, VALVES, AND FITTINGS OPERATING PROPERLY? IF NO, DESCRIBE UNDER REMARKS BELOW												
47. ARE ELECTRONIC SYSTEMS AND CONTROLS OPERATING PROPERLY? IF NO, DESCRIBE UNDER REMARKS BELOW												
48. HOW MANY HOURS WAS ITEM USED BY CURRENT POSSESSOR?												
49. EXPLAIN UNDER REMARKS LAST USE OF EQUIPMENT DESCRIBED IN ITEM 26 ABOVE												
50. ESTIMATED COST FOR PACKING, CRATING, INSURING \$												
51. INDICATE DATE ITEM WILL BE AVAILABLE FOR REDISTRIBUTION.												
52. CONDITION CODE A-5												
53. OPERATING TEST CODE.												
34. REMARKS 1. TC-6 2. SC-T 3. ECC 031301 <div style="text-align:right;">REMARKS CONTINUED ON REVERSE SIDE <input type="checkbox"/> YES <input type="checkbox"/> NO</div>												
SECTION IV - DISPOSITION RECORD												
55. CONSIGNEE (NAME AND ADDRESS, INCLUDING ZIP CODE)						56. TYPE OF DISPOSITION <input type="checkbox"/> DONATION <input type="checkbox"/> DESTRUCTION <input type="checkbox"/> SALE <input type="checkbox"/> ABANDONMENT			56a. DATE OF DISPOSITION AND PROCEEDS IF SOLD			
SECTION V - VALIDATION RECORD												
57. VALIDATION (TYPED NAME(S) AND SIGNATURE(S)) CMI DALLAS J. MeGIE												

Figure 1-16.—DoD Property Record, DD Form 1342

EQUIPMENT ATTACHMENT REGISTRATION RECORD NAVFAC 6-11200/45 (1-70) S/H 0105.LF.002.5405										22. NAVFAC ID NO. T20-CL-1002	
1. ATTACHMENT CODE A09000		2. TYPE ATTACHMENT CABLE LAYER				3. MODEL NO. 4067		4. SERIAL NUMBER 8720			
5. LENGTH (Inches) 6"		6. WIDTH (Inches) 10"		7. HEIGHT (Inches) 52"		8. CUBES (Cubic Feet)		9. SIZE/CAPACITY 36" 1" cable			
10. MANUFACTURER (Name and Address) American Tractor Equipment Corp.								11. WEIGHT (Lb) 450		12. FSM ---	
13. SHORT DESCRIPTION PECULIAR TO: ECC 4850 TRACTOR CRAWLER				14. MAKE INT		15. MODEL TD20		16. YEAR 66-67			
17. ACCESSORIES Three fairlead assemblies											
18. ASSIGNED TO 48-00000				19. DATE RECEIVED 4/26/88		20. ACQUISITION COST \$ 600.00		21. JULIAN DATE REGISTERED 9 1 1 6		22. NAVFAC ID NO. T20-CL-1002	

Figure 1-17.—Equipment Attachment Registration Record, NAVFAC 6-11200/45.

Attachment Registration Record, NAVFAC 6-11200/45 (fig. 1-17), when applicable. The history jacket also includes the completed PM record cards and the blue copies of completed EROs. EROs relating to acceptance checks, PMs, accident reports, speedometer or hour meter replacement, and all repair records are retained in the history jacket for the life of the equipment. When a vehicle is transferred, the PM record card is removed from the PM group file and returned to the history jacket. The jacket is hand carried or forwarded by certified mail to the receiving custodian. The history jacket should accompany a vehicle when it is transferred to a property disposal office.

Direct Turnover Clerk

The direct turnover (DTO) clerk maintains the maintenance shop's repair parts status and accountability records and is the liaison between the supply office and the shop. All requisitions for not in stock (NIS) and not carried (NC) materials must pass through the DTO clerk who maintains the DTO Log (fig. 1-18). The DTO clerk receives DTO parts and stores them by USN in PM groups and notifies the cost control clerk of parts received.

The DTO room is a secured area large enough to contain forty 12-inch by 12-inch cubes labeled with a

DIRECT TURNOVER LOG (DTO)													
DATE	DEPT.	PMG	USN NUMBER	NSN-P/N	ITEM	UNIT PRICE	QTY	PRI	NC/NIS	REQ. NO.	FOLLOW-UP	REC'D	ISSUED & INITIAL

Figure 1-18.—Direct Turnover (DTO) Log.

PM group. When DTO parts are received, they must be placed in the cube that corresponds to the PM group of the equipment requiring the parts.

Technical Librarian

Technical librarians are responsible for the prepacked library consisting of operational, maintenance, and part's manuals. They establish and enforce check-out procedures for manuals and initiate parts requisitions on NAVSUP Form 1250s. The task of researching and preparing the 1250s is normally handled by the technical librarian to free the floor mechanics to perform maintenance functions.

MAINTENANCE LEVELS

The CESE Maintenance System of the NCF and SOU has three categories of maintenance. These three categories are (1) organizational, (2) intermediate, and (3) depot.

Organizational Maintenance

Organizational maintenance is divided into two classifications: operator maintenance and preventive maintenance. Operator maintenance is that which every operator is required to perform to maintain the equipment in a clean, safe, and serviceable condition. It includes the daily inspections, lubrications, and adjustments necessary to ensure early detection of equipment malfunctions. The prime objective of preventive maintenance is to maximize equipment availability and minimize repair costs. Preventive maintenance consists of safety and serviceability inspections, lubrication, minor services, and adjustments beyond those in operator maintenance. Operators should participate in this work unless specifically directed otherwise.

Intermediate Maintenance

Intermediate maintenance provides a higher degree of skill than organizational maintenance. The extent of intermediate maintenance is the removal, replacement, repair, alteration, calibration, modification, and the rebuild and overhaul of individual assemblies, subassemblies, and components. Only essential repairs are accomplished to ensure safe and serviceable equipment. Prior approval is required on equipment requiring extensive repairs or numerous assemblies that are rebuilt.

Depot Maintenance

Depot maintenance is performed on equipment requiring major overhaul or comprehensive restoration that returns CESE to a like-new condition. Most NCF depot maintenance is performed by the Construction Equipment Department (CED) at both Port Hueneme, California, and Gulfport, Mississippi.

Maintenance Scheduling

The standard interval between PM service inspections for NCF equipment is 40 working days. This interval is established by grouping all assigned equipment into 40 separate PM groups (fig. 1-19). The equipment is distributed evenly throughout the PM groups, so only a minimum number of similar types of equipment are out of service at the same time. For reserve units, the standard PM interval is 90 calendar days, and the equipment is assigned to one of six PM groups.

The maintenance supervisor is responsible for determining when the PM interval for an item of equipment should be reduced. The time interval can be reduced by assigning specific items of equipment to more than one group or by reducing the total number of groups. The interval between PM service inspections for active CESE should never extend beyond the maintenance scheduling standards. Continuity of the PM schedule is maintained by transferring the schedule from a relieved unit to the relieving unit.

TYPE A (01) INSPECTION.— Type A inspections are given at intervals of 40 working days, using the appropriate PM Service and Inspection Guide set forth in the COMSECOND/COMTHIRD-NCBINST 11200.1 Series. Type A inspections are given at 90 calendar days for the reserve NCBs. Type A inspections are performed on each PM scheduled date until the vehicle qualifies for a Type B inspection.

TYPE B (02) INSPECTION.— To prevent a unit of CESE from being over inspected or over serviced, you should perform Type B inspections only when the mileage and hours equal that recommended by the manufacturer.

TYPE C (03) INSPECTION.— Type C annual safety inspection (SI)(ASI) is directed by COMSECOND/COMTHIRDNCB representatives. The maintenance supervisor is required to schedule 50 percent of CESE on site to receive a Type C safety

SAMPLE PM SCHEDULE

ACTIVITY _____
 YEAR _____

PM SCHED. GROUP	MONTH AND DAY SCHEDULE											
	JAN	FEB	MAR	APR	MAY	JUN	JUL	AUG	SEP	OCT	NOV	DEC
1	21		19		14		11		6		1	
2	22		20		15		12		9		4	
3	23		21		16		15		10		5	
4	24		22		17		16		11		6	
5	25		25		20		17		12		7	
6	28		26		21		18		13		8	
7	29		27		22		19		16		12	
8	30		28		23		22		17		13	
9	31		29		24		23		18		14	
10		1		1	27		24		19		15	
11		4		2	28		25		20		18	
12		5		3	29		26		23		20	
13		6		4	31		29		24		21	
14		7		5		3	30		25		22	
15		8		8		4	31		26		25	
16		11		9		5		1	27		26	
17		12		10		6		2	30		27	
18		13		11		7		5		1	29	
19		14		12		10		6		2		2
20		15		15		11		7		3		3
21		18		16		12		8		4		4
22		19		17		13		9		7		5
23		20		18		14		12		8		6
24		21		19		17		13		9		9
25		25		22		18		14		10		10
26		26		23		19		15		11		11
27		27		24		20		16		14		12
28	2	28		25		21		19		15		13
29	3		1	26		24		20		16		16
30	4		4	29		25		21		17		17
31	7		5	30		26		23		18		18
32	8		6		1	27		26		21		19
33	9		7		2	28		27		22		20
34	10		8		3		1	28		23		21
35	11		11		6		2	29		24		24
36	14		12		7		3	30		25		26
37	15		13		8		5			28		27
38	16		14		9		8		3	29		30
39	17		15		10		9		4	30		31
40	18		18		13		10		5	31		

Figure 1-19.—Sample of Preventive Maintenance Schedule.

inspection, using the appropriate PM Service and Inspection Guide. The relieving maintenance supervisor is required to schedule the other 50 percent of CESE on site. The Type C inspection is performed on a scheduled PM date that least effects operational commitments.

The Naval Construction Force (NCF) PM Service and Inspection Guide is outlined in the *Naval Construction Force Equipment Management Manual*, NAVFAC P-404, and *Equipment Management*, COMSECOND/COMTHIRDNCBINST 11200.1 Series.

Repair Parts

The NAVFAC repair parts allowance required for a NCF unit's assigned organic and augment equipment is contained in the Consolidated Seabee Allowance List (COSAL). These repair parts are funded by NAVFAC. COSALS are published under the authority contained in the NAVFAC or NAVSUP progrtim support agreement by Navy Ships Parts Control Center (SPCC), Mechanicsburg.

COSALS.— COSALS are both technical and supply documents. They are technical documents in that equipment nomenclature, operating characteristics, technical manuals, and so forth, are described in the Allowance Parts Lists. They are supply documents because they list all parts by manufacturer's code and part number, national stock number, unit of issue, price and quantity authorized by NAVFAC maintenance policy. Repair parts allowances are designed to provide a 90 percent effectiveness for 1,800 construction hours or 90 days support. The 90-day period is defined as a 3-month utilization period for CESE in new or like-new condition.

CATEGORIES.— Repair parts are divided into two basic categories: **parts peculiar**, NAVSUP modifier code 98, and **parts common**, NAVSUP modifier code 97. These are published in two separate COSALS. **Parts peculiar** are applicable only to specific makes or models of equipment. **Parts common** are general repair type of items and are not referenced to any specific equipment. Military and commercial operator's manuals, parts manuals, and maintenance manuals are listed in the parts peculiar to a COSAL. A descriptive account showing the method of entry and how to use the COSAL is contained in appendix F of the COSAL instruction.

The third category of repair parts is the NAVSUP modifier code 98. The mod 96 is a minimodifier 97 for use with an air detachment or an extended

detachment without jeopardizing the main body. The mod 96 repair parts allowance is designed to provide 90 days support.

Equipment Repair Order

The Equipment Repair Order (ERO), NAVFAC 11200/41 (figs. 1-20 and 1-21), and the ERO Continuation Sheet, NAVFAC 11200/41A (fig. 1-22), are used in the NCF to record cost of repairs, hours required for repairs, and total time that equipment is out of service. The ERO data help the NCF in budget planning, determining life expectancies of equipment, and predicting future equipment and training requirements. The Civil Engineer Support Office, Port Hueneme, California, uses the data to compile cost and utilization figures on each piece of USN-numbered equipment.

The ERO Continuation Sheet is used with the ERO when the number of repair items exceed the spaces provided on the ERO. The Equipment Repair Order (ERO) Work Sheet, NAVFAC 11200/41B (fig. 1-23), is used on site to record repair parts use and is filed with the complete ERO in the equipment history jacket.

The ERO is the sole authority to perform work on equipment regardless of whether the work is performed in the field or in the shop. An ERO is required each time labor exceeds 1 hour or materials are expended on scheduled PM, interim repairs, modernization or alteration of equipment, or deadline cycling or preservation of equipment. The Equipment Repair Order Log Sheet (fig. 1-15) is used to track the status of the EROs.

LIVE STORAGE PROGRAM

The Naval Construction Battalions deployed at main body sites are assigned numerous pieces of CESE to support contingency, emergency, and peacetime construction operations. Peacetime construction operations do not require the use of the full allowance of CESE that results in a number of pieces being placed in extended periods of nonutilization. This equipment absorbs maintenance man-hours, deteriorates, and could possibly be improperly used.

The maintenance supervisor controls the Live Storage Program developed to reduce maintenance hours spent on CESE. The Live Storage Branch is adequately staffed with skilled, experienced mechanics and equipment operators.

EQUIPMENT REPAIR ORDER (ERO)
NAVFAC 11200/41 (REV. 10-75) S/N 0108-LF-012-0208

1	UNIT NUMBER	2	ACTIVITY UIC	3	JOB ORDER NUMBER	4	LOCATION/ALLOWANCE	5	TYPE REPAIR	6	HR METER READING	7	HR METER READING	8	ERO NUMBER																																																																																																																																																																																												
9	A. DIRECT LABOR	10	B. INSPECTION	11	C. INDIRECT LABOR	12	D. MATERIAL	E. TOTALS			13	JULIAN DATE	14	NOVA PERFORMANCE																																																																																																																																																																																													
15	ESTIMATED HOURS	16	ACTUAL HOURS	17	ESTIMATED COST	18	ACTUAL COST (WHOLE \$)	19	A. EOPT AVAILABLE	20	B. INSPECTION START	21	C. SHOP START	22	D. STOP FOR PARTS	23	E. PARTS AVAILABLE	24	F. STOP FOR PARTS	25	G. PARTS AVAILABLE	26	H. COMPLETED	27	TIME	28	TIME	29	TIME	30	TIME	31	TIME	32	TIME	33	TIME	34	TIME	35	TIME	36	TIME	37	TRAIT TIME	38	TRAIT TIME	39	TRAIT TIME	40	TRAIT TIME	41	TRAIT TIME	42	TRAIT TIME	43	TRAIT TIME	44	TRAIT TIME	45	TRAIT TIME	46	TRAIT TIME	47	TRAIT TIME	48	TRAIT TIME	49	TRAIT TIME	50	TRAIT TIME	51	TRAIT TIME	52	TRAIT TIME	53	TRAIT TIME	54	TRAIT TIME	55	TRAIT TIME	56	TRAIT TIME	57	TRAIT TIME	58	TRAIT TIME	59	TRAIT TIME	60	TRAIT TIME	61	TRAIT TIME	62	TRAIT TIME	63	TRAIT TIME	64	TRAIT TIME	65	TRAIT TIME	66	TRAIT TIME	67	TRAIT TIME	68	TRAIT TIME	69	TRAIT TIME	70	TRAIT TIME	71	TRAIT TIME	72	TRAIT TIME	73	TRAIT TIME	74	TRAIT TIME	75	TRAIT TIME	76	TRAIT TIME	77	TRAIT TIME	78	TRAIT TIME	79	TRAIT TIME	80	TRAIT TIME	81	TRAIT TIME	82	TRAIT TIME	83	TRAIT TIME	84	TRAIT TIME	85	TRAIT TIME	86	TRAIT TIME	87	TRAIT TIME	88	TRAIT TIME	89	TRAIT TIME	90	TRAIT TIME	91	TRAIT TIME	92	TRAIT TIME	93	TRAIT TIME	94	TRAIT TIME	95	TRAIT TIME	96	TRAIT TIME	97	TRAIT TIME	98	TRAIT TIME	99	TRAIT TIME	100	TRAIT TIME																																
59	CUSTOMER OMR	60	PROJ COMP	61	SHOP DWR	62	DESCRIPTION	63	WORK DESCRIPTION	64	MECHANIC	65	NOTIFY SUPERVISOR	66	OF ALL ADDITIONAL WORK	67	W/C	68	FUNCTION CODE	69	W/C	70	FUNCTION CODE	71	W/C	72	FUNCTION CODE	73	W/C	74	FUNCTION CODE	75	W/C	76	FUNCTION CODE	77	W/C	78	FUNCTION CODE	79	W/C	80	FUNCTION CODE	81	W/C	82	FUNCTION CODE	83	W/C	84	FUNCTION CODE	85	W/C	86	FUNCTION CODE	87	W/C	88	FUNCTION CODE	89	W/C	90	FUNCTION CODE	91	W/C	92	FUNCTION CODE	93	W/C	94	FUNCTION CODE	95	W/C	96	FUNCTION CODE	97	W/C	98	FUNCTION CODE	99	W/C	100	FUNCTION CODE																																																																																																																								
101	ESTIMATED HOURS	102	ACTUAL HOURS	103	ESTIMATED COST	104	ACTUAL COST (WHOLE \$)	105	ESTIMATED HOURS	106	ACTUAL HOURS	107	ESTIMATED COST	108	ACTUAL COST (WHOLE \$)	109	ESTIMATED HOURS	110	ACTUAL HOURS	111	ESTIMATED COST	112	ACTUAL COST (WHOLE \$)	113	ESTIMATED HOURS	114	ACTUAL HOURS	115	ESTIMATED COST	116	ACTUAL COST (WHOLE \$)	117	ESTIMATED HOURS	118	ACTUAL HOURS	119	ESTIMATED COST	120	ACTUAL COST (WHOLE \$)	121	ESTIMATED HOURS	122	ACTUAL HOURS	123	ESTIMATED COST	124	ACTUAL COST (WHOLE \$)	125	ESTIMATED HOURS	126	ACTUAL HOURS	127	ESTIMATED COST	128	ACTUAL COST (WHOLE \$)	129	ESTIMATED HOURS	130	ACTUAL HOURS	131	ESTIMATED COST	132	ACTUAL COST (WHOLE \$)	133	ESTIMATED HOURS	134	ACTUAL HOURS	135	ESTIMATED COST	136	ACTUAL COST (WHOLE \$)	137	ESTIMATED HOURS	138	ACTUAL HOURS	139	ESTIMATED COST	140	ACTUAL COST (WHOLE \$)	141	ESTIMATED HOURS	142	ACTUAL HOURS	143	ESTIMATED COST	144	ACTUAL COST (WHOLE \$)	145	ESTIMATED HOURS	146	ACTUAL HOURS	147	ESTIMATED COST	148	ACTUAL COST (WHOLE \$)	149	ESTIMATED HOURS	150	ACTUAL HOURS	151	ESTIMATED COST	152	ACTUAL COST (WHOLE \$)	153	ESTIMATED HOURS	154	ACTUAL HOURS	155	ESTIMATED COST	156	ACTUAL COST (WHOLE \$)	157	ESTIMATED HOURS	158	ACTUAL HOURS	159	ESTIMATED COST	160	ACTUAL COST (WHOLE \$)	161	ESTIMATED HOURS	162	ACTUAL HOURS	163	ESTIMATED COST	164	ACTUAL COST (WHOLE \$)	165	ESTIMATED HOURS	166	ACTUAL HOURS	167	ESTIMATED COST	168	ACTUAL COST (WHOLE \$)	169	ESTIMATED HOURS	170	ACTUAL HOURS	171	ESTIMATED COST	172	ACTUAL COST (WHOLE \$)	173	ESTIMATED HOURS	174	ACTUAL HOURS	175	ESTIMATED COST	176	ACTUAL COST (WHOLE \$)	177	ESTIMATED HOURS	178	ACTUAL HOURS	179	ESTIMATED COST	180	ACTUAL COST (WHOLE \$)	181	ESTIMATED HOURS	182	ACTUAL HOURS	183	ESTIMATED COST	184	ACTUAL COST (WHOLE \$)	185	ESTIMATED HOURS	186	ACTUAL HOURS	187	ESTIMATED COST	188	ACTUAL COST (WHOLE \$)	189	ESTIMATED HOURS	190	ACTUAL HOURS	191	ESTIMATED COST	192	ACTUAL COST (WHOLE \$)	193	ESTIMATED HOURS	194	ACTUAL HOURS	195	ESTIMATED COST	196	ACTUAL COST (WHOLE \$)	197	ESTIMATED HOURS	198	ACTUAL HOURS	199	ESTIMATED COST	200	ACTUAL COST (WHOLE \$)				
199	CUSTOMER OMR	200	PROJ COMP	201	SHOP DWR	202	DESCRIPTION	203	WORK DESCRIPTION	204	MECHANIC	205	NOTIFY SUPERVISOR	206	OF ALL ADDITIONAL WORK	207	W/C	208	FUNCTION CODE	209	W/C	210	FUNCTION CODE	211	W/C	212	FUNCTION CODE	213	W/C	214	FUNCTION CODE	215	W/C	216	FUNCTION CODE	217	W/C	218	FUNCTION CODE	219	W/C	220	FUNCTION CODE	221	W/C	222	FUNCTION CODE	223	W/C	224	FUNCTION CODE	225	W/C	226	FUNCTION CODE	227	W/C	228	FUNCTION CODE	229	W/C	230	FUNCTION CODE	231	W/C	232	FUNCTION CODE	233	W/C	234	FUNCTION CODE	235	W/C	236	FUNCTION CODE	237	W/C	238	FUNCTION CODE	239	W/C	240	FUNCTION CODE	241	W/C	242	FUNCTION CODE	243	W/C	244	FUNCTION CODE	245	W/C	246	FUNCTION CODE	247	W/C	248	FUNCTION CODE	249	W/C	250	FUNCTION CODE	251	W/C	252	FUNCTION CODE	253	W/C	254	FUNCTION CODE	255	W/C	256	FUNCTION CODE	257	W/C	258	FUNCTION CODE	259	W/C	260	FUNCTION CODE	261	W/C	262	FUNCTION CODE	263	W/C	264	FUNCTION CODE	265	W/C	266	FUNCTION CODE	267	W/C	268	FUNCTION CODE	269	W/C	270	FUNCTION CODE	271	W/C	272	FUNCTION CODE	273	W/C	274	FUNCTION CODE	275	W/C	276	FUNCTION CODE	277	W/C	278	FUNCTION CODE	279	W/C	280	FUNCTION CODE	281	W/C	282	FUNCTION CODE	283	W/C	284	FUNCTION CODE	285	W/C	286	FUNCTION CODE	287	W/C	288	FUNCTION CODE	289	W/C	290	FUNCTION CODE	291	W/C	292	FUNCTION CODE	293	W/C	294	FUNCTION CODE	295	W/C	296	FUNCTION CODE	297	W/C	298	FUNCTION CODE	299	W/C	300	FUNCTION CODE

RECEIPT OF ABOVE ORDER AND EQUIPMENT IS HEREBY ACKNOWLEDGED

CONTRACTOR SIGNATURE/SHOP SUPERVISOR _____ CONTRACTING FIRM _____ DATE ARRIVED _____

PERMISSION TO EXCEED WORK ON ERO MUST BE AUTHORIZED BY REQUESTING ACTIVITY

71 INSP CODE _____ 72 INITIAL INSPECTOR (SIGNATURE) _____ 73 DATE _____ 74 INSP CODE _____ 75 FINAL INSPECTOR (SIGNATURE) _____ 76 DATE _____

77 CUSTOMER APPROVAL (SIGNATURE) _____ 78 ACT NAME _____ 79 DATE _____ 80 MAINTENANCE SUPERVISOR (SIGNATURE) _____ 81 DATE _____ 82 PAGE _____ 83 PAGE _____

Figure 1-20.—Equipment Repair Order (ERO), NAVFAC 11200/41.

<u>TYPE REPAIR (BLOCK 6)</u>			
01 A PM	009 Linings/Discs/Plates/Bands		
02 B PM	810 Drums/Rotors		
03 C PM	811 Backing Plate/Cams/Calipers		
04 Interim Repair	812 Hoses/Lines/Pipes/Fittings		
05 Overhaul	813 Master/Wheel Cylinder		
06 Breakdown (Field Repair)	814 Chambers/Disphragms		
07 Acceptance	815 Hydrovac/Vacuum Pump		
08 Repair for Stock	816 Valves, Governors, Tank		
09 Preservation and Storage Maintenance	817 Parking/Hand Brake		
10 Warranty	818 Other		
11 Rework			
12 Accident	<u>SUSPENSION</u>		
13 Shipping Inspection (CED)	C20 Springs		
14 Surveillance Inspection (CED)	C21 Shock Absorbers		
15 Operational Test (CED)	C22 Bars/Rods		
	C23 Other		
	<u>DRIVE TRAIN</u>		
	025 Clutch, Main Drive		
	026 Clutch, Control/Drum		
	027 Manual Transmission		
	028 Auto/Power Shift Transmission		
	029 Auxiliary Transmission		
	030 Transfer Cases/Power Dividers		
	031 Drive Shafts/U-Joints		
	032 Differentials		
	033 Drive Axles		
	034 Final Drive/Planetaries		
	035 Power Take-Off		
	036 Drive Balts/Chains		
	037 Torque Converter		
	038 Other		
	<u>ENGINE</u>		
	E40 Engine Assy, Gas		
	E41 Engine Assy, Diesel		
	E42 Engine Assy, Aux		
	E43 Air Intake System		
	E44 Blowers/Superchargers/Turbochargers		
	E45 Exhaust System		
	E46 Emission Control System		
	E49 Cooling System		
	E50 Other		
	<u>FUEL</u>		
	F52 Fuel System		
	F53 Fuel Transfer Pump		
	F54 Fuel Injection Pump		
	F55 Injectors/Nozzles		
	F56 Carburetor		
	F57 Gov/Throttle Controls		
	F58 Other		
	<u>ATTACHMENTS</u>		
	A01 Winch/POU		
	A02 Backhoe		
	A03 Boom		
	A04 Buckets/Blades/Edges		
	A05 Sheaves/Pulleys/Wire Rope		
	A06 Augers		
	A07 Other		
	<u>FUNCTIONAL CODES (BLOCK 45)</u>		
	<u>SERVICES</u>		
	01X Lubrication		
	20X Drain & Refill Engine Oil		
	03X Engine Oil Filter		
	23X Change Oil & Filters (Both 20X and 03X)		
	04X Fuel Filters and Screens		
	50X Drain & Refill Transmission Oil		
	06X Transmission Filters		
	56X Change Oil & Filters (Both 50X and 06X)		
	70X Drain & Refill Hydraulic Oil		
	08X Hydraulic Filters & Screens		
	78X Change Oil & Filters (Both 70X and 08X)		
	09X Drain & Refill Differential/Final Drive Oil/Filter		
	10X Air Cleaner/Filter		
	11X Battery Service/Recharge		
	12X Cleaning		
	13X Preservation		
	14X Other		
	<u>BRAKES</u>		
	809 Linings/Discs/Plates/Bands		
	810 Drums/Rotors		
	811 Backing Plate/Cams/Calipers		
	812 Hoses/Lines/Pipes/Fittings		
	813 Master/Wheel Cylinder		
	814 Chambers/Disphragms		
	815 Hydrovac/Vacuum Pump		
	816 Valves, Governors, Tank		
	817 Parking/Hand Brake		
	818 Other		
	<u>SUSPENSION</u>		
	C20 Springs		
	C21 Shock Absorbers		
	C22 Bars/Rods		
	C23 Other		
	<u>DRIVE TRAIN</u>		
	025 Clutch, Main Drive		
	026 Clutch, Control/Drum		
	027 Manual Transmission		
	028 Auto/Power Shift Transmission		
	029 Auxiliary Transmission		
	030 Transfer Cases/Power Dividers		
	031 Drive Shafts/U-Joints		
	032 Differentials		
	033 Drive Axles		
	034 Final Drive/Planetaries		
	035 Power Take-Off		
	036 Drive Balts/Chains		
	037 Torque Converter		
	038 Other		
	<u>ENGINE</u>		
	E40 Engine Assy, Gas		
	E41 Engine Assy, Diesel		
	E42 Engine Assy, Aux		
	E43 Air Intake System		
	E44 Blowers/Superchargers/Turbochargers		
	E45 Exhaust System		
	E46 Emission Control System		
	E49 Cooling System		
	E50 Other		
	<u>FUEL</u>		
	F52 Fuel System		
	F53 Fuel Transfer Pump		
	F54 Fuel Injection Pump		
	F55 Injectors/Nozzles		
	F56 Carburetor		
	F57 Gov/Throttle Controls		
	F58 Other		
	<u>ATTACHMENTS</u>		
	A01 Winch/POU		
	A02 Backhoe		
	A03 Boom		
	A04 Buckets/Blades/Edges		
	A05 Sheaves/Pulleys/Wire Rope		
	A06 Augers		
	A07 Other		
	<u>HYDRAULIC</u>		
	H60 Pump		
	H71 Pressure Control Valves		
	H72 Operating Valves		
	H63 Cylinders		
	H64 Motors		
	H65 Hoses/Lines/Pipes/Fittings		
	H66 Accumulators/Tanks		
	H67 Other		
	<u>ELECTRICAL</u>		
	J69 Replace Battery		
	J70 Replace Speedometer/Hourmeter		
	J71 Charging System		
	J72 Cranking System		
	J73 Lighting/Wiring System		
	J74 Electrical Cont-ols/Panels		
	J75 Ignition System		
	J76 Instruments/Gages		
	J77 Generators, Power/Welding		
	J78 Electric Drive Motors		
	J79 Electronic Circuits		
	J80 Other		
	<u>BODY AND FRAME</u>		
	K82 Cab/Sheet Metal		
	K83 Body/Bed		
	K84 Cushions/Seats/Canvas/Bows/Sideracks		
	K85 Painting/Marking		
	K87 Frame/Heat		
	K87 Bumper/Guard/Lifting Device		
	K88 Fifth Wheel/Trip Hitch/Towing Hook		
	K89 Outriggers/Landing Gear		
	K90 Other		
	<u>STEERING SYSTEM</u>		
	N92 Adjustments/Wheel/Alignment		
	N93 Steering Wheel/Box		
	N94 Steering Brakes/Clutches		
	N95 Linkages/Tie Rods/Etc.		
	N96 Ball Joints/King Pins		
	N97 Power Steering Pump/Belt		
	N98 Steering Cylinder/Hoses		
	N99 Other		
	<u>PNEUMATIC</u>		
	P01 Cylinders		
	P02 Compressors		
	P03 Separators/Filters		
	P04 Drifters		
	P05 Motors		
	<u>PRODUCTION EQUIPMENT</u>		
	Z43 Jaws/Hammer Mills		
	Z44 Roller/Liners/Concaves		
	Z45 Screens		
	Z47 Mixers		
	Z47 Dryers		
	Z48 Sced		
	Z49 Scales/Meters		
	Z50 Collector		
	Z51 Other		
	<u>WHEELS/TRACKS</u>		
	V33 Wheels/Rims		
	V34 Tires/Tubes		
	V35 Bearings/Seals/Packings		
	V36 Hub Assy/Studs/Nuts		
	V37 Rollers/Idlers/Sprockets		
	V38 Track Frame/Guards		
	V39 Rails/Pins/Crowders		
	W40 Track Adjuster/Accumulator		
	W41 Other		
	<u>HEATER/VENTILATING SYSTEM</u>		
	V26 Asphalt/Tank Heater		
	V27 Water Heater/Defroster		
	V28 Aggregate Heater		
	V29 Sced Heater		
	V30 Air Conditioning		
	V31 Other		
	<u>PRODUCT TRANSFER</u>		
	T19 Asphalt Pump		
	T20 Water/Mud Pump		
	T21 Refueling Pump		
	T22 Concrete Pump		
	T23 Conveyor Belt/Bucket/Screw		
	T24 Other		
	<u>HOSES/LINES/PIPES/FITTINGS</u>		
	P06 Controls		
	P07 Receivers/Oilers		
	P09 Other		
	<u>SAFETY EQUIPMENT</u>		
	S11 Fire Extinguisher		
	S12 Mirrors/Reflectors		
	S13 Windshield Wipers		
	S14 Mud Flaps/Guards/Shields		
	S15 Glass/Windshield		
	S16 Horn		
	S17 Other		

U.S. GOVERNMENT PRINTING OFFICE: 1982-505-106/8873 2-1

Figure 1-21.—Equipment Repair Order (ERO), NAVFAC 11200/41, Block Codes.

CESE is placed in live storage when there is no planned need for it for a period covering two PM cycles or 80 working days. CESE eligible for live storage must have an equipment evaluation code of A5 or above. All cranes are maintained in an active status and are under the control of the crane crew. To balance CESE through mileage or hours utilization, you should review low-mileage stored CESE for possible rotation with high-mileage active CESE with like equipment codes (EC).

All Equipment Status Boards must denote CESE that is assigned to live storage. The CESE in live storage is not for replacement of vehicles that are in the shop for PM or repairs. Live storage procedures are outlined in the *Naval Construction Force Equipment Management Manual*, NAVFAC P-404, the *Live Storage of CESE*, COMSECOND/COMTHIRDNCBINST 11200.9 series, and the *Maintenance of Active CESE at Mainbody Deployment Sites*, COMSECOND/COMTHIRD-NCBINST 11200.22 Series.

STORAGE OF PETROLEUM PRODUCTS

Bulk petroleum products are stored, inventoried, and issued by the battalion supply department, and fuel products are stored in the Alfa company yard. The maintenance supervisor maintains enough oil and lubricate supply in the mechanic's shop to perform maintenance operations.

The transportation supervisor is responsible for the storage of petroleum products used in the transportation pool. Storing petroleum products includes taking steps to prevent fires, water contamination, and ground pollution. Guidelines for storage and issue of flammable and combustible liquids are found in the U.S. Army Corps of Engineers, *Safety and Health Requirements Manual*, EM385-1-1.

EQUIPMENT ACQUISITION AND DISPOSITION

Equipment acquisition and disposition procedures for public works units are found in NAVFAC P-300. Second and Third NCB equipo offices notify battalions of equipment acquisition or equipment disposition instructions by message traffic. The procedures are found in the COMSECOND/COMTHIRDNCBINST 11200.1 Series. Civil Engineer Support Office (CESO) handles the acquisition and disposition of CESE for special operation units (SOUs).

BEEP

The purpose of the Battalion Equipment Evaluation Program (BEEP) is to use the full expertise and efforts of the two equipment forces to provide the relieving battalion the best possible turnover of Alfa company operations. Additionally, pass on all special knowledge of CESE maintenance, operation techniques, and provide a realistic in-depth condition evaluation of CESE allowance, facilities, tools, and materials.

The maintenance supervisor provides the transportation supervisor the scheduled CESE list for the BEEP. COMSECOND/COMTHIRDNCBINST 11200.1 Series recommends that CESE scheduling be accomplished by PM groups, with the appropriate number of groups scheduled each day to complete the BEEP within 10 working days. The 10 working days covers the cleaning, inspection, hands-on work, and final inspection of all CESE, and turnover of collateral equipage, tool kits, and other Alfa company-related areas.

BEEP preparation occurs the same time the battalion is preparing for the turnover of the Seabee Camp and construction projects. The equipment pool must have enough CESE cleaned and staged before commencement of the BEEP to ensure full use of all mechanics for 2 complete workdays. This requires a CESE assignment adjustment and the dispatching of CESE on a priority basis.

The Alfa company operation and maintenance supervisors generate a BEEP assignment list using the guidelines found in the COMSECONDCOMTHIRDNCBINST 11200.1 Series. Additionally, you need to develop a wash, grease, and CESE inspection crew to support the preparation of the CESE. The operator's maintenance performed at these stations provides expeditious flow of CESE as it goes through the mechanic shop.

Second and Third NCB equipo office representatives conduct a counterparts meeting before the commencement of the BEEP to set the procedures and guidelines for the BEEP. The representatives provide technical assistance and hold a comprehensive inspection on the overall effectiveness of the relieved battalion's equipment management program. Additionally, they conduct a random inventory of repair parts stock to determine the accuracy of the existing inventory, conduct a critique upon the completion of the BEEP, and prepare and submit a BEEP completion report (fig. 1-24) to Second and Third NCB with copies to appropriate information addressees.

NARRATIVE REPORT OF THE BEEP BETWEEN
NMCB AND NMCB

1. The COMCBLANT/COMCBPAC Equipment Office Representative(s), _____ arrived at NMCB _____ at Camp _____ at _____ on _____ for the purpose of observing the BEEP between NMCB _____ and NMCB _____.

2. A BEEP indoctrination briefing was presented at _____ on _____ to appropriate personnel.

3. The BEEP commenced at _____ on _____ and was completed at _____ on _____. Items of equipment located at _____ were not evaluated and are so indicated on enclosure _____.

a. Significant events of the BEEP were discussed at the Post-BEEP critique at _____ on _____. The following personnel were present:

_____ COMCBLANT Equipment Office Representative

_____ COMCBPAC Equipment Office Representative

b. A Post-BEEP briefing was conducted for the following personnel (appropriate Equipment Office).

NAME	TITLE	COMMAND

4. The condition of the Organic Allowance Equipment is as follows:

a. Excellent - _____ item- _____ percent

b. Good - _____ item- _____ percent

c. Fair - _____ item- _____ percent

d. Poor - _____ item- _____ percent

e. _____ percent of the equipment in the fair and poor categories is presently scheduled for replacement.

5. The condition of the Augment Equipment is as follows:

a. Excellent - _____ item- _____ percent

b. Good - _____ item- _____ percent

c. Fair - _____ item- _____ percent

d. Poor - _____ item- _____ percent

e. The following attachment shortage were noted:

6. Equipment correspondence files were reviewed for turnover to NMCB _____.

7. Equipment management and cost control records were reviewed. History jackets were purified. The following information has been compiled from NMCB _____ P.M. records for the period _____ through _____.

a. P.M.'s to interim repairs was _____ to _____.

8. Collateral equipage was inventoried and the total monetary value of shortages was:

From	No. of Items	Total Cost
a. Wreckers	_____	_____
b. Bridge and dock component	_____	_____
c. Rock drills	_____	_____
d. Earth augers	_____	_____
e. Lube skids	_____	_____
f. Woodworking shops	_____	_____
g. Machine shops	_____	_____
h. Fire truck	_____	_____
i. Collateral equipage	_____	_____
TOTAL	_____	_____

j. Funds were requested/received from COMCBPAC/COMCBLANT and the items have/have not been placed on order.

9. Deadline.

a. There were _____ items (_____ percent) on deadline at the commencement of the BEEP.

b. There were _____ items (_____ percent) on deadline at the conclusion of the BEEP.

10. General Comments/Commendatory Items:

Figure 1-24.—Outline of narrative report of Battalion Equipment Evaluation Program.

The transportation supervisors should track the status and location of all CESE and Equipment Evaluation Inspection Guides. At the end of each workday, the operations and maintenance supervisors request a transportation pool status of all the CESE that are EO inspected, are on the shop line, are in the shop, and are turned over with new BEEP stickers. Additionally, you should track CESE that has been washed, greased, staged, inspected, and processed through collateral equipage. Enforcement of good communication between the yard boss, dispatchers, cost control, and the EO inspectors enhances the control of equipment and paper work. Remember, paper work can be easily misplaced.

The transportation supervisors must inform all the Equipment Operators of the BEEP flow chart (fig. 1-25). The dispatchers should issue the

Equipment Evaluation Inspection Guide (fig. 1-26) to the EO equipment inspectors for each CESE inspected along with the Attachment Evaluation Inspection Guide (fig. 1-27), when required. The EO inspectors follow the procedures outlined on the inspection guides, and when completed, take the CESE to collateral equipage. The collateral equipage is jointly inspected by each collateral custodian, noting condition and deficiencies of collateral equipage for each CESE inspected. Both custodians must sign the inspection guide. The Equipment Evaluation Inspection Guides are delivered to the Alfa company operations supervisors who issue an Equipment Condition Code (fig. 1-28) for all CESE inspected by the EOs. The EO inspectors park the CESE on the shop line and take the paper work to cost control. The Equipment Operators must complete all

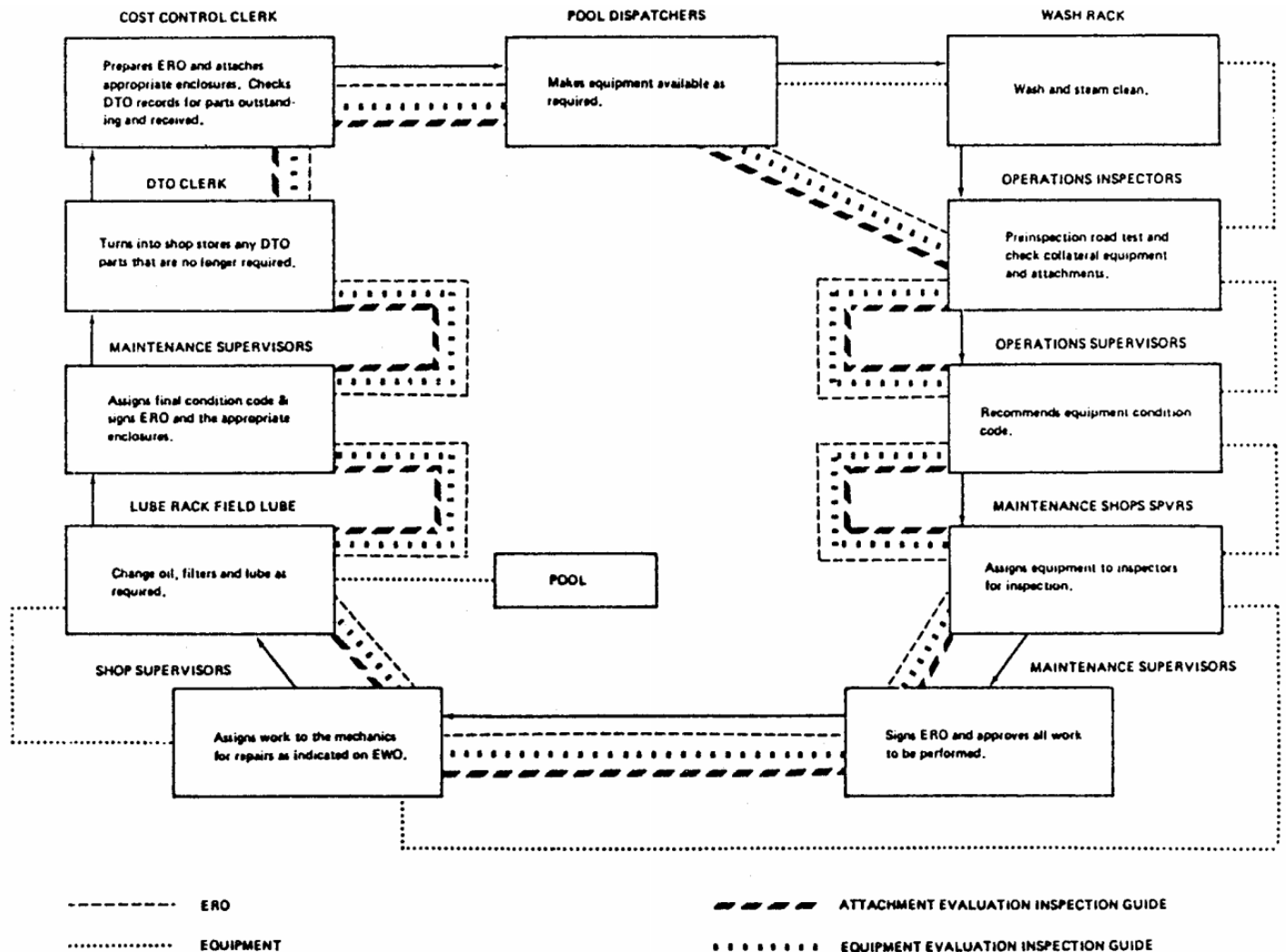

Figure 1-25.—Battalion Equipment Evaluation Program (BEEP) Flow Chart.

DATE

CODE		USN NO.	MILEAGE	HOURS	ENGINE SERIAL NO.
PRESTART INSPECTION	INSPECTORS	INITIALS	NMCB	INITIALS	NMCB
	COOLING SYSTEM	LEVEL	LEAKS	CONDITION	
	LUBRICATION SYSTEM	LEVEL	LEAKS	CONDITION	
	CHARGING SYSTEM	BATTERY LEVEL	BELTS	CABLES	CONNECTIONS
	LIGHTING SYSTEM	HEADLIGHTS	TAIL LIGHTS	BLACK OUT	INSTRUMENTS
		CLEARANCE	REFLECTORS	REMARKS	
	FUEL SYSTEM	LEVEL	LEAKS	CONDITION	
	TIRES	SIZE	TYPE TREAD	CONDITION	INFLATION
		MOUNTED SPARE SIZE		CONDITION	INFLATION
	TRACKS	RAILS	PINS	SHOES	SPROCKETS
		IDLERS	REMARKS		
		AUTO TRANS FLUID		MIRRORS	LUG NUTS
	MISCELLANEOUS	CONTROLS	CABLES	DOORS	GLASS
		UPHOLSTERY	BODY CONDITION		
REMARKS					
ENGINE RUNNING	INSPECTORS	INITIALS	NMCB	INITIALS	NMCB
	ACCESSORIES	INSTRUMENTS	WARNING DEVICES HORN		
		W/S WIPERS	BRAKES	CLUTCH	HAND BRAKE
	LEAKS	ENGINE	TRANSMISSION		TRANSFER CASE
		DIFFERENTIALS	BRAKES	STEERING	WINCH
	ENGINE PERFORMANCE	STARTING	IDLING	FULL LOAD	
		PARTIAL LOAD			REMARKS
		STEERING	BRAKES	CLUTCH	TRANSMISSION
	VEHICLE PERFORMANCE	DIFFERENTIALS	TRANSFER CASE	PTO	WINCH
		HYD SYSTEM	DRIVE SHAFTS	UNUSUAL NOISE/MOTION	
REMARKS					

Figure 1-26A.—Equipment Evaluation Inspection Guide (Front).

CODE		USN NO.	MILEAGE	HOURS	ENGINE SERIAL NO.	
INVENTORY	INSPECTORS	INITIALS	NMCB	INITIALS	NMCB	
	COLLATERAL EQUIPAGE INVENTORY	DISCREPANCIES/SHORTAGES				
	OPERATIONS SUPERVISORS	INITIALS	NMCB	RECOMMENDED CONDITION CODE		
		INITIALS	NMCB	RECOMMENDED CONDITION CODE		
REMARKS						
SHOP INSPECTION AND REPAIR	INSPECTORS	INITIALS	NMCB	INITIALS	NMCB	
	MOUNTING BOLTS	ENGINE	TRANSMISSION	AXLES	TRANSFER CASE	
		SPRINGS	BODY	CAB	FENDERS	
		FUEL TANKS	REMARKS			
	MISCELLANEOUS	EXHAUST SYSTEM	SPRINGS	SHOCKS	TIE RODS	
		DRAG LINK	IDLER ARM	CONTROL LINKAGE		
	AIR INTAKE SYSTEM	CLEANER COND.	PIPING CONNECT	TURBOCHARGER, BLOWER		
	FRONT WHEELS	BRAKE LINING	BEARING ASSEMBLIES			SEALS
		BOOTS	DRUMS	CYLINDERS	BACKING PLATE	
		SHOE MOUNT	ADJUST MECH	REMARKS		
	REAR WHEELS	BRAKE LINING	BEARING ASSEMBLIES			SEALS
		BOOTS	DRUMS	CYLINDERS	BACKING PLATE	
		SHOE MOUNT	ADJUST MECH	REMARKS		
	SHOP SUPERVISOR	MAKE MINOR REPAIRS/ORDER PARTS (Initials)				
		FINAL INSPECTION (Initial)				

Figure 1-26B.—Equipment Evaluation Inspection Guide (Back).

<p>OVERALL CONDITION Circle Applicable Code (below)</p> <p>The following is a complete listing of the possible codes with a brief description.</p>		
Code	Description	
A1	Serviceable/Unused-Good	F8 Unserviceable Repairable-Repairs Required-Fair
A2	Serviceable/Unused-Fair	F9 Unserviceable Repairable-Repairs Required-Poor
A3	Serviceable/Unused-Poor	G7 Unserviceable Incomplete-Repairs Required-Good
A4	Serviceable/Used-Good	G8 Unserviceable Incomplete-Repairs Required-Fair
A5	Serviceable/Used-Fair	G9 Unserviceable Incomplete-Repairs Required-Poor
A6	Serviceable/Used-Poor	SX Unserviceable Scrap/Salvage
		SS Unserviceable Scrap/Scrap
F7	Unserviceable Repairable-Repairs Required-Good	
<p>ABOVE CONDITION AGREED TO BY MAINTENANCE SUPERVISORS FROM BOTH BATTALIONS</p>		
<p>NMCB (SIGNATURE)</p>		<p>NMCB (SIGNATURE)</p>
<p>COMSECOND/COMTHIRDNCB Equip. Rep. (Signature)</p>		<p>Date Code</p>

Figure 1-26B.—Equipment Evaluation Inspection Guide (Back)—Continued.

CESE inspections 2 or 3 days before the planned BEEP completion date, ensuring that all CESE is processed through the mechanic shop.

Mechanic inspectors conduct BEEP inspections using the Equipment Evaluation Inspection Guide. A safety inspection Equipment Repair Order (ERO) is developed for all CESE assigned. Any discrepancies listed on the evaluation guide is transferred to an ERO for repairs. Maintenance supervisors determine what repairs can be accomplished based on the work force, space, and repair parts available. Additionally, they inspect all maintenance records, review and account for all maintenance correspondence, and inventory and inspect all permanent Alfa company shop equipment. The maintenance supervisors review all the Equipment Evaluation Inspection Guides and approve all Equipment Condition Codes (fig. 1-28) for each CESE.

After the final inspections of all CESE, the mechanics place NMCB unit identification marking decals (red-diamond shape for organic equipment and white-diamond shape for augment allowance equipment) in the correct locations. The dispatcher signs Block 77 of the EROs for customer approval of all CESE "BEEPed."

COMSECOND or COMTHIRD equipo reviews and approves all BEEP equipment evaluation guides and EROs. At the completion of all Alfa company inspections, the relieving equipment officer signs the TAB A as acceptance of the equipment for the relieving battalion.

LICENSE PROGRAM

A properly administered license program ensures only thoroughly trained personnel who are physically

DATE

I.D. NUMBER	DESCRIPTION	LOCATION																																																									
ASSIGNED TO CODE	USN NO.	MOUNTED/UNMOUNTED																																																									
	INSPECTORS	INITIALS	NMCB	INITIALS	NMCB																																																						
	PRESTART INSPECTION	FRAME	MOUNTINGS	MOUNTING HARDWARE																																																							
		CONTROLS	CABLES/SHEAVES		BUSHINGS/BEARINGS																																																						
		HOSES	HYD SYSTEM	CUTTING EDGE/TEETH																																																							
	REMARKS																																																										
	INSPECTORS	INITIALS	NMCB	INITIALS	NMCB																																																						
	OPERATIONAL INSPECTION	PARTIAL LOAD		FULL LOAD																																																							
		REMARKS																																																									
	OPERATIONS SUPERVISOR	INITIALS	NMCB	RECOMMENDED CONDITION CODE																																																							
		INITIALS	NMCB	RECOMMENCED CONDITION CODE																																																							
REMARKS																																																											
	SHOP SUPERVISOR	MAKE MINOR REPAIRS/ORDER PARTS (Initials)																																																									
		FINAL INSPECTION (Initials)																																																									
<p>OVERALL CONDITION Circle Applicable Code (below)</p> <p>The following is a complete listing of the possible codes with a brief description.</p> <table style="width: 100%; border: none;"> <tr> <td style="width: 10%;">Code</td> <td style="width: 40%;">Description</td> <td style="width: 10%;"></td> <td style="width: 10%;"></td> <td style="width: 10%;"></td> <td style="width: 10%;"></td> </tr> <tr> <td>A1</td> <td>Serviceable/Unused-Good</td> <td>F8</td> <td>Unserviceable Repairable-Repairs Required-Fair</td> <td></td> <td></td> </tr> <tr> <td>A2</td> <td>Serviceable/Unused-Fair</td> <td>F9</td> <td>Unserviceable Repairable-Repairs Required-Poor</td> <td></td> <td></td> </tr> <tr> <td>A3</td> <td>Serviceable/Unused-Poor</td> <td>G7</td> <td>Unserviceable Incomplete-Repairs Required-Good</td> <td></td> <td></td> </tr> <tr> <td>A4</td> <td>Serviceable/Used-Good</td> <td>G8</td> <td>Unserviceable Incomplete-Repairs Required-Fair</td> <td></td> <td></td> </tr> <tr> <td>A5</td> <td>Serviceable/Used-Fair</td> <td>G9</td> <td>Unserviceable Incomplete-Repairs Required-Poor</td> <td></td> <td></td> </tr> <tr> <td>A6</td> <td>Serviceable/Used-Poor</td> <td>SX</td> <td>Unserviceable Scrap/Salvage</td> <td></td> <td></td> </tr> <tr> <td></td> <td></td> <td>SS</td> <td>Unserviceable Scrap/Scrap</td> <td></td> <td></td> </tr> <tr> <td>F7</td> <td>Unserviceable Repairable-Repairs Required-Good</td> <td></td> <td></td> <td></td> <td></td> </tr> </table>						Code	Description					A1	Serviceable/Unused-Good	F8	Unserviceable Repairable-Repairs Required-Fair			A2	Serviceable/Unused-Fair	F9	Unserviceable Repairable-Repairs Required-Poor			A3	Serviceable/Unused-Poor	G7	Unserviceable Incomplete-Repairs Required-Good			A4	Serviceable/Used-Good	G8	Unserviceable Incomplete-Repairs Required-Fair			A5	Serviceable/Used-Fair	G9	Unserviceable Incomplete-Repairs Required-Poor			A6	Serviceable/Used-Poor	SX	Unserviceable Scrap/Salvage					SS	Unserviceable Scrap/Scrap			F7	Unserviceable Repairable-Repairs Required-Good				
Code	Description																																																										
A1	Serviceable/Unused-Good	F8	Unserviceable Repairable-Repairs Required-Fair																																																								
A2	Serviceable/Unused-Fair	F9	Unserviceable Repairable-Repairs Required-Poor																																																								
A3	Serviceable/Unused-Poor	G7	Unserviceable Incomplete-Repairs Required-Good																																																								
A4	Serviceable/Used-Good	G8	Unserviceable Incomplete-Repairs Required-Fair																																																								
A5	Serviceable/Used-Fair	G9	Unserviceable Incomplete-Repairs Required-Poor																																																								
A6	Serviceable/Used-Poor	SX	Unserviceable Scrap/Salvage																																																								
		SS	Unserviceable Scrap/Scrap																																																								
F7	Unserviceable Repairable-Repairs Required-Good																																																										
ABOVE CONDITION AGREED TO BY MAINTENANCE SUPERVISORS FROM BOTH BATTALIONS																																																											
NMCB (SIGNATURE)			NMCB (SIGNATURE)																																																								
COMSECOND/COMTHIRDNCB Equip. Rep. (Signature)			Date	Code																																																							

Figure 1-27.—Attachment Evaluation Inspection Guide.

OVERALL CONDITION	Circle Applicable Code (below)	
The following is a complete listing of the possible codes with a brief description.		
Code	Description	
A1	Serviceable/Unused-Good	F8 Unserviceable Repairable-Repairs Required-Fair
A2	Serviceable/Unused-Fair	F9 Unserviceable Repairable-Repairs Required-Poor
A3	Serviceable/Unused-Poor	G7 Unserviceable Incomplete-Repairs Required-Good
A4	Serviceable/Used-Good	G8 Unserviceable Incomplete-Repairs Required-Fair
A5	Serviceable/Used-Fair	G9 Unserviceable Incomplete-Repairs Required-Poor
A6	Serviceable/Used-Poor	SX Unserviceable Scrap/Salvage
		SS Unserviceable Scrap/Scrap
F7	Unserviceable Repairable-Repairs Required-Good	

Figure 1-28.—Equipment Condition Codes.

and mentally qualified are licensed as Equipment Operators.

LICENSE EXAMINER

The license examiner should be the best qualified licensed equipment operator available. The license examiner is appointed by letter by the commanding officer and has the responsibility to become familiar with and maintain a library of the following publications:

1. *Storage and Materials Handling*, DODINST 4145.19-R-1
2. *Motor Vehicles Management Acquisition and Use*, OPNAVINST 11240.16A *Motor*
3. *Vehicles Driver's Handbook*, NAVSEA OP-2239, and *Ammunition, Explosives, and Related Hazardous Materials*
4. *Management of Transportation Equipment*, NAVFAC P-300
5. *Testing and Licensing of Construction Equipment Operators*, NAVFAC P-306 6.

6. *Management of Weight-Handling Equipment Maintenance and Certification*, NAVFAC P-307
7. *Navy Driver's Handbook*, NAVFAC MO-403
8. *Naval Construction Force Equipment Management Manual*, NAVFAC P-404
9. *Naval Construction Force Safety Manual*, COMSECOND/COMTHIRDNCBINST Series
10. *Federal Motor Carrier Safety Regulations*, Parts 390-397

Additionally, the license examiner maintains a license file under lock and key for each licensed operator in the command. These files are maintained to provide information on the types of equipment the operator is qualified to operate, applicants background and experience, examination findings, special requirements, traffic violations, and accident history. The license examiner must comply with the Privacy Act of 1974 in the maintenance of all files of licensed operators. The license examiner maintains a tickler file of each operator's license expiration date and ensures all personnel are properly trained on the equipment before issuing the Operator's

OP 346 11/85 USUPM FPM Chapter 930		U.S. Government Motor Vehicle Operator's Identification Card		Card No.	Restrictions															
Name of Operator <i>(Not Transferable)</i>		Sex	Signature of Operator <i>(Not valid until signed)</i>		<table border="1"> <tr><th colspan="3">QUALIFIED TO OPERATE</th></tr> <tr> <th>Type Vehicle and/or Equipment</th> <th>Capacity</th> <th>Qualifying Official</th> </tr> <tr><td> </td><td> </td><td> </td></tr> <tr><td> </td><td> </td><td> </td></tr> <tr><td> </td><td> </td><td> </td></tr> </table>	QUALIFIED TO OPERATE			Type Vehicle and/or Equipment	Capacity	Qualifying Official									
QUALIFIED TO OPERATE																				
Type Vehicle and/or Equipment	Capacity	Qualifying Official																		
Date of Birth	Social Security No.		Name and Location of Issuing Unit																	
Height	Weight	Hair Color	Eye Color	Signature and Title of Issuing Official																
Date Issued	Date Expires																			
The holder of this card is qualified to operate U.S. Government vehicles and/or equipment specified, subject to the restrictions set forth on the other half of this card. Card must be carried at all times when operating Government vehicles.					<table border="1"> <tr><th colspan="3">OTHER RECORDS <i>(Optional)</i></th></tr> <tr><td> </td><td> </td><td> </td></tr> <tr><td> </td><td> </td><td> </td></tr> <tr><td> </td><td> </td><td> </td></tr> </table>	OTHER RECORDS <i>(Optional)</i>														
OTHER RECORDS <i>(Optional)</i>																				
NSN 7540-00-634-3999					50346-101															

OF-346, Front and Back

Figure 1-29.—Operator's Identification Card, OF-346.

Identification Card, OF-346 (fig. 1-29), or Construction Equipment Operator License, NAVFAC 11 260/2 (fig. 1-30).

APPLICATION FORMS

The proper form used when applying for an automotive or material-handling equipment license is the Application for Vehicle Operator's Identification Card, NAVFAC 11240/10 (figs. 1-31 and 1-32). The proper form to use when applying for a license for construction equipment is the Application for Construction Equipment Operator License, NAVFAC 11260/1 (figs. 1-33 and 1-34). All application forms are completed by the applicants and signed by the company commander or company chief. The NAVFAC P-300 states "Military personnel may operate government-owned or leased vehicles under 10,000 pounds GVW without a government license." However, all personnel in the NCF and special operating units (SOUs) who operate government-owned or rented equipment under the maintenance management policy of the NAVFAC P-404 shall be qualified and have in possession a valid U.S. government operator's license, covering the size and type of vehicle to be operated.

PHYSICAL FITNESS INQUIRY FORM

Applicants for the U.S. Government Motor Vehicle Operator's Identification Card, OF-346 (fig. 1-29), and the Construction Equipment Operator License, NAVFAC 11260/2 (fig. 1-30), are required to complete a Physical Fitness Inquiry for Motor Vehicle Operators, Standard Form 47 (fig. 1-35). The license

CONSTRUCTION EQUIPMENT OPERATOR LICENSE					CARD NO.
NAVFAC 11260 2 (9-74)					DATE ISSUED
Supersedes NAVJUGES 7754					DATE EXPIRES
S/M 9185-11 002-15TH					
NAME OF OPERATOR					
DATE OF BIRTH	COLOR OF HAIR	COLOR OF EYES	HEIGHT	WEIGHT	
THE HOLDER OF THIS CARD IS QUALIFIED TO OPERATE U.S. GOVERNMENT HEAVY EQUIPMENT AS SPECIFIED ON REVERSE OF THIS CARD					
SIGNATURE OF ISSUING OFFICIAL			TITLE		
			CERTIFIED EXAMINER		
SIGNATURE OF OPERATOR			TITLE OF POSITION		
NOT TRANSFERABLE Card must be carried at all times when operating Government equipment.					

(Front)

QUALIFIED TO OPERATE				
EQUIPMENT TYPE	SIZE AND CAPACITY	ATTACHMENT	TYPE CON-TROLS	EXAM.
* U.S. Government Printing Office: 1984-705-012/7317 2-1				

(Back)

Figure 1-30.—Construction Equipment Operator License, NAVFAC 11260/2.

APPLICATION FOR VEHICLE OPERATOR'S IDENTIFICATION CARD
 NAVFAC 11240/10 (REV. 10-76) S/N 0105-LF-012-4055

(See Privacy Act Statement and Instructions on reverse)

NEW RENEWAL

PART I - APPLICATION

1. NAME (Last, First, Middle Initial)		2. RANK/RATE/GRADE AND TITLE		3. ACTIVITY	
4. AGE	5. DATE OF BIRTH		6. PLACE OF BIRTH		7. SOCIAL SECURITY NUMBER
8. SEX		9. WEIGHT	10. HEIGHT	11. COLOR OF HAIR	12. COLOR OF EYES
13. SHOP NAME/NUMBER AND APPLICANT'S BADGE NUMBER			14. SUPERVISOR (Name)		15. PHONE NUMBER
16a. TYPE OF IDENTIFICATION CARD (Check)		16b. TYPES OF VEHICLES TO BE OPERATED (Check)			
<input checked="" type="checkbox"/>	REGULAR	<input checked="" type="checkbox"/>	PASSENGER CAR	<input type="checkbox"/>	BUS (GAS AND DIESEL)
<input type="checkbox"/>	RESTRICTED	<input type="checkbox"/>	PICKUP TRUCK	<input type="checkbox"/>	TRUCK TRACTOR & SEMITRAILER
<input type="checkbox"/>	EXPLOSIVE	<input type="checkbox"/>	TRUCKS TO 2 TONS	<input type="checkbox"/>	FIRE TRUCK
<input type="checkbox"/>	EMERGENCY VEHICLE	<input type="checkbox"/>	TRUCKS TO 5 TONS	<input type="checkbox"/>	AMBULANCE
<input type="checkbox"/>	AVGAS REFUELER	<input type="checkbox"/>	TRUCKS TO 10 TONS	<input type="checkbox"/>	MOTORCYCLE & SCOOTERS
<input type="checkbox"/>		<input type="checkbox"/>		<input type="checkbox"/>	TRUCK 4 x 4
<input type="checkbox"/>		<input type="checkbox"/>		<input type="checkbox"/>	TRUCK 6 x 6
<input type="checkbox"/>		<input type="checkbox"/>		<input type="checkbox"/>	TRUCK FIRE/CRASH
<input type="checkbox"/>		<input type="checkbox"/>		<input type="checkbox"/>	TRUCK TANK
<input type="checkbox"/>		<input type="checkbox"/>		<input type="checkbox"/>	OTHER (Explain below)

17. EXPLANATION

18. VALID STATE VEHICLE OPERATOR'S LICENSE(S)

19. SIGNATURE OF REQUESTING OFFICIAL	Date
--------------------------------------	------

PART II - OPERATOR'S PAST PERFORMANCE RECORD

DATE	VEHICLE TYPE/SIZE	LICENSES ISSUED		NO. YRS. DRIVING EXP.	LIST ACCIDENTS, VIOLATIONS, ARRESTS (If any) AND ACTION TAKEN
		STATE	OTHER		
1	2	3	4	5	6

7. I CERTIFY THE ABOVE TO BE CORRECT.	SIGNATURE OF APPLICANT	DATE
---------------------------------------	------------------------	------

PART III - EXAMINATION RESULTS

1. SCORES IN DRIVING TESTS	✓		2. SCORES ACHIEVED IN TESTS	✓		3. GOVERNMENT VEHICLES AUTHORIZED TO OPERATE (List)
	SAT	UNSAT		SAT	UNSAT	
a. ROAD TEST			a. WRITTEN			
b. EQUIPMENT INSPECTION			b. PHYSICAL			
4. REMARKS						

PART IV - ACTION BY ADMINISTERING OFFICIAL

1. IDENTIFICATION CARD ISSUED	2. IDENTIFICATION CARD NUMBER	DATE ISSUED (Mo., Day, Yr.)	EXPIRATION DATE (Mo., Day, Yr.)
<input type="checkbox"/> YES <input type="checkbox"/> NO*			
3. IDENTIFICATION CARD MARKED "VOID UNLESS ACCOMPANIED BY VALID STATE LICENSE"			
<input type="checkbox"/> YES <input type="checkbox"/> NO*			
4. OPERATOR INSTRUCTED TO TURN IN IDENTIFICATION CARD UPON LOSS OR SUSPENSION OF STATE DRIVER'S LICENSE			
<input type="checkbox"/> YES <input type="checkbox"/> NO*			
*IF "NO" EXPLAIN UNDER REMARKS		5. SIGNATURE OF ADMINISTERING OFFICIAL	
		Date	

Figure 1-31.—Application for Vehicle Operator's Identification Card, NAVFAC 11240/10 (Front).

INSTRUCTIONS FOR COMPLETING APPLICATION FOR VEHICLE OPERATOR'S IDENTIFICATION CARD
NAVFAC 11240/10 (REV. 10-75)

PRIVACY ACT STATEMENT

Authority to request this information is derived from Title 40 United States Code 471. Purpose of this form is to obtain information to determine whether an individual is qualified to operate a government vehicle and/or equipment. Information is used by agency transportation officials and may be used by government and civil law enforcement authorities for court action. Providing information for this form is mandatory. If the information is not provided, the individual would be denied the privilege of operating a government vehicle and/or equipment.

GENERAL

Prepare in duplicate. File original in applicant's personnel jacket and retain copy in issuing office. Use typewriter or ball-point pen.

PART I - APPLICATION

1. Self-explanatory.
2. Enter military rank/rate or civilian grade and title.
3. Enter name and location of activity. Abbreviations may be used.
4. Self-explanatory.
5. Enter day, month and year of birth.
6. Enter city/town and state of birth.
7. Self-explanatory.
8. Enter male or female.
9. Self-explanatory.
10. Enter height in feet and inches; i.e., 6' 2".
11. Enter color of hair; i.e., brown, black, gray.
12. Enter color of eyes; i.e., blue, brown, hazel.
13. Enter shop name and number, plus applicant's badge number.
14. Enter the name of the applicant's supervisor.
15. Enter the telephone number of the applicant's supervisor; i.e., 74056.
16. a. Check type of identification card applied for.
b. Check types of vehicles to be operated for which operator's identification card is to be issued.
17. List other types of vehicles that applicant is required to operate not listed under 16 b.
18. Enter current valid state (*name and number*) vehicle operator's license(s).
19. Signature of requesting official; i.e., Commanding Officer or designated representative and date.

PART II - OPERATOR'S PAST PERFORMANCE RECORD

1. Self-explanatory.
2. Enter vehicle type/size that applicant is or has been authorized to operate.
3. Enter date of issue of previous or present State vehicle operator's license.
4. Enter date of issue of previous identification cards (*if any*).
5. Enter number of years of driving experience, both civilian and military, for each license entry.
6. Briefly list accidents, violations, arrests, if any, and action taken.
7. Signature of applicant and date.

PART III - EXAMINATION RESULTS

- 1 & 2. Check appropriate boxes.
3. List types of Government vehicles authorized to operate; i.e., pickup truck, truck tank.
4. Enter remarks, if any, the examiner considers necessary; i.e., restrictions, driving weaknesses, outstanding qualifications.

PART IV - ACTION BY ADMINISTERING OFFICIAL

1. Check appropriate box.
2. Enter serial number of identification card issued, date issued, and expiration date.
3. The phrase "Void unless accompanied by valid state license" may be over stamped on the card or typed on the back under "Other Records."
4. Check appropriate box.
5. Signature of administering official and date.

NAVFAC 11240/10 (REV. 10-75) (BACK)

Figure 1-32.—Application for Vehicle Operator's Identification Card, NAVFAC 11240/10 (Back).

Read the PRIVACY ACT STATEMENT on reverse before completing this application
APPLICATION FOR CONSTRUCTION EQUIPMENT OPERATOR LICENSE
 NAVFAC 11260/1 (REV. 6/78)

NAV 0000-17-013-0000

PART I - APPLICATION

1. NAVAL ACTIVITY	2. APPLICANT'S NAME	3. RANK, RATE OR CIVILIAN STATUS
4. DEPARTMENT, DIVISION AND/OR SHOP ASSIGNED TO		5. APPLICANT'S JOB TITLE
6. DESCRIPTION OF EQUIPMENT LICENSE REQUESTED		
(a) TYPE OF EQUIPMENT	(b) TYPE OF CONTROL	(c) TYPE OF ATTACHMENT
7. STATEMENT OF QUALIFYING EXPERIENCE		

8. DESCRIPTION OF EQUIPMENT APPLICANT IS CURRENTLY LICENSED TO OPERATE

9. SPONSOR'S STATEMENT OF APPLICANT'S READINESS AND/OR PREPARATORY TRAINING FOR TEST *(NOTE: The sponsor can be either a qualified instructor or licensed operator)*

Signature _____
 _____ Sponsor

PART II - REQUEST FOR ADMINISTERING TESTS AND EXAMINATIONS AND ISSUING LICENSE

FROM: _____ Date _____
 TO: _____

It is requested that the license for equipment described in item 6 above be issued to this applicant upon his successful completion of the required examinations and tests.

Signature _____
 Title _____
 _____ Department, Division or Shop Supervisor

(OVER)

Figure 1-33.—Application for Construction Equipment Operator License, NAVFAC 1120/1 (Front).

PART III - ACTION ON SUBJECT APPLICATION

FROM: License Office
TO: ALFA Company Transportation Officer

Date 5/12/-

- Arrangements will be made to proceed with examinations and tests as requested.
- No action will be taken on this application for the following reason:

Signature J. J. Jants, SO1, USN
Title Examiner

PART IV - LICENSE ACTION

FROM: License Office
TO: ALFA Company Transportation Officer

Date 5/12/-

- The subject license has been issued to the applicant as requested.
- The applicant has failed his physical examination.
- The applicant has failed to qualify for the subject license.

_____ number of days (the established waiting period) must elapse before a new application may be made for this license.

Signature J. J. Jants, SO1, USN
Title Examiner

PRIVACY ACT STATEMENT

This statement is provided in compliance with the provisions of the Privacy Act of 1974 (PL-93-579) (N00011 C02) which require that Federal agencies must inform individuals who are requested to furnish information about themselves as to the following facts concerning the information requested.

1. AUTHORITY: 5 U.S.C. 301 Departmental Regulations
2. PRINCIPAL PURPOSE(S): To apply for a license to operate government-owned vehicles.
3. ROUTINE USE(S): To be used by agency officials to determine the employee's eligibility to operate government-owned vehicles. May be used by safety and security officials to verify individual's qualifying experience.
4. MANDATORY OR VOLUNTARY DISCLOSURE: The disclosure of information requested is voluntary. However, failure to complete the form will result in nonissuance of license.

Figure 1-34.—Application for Construction Equipment Operator License, NAVFAC 11260/1 (Back).

PHYSICAL FITNESS INQUIRY FOR MOTOR VEHICLE OPERATORS

1. Last Name—First Name—Middle Name	2. Date of Birth	3. Title of Position
4. Home Address (Number, street or RFD, city or town, State and ZIP code)		5. Employing Agency

6. Have you ever had or have you now (Place check at left of each item)

YES	NO		YES	NO	
		Poor vision in one or both eyes			Arthritis, rheumatism, swollen or painful joints
		Eye disease			Loss of hand, arm, foot, or leg
		Poor hearing in one or both ears			Deformity of hand, arm, foot, or leg
		Diabetes			Nervous or mental trouble of any kind
		Palpitation, chest pain, or shortness of breath			Blackouts or epilepsy
		Dizziness or fainting spells			Sugar or albumin in urine
		Frequent or severe headaches			Excessive drinking habit (Alcohol)
		High or low blood pressure			Other serious defects or diseases
		Drug or narcotic habit			

7. If your answer is "Yes" to one or more of the above questions, explain fully in this space, indicating date of original condition and current status:

8. (A) Do you wear glasses (or contact lenses) while driving? YES NO
 (B) Do you wear a hearing aid? YES NO

PRIVACY ACT NOTICE

Authority: This information is provided pursuant to Public Law 93-579 (Privacy Act of 1974), December 31, 1974, for individuals completing Standard Form 47, Physical Fitness Inquiry for Motor Vehicle Operators. U.S. Code, Title 5, section 301.

Purposes and Uses: SF 47 is used to ascertain the physical fitness of Federal employees, whose jobs are not regular motor vehicle operating jobs, to drive Government-owned

motor vehicles. It is also used in the renewal of authorizations for all employees. Based on the information provided, employees may be referred for a medical examination before being given a renewal.

Effects of Nondisclosure: Nondisclosure of this information will result in the employee not being authorized to drive a Federal motor vehicle. The disclosure of this information is mandatory when an employee's job requires driving a Federal motor vehicle and is voluntary otherwise.

I certify that my answers above are full and true, and I understand that a willfully false statement or dishonest answer to any question may be grounds for cancellation of my eligibility or my dismissal from the service and is punishable by law.

Signature	Date
-----------	------

REVIEW AND CERTIFICATION BY DESIGNATED OFFICIAL

I certify that I have reviewed this physical fitness inquiry form and other available information regarding the physical condition of the applicant, and that I have made the following determination:

- There is no information on this form or otherwise available to indicate that the applicant should be referred for physical examination.
- On the basis of items checked on this form or other information this applicant must be referred for physical examination before he is authorized to operate a Government-owned motor vehicle or his current authorization is renewed.
- Items checked on this form or otherwise available do not warrant referral for medical examination because of the following facts:

Signature of Designated Official	Date
----------------------------------	------

Figure 1-35.—Physical Fitness Inquiry for Motor Vehicle Operators, Standard Form 47.

examiner reviews and evaluates this form and other available information regarding the physical condition of the applicant and determines if a physical examination is required. Operators must have no physical defects or emotional instability that render them a hazard to themselves or others. The medical department conducts all physical examinations of applicants referred by the licensing examiner, and the results are recorded in the appropriate portion of the application form. The SF-47 is retained in the applicant file and replaced with a new one each time the license is renewed or upon request of the license examiner. Physical examinations are required for operators assigned to transport explosives.

LICENSE TEST

Applicants must pass a written examination before taking the performance qualification tests. The written test is based on traffic laws and regulations, accident reporting procedures, operator's maintenance responsibilities, safe driving practices, and the characteristics and limitations of the types of equipment for which the test is being given. Information particular to a piece of equipment is obtained from the operator's manual located in the Technical Library.

Written examination questions are prepared by the license examiner and are approved by the equipment officer and at least two written tests should be developed for each type of equipment. Written examinations, blank license, and answer sheets are stored in a secure location under lock and key. Numerous sample written tests for construction and weight-handling equipment are contained in the *Testing and Licensing of Construction Equipment Operators*, NAVFAC P-306. Applicants should study the operator's manual when preparing for written and performance examinations.

Examinations and tests for military personnel applying for a license to operate general-purpose vehicles up to 10,000 pounds GVW is normally waived if the applicant possesses a valid state operator's license for the type vehicle involved.

Performance Qualification Tests

All performance qualification tests (excluding cranes) must be given by the license examiner. All applicants who pass the written test must successfully pass an operational performance or road test and perform pre and post operational operator maintenance,

as outlined in the operator's manual. The performance qualification test enables a qualified examiner to evaluate the operating skills of each applicant. The examiner must terminate any performance test that becomes hazardous or when an applicant demonstrates a lack of skill, undue nervousness, speeding, inattentiveness, or other unfavorable actions. Personnel failing to qualify for a license should not be reexamined until after further training or instruction. The specific reason for failure is noted on the application and filed in the license file of the applicant.

Automotive Tests

Applicants for an OF-346 must pass a locally created driver skill test before being given a road test to determine their reactions under varying traffic conditions. The road test is administered in the largest capacity vehicle for which the license is to be issued. A locally devised checklist that reflects the requirements for the local conditions is used for the evaluation.

Materials-Handling Equipment Tests

Applicants for the materials-handling equipment (MHE) license are operationally tested and scored as prescribed in *Storage and Materials Handling*, DODINST 4145.19-R-1. This publication contains sample MHE test questions.

Construction Equipment Tests

Applicants for a NAVFAC 11260/2 license must be familiar with the standard Navy hand signals before taking a performance qualification test. A wide variety of construction and weight-handling equipment is used by the Navy. For this reason, standard Navy-wide performance qualification tests are not practical; therefore, the local examiner must prepare such operational tests as required. Numerous samples of operational tests are contained in the NAVFAC P-306.

LICENSE FORMS

After an applicant satisfactorily completes all the required tests, the examiner issues a license that lists each type of vehicle the license holder is authorized to operate. Any restrictions imposed on the license are also listed.

U.S. Government Motor Vehicle Operator's Identification Card, OF-346

The OF-346 is the license required for automotive motor vehicles and material-handling equipment. Possession of a valid state operator's license is not required for the issuance of an OF-346 to military personnel on active duty. However, an OF-346 and a valid state driver's license are required to operate government-owned or rented vehicles or equipment off base in Alaska, Massachusetts, Nebraska, Missouri, New Hampshire, New Jersey, New York, Connecticut, Vermont, and the District of Columbia.

A properly completed and valid OF-346 must have the following entries:

1. **Card number:** A two-part sequential number that is the actual license number. The first part of the number is the activity number or unit designation of the original license issuing activity. The second part of the number is the appropriate sequential number in order of issue. Example: NMCB-3 license number 88 becomes 3-88; a 31ST NCR license number becomes 31-88. This number is indicated on the operator's record, NAVFAC 11240/10, or NAVFAC 11260/3, Construction Equipment Operator License Record (fig. 1-36). The license examiner maintains a chronological record of all licenses issued.
2. **Restrictions:** Physical limitations and restrictions. Typical notations are glasses, daytime, hearing aid, or learner.
3. **Types of vehicle or equipment:** A description of equipment the operator is qualified to operate. Each separate item does not have to be listed; use notations like trucks through 1 1/4 tons, tractor and trailer through 10 tons, and so forth.
4. **Capacity:** See Item 3.
5. **Qualifying official:** Signature of examiner.
6. **Other records:** This section is used for a type of license that requires specific notation. Examples are as follows: ambulance, fire truck, ammunition and explosive ordnance vehicles, and avgas refuelers. This entry can also be used as a continuation for Items 3 and 4.

The OF-346 is valid for 3 years and may be renewed for additional periods of 3 years each. Remember, the OF-346 expires on the birth date of the operator.

Construction Equipment Operator License, NAVFAC 11260/2

The NAVFAC 11260/2 is the proper license for operating construction equipment. A complete and valid NAVFAC 11260/2 must have the following entries:

1. **Card number:** A two-part sequential number that is the actual license number. The first part of the number is the activity number or unit designation of the original license issuing activity. The second part of the number is the appropriate sequential number in order of issue, for example: NMCB-3 license number 88 becomes 3-88; a 31ST NCR license number becomes 31-88. This number is indicated on the operator's record, NAVFAC 11240/10 or NAVFAC 11260/3, Construction Equipment Operator License Record (fig. 1-36). The license examiner maintains a chronological record of all licenses issued.
2. **Date issued:** Abbreviated entries of the issuing date, month, and year.
3. **Date expired:** Abbreviated entries of the expiration date, month, and year. The NAVFAC 11260/2 is valid for 2 years and may be renewed for additional periods of 2 years each. The license expires on the birth date of the operator in odd or even years, consistent with the operator's year of birth. For example, if the birth date is 20 June 1960, the expiration dates are 20 June 1994 and 20 June 1996. The license expires on the birth date of the operator in odd or even years, consistent with the operator's year of birth. For example: If the birth date is 20 June 1960, the expiration dates are 20 June 1994, 20 June 1996, and so forth.
4. **Name of operator:** The operator's name, as contained in official personnel records.
5. **Equipment type:** Description of the basic units the operator is qualified to operate. Typical notations are front-end loader, dozer, grader, or excavator.
6. **Size and capacity:** Make and model of equipment written as the equipment type. Typical notations are JD670, D8 CAT, D7 CAT, Bantam, Gradall, 515 Dresser, and so forth.
7. **Attachment:** Description of the attachment the operator is qualified to operate. Typical notations are backhoe, forks, bucket, blade, winch, ripper, or all attachments. This entry can also be used to denote gas- or diesel-powered equipment.

CONSTRUCTION EQUIPMENT OPERATOR LICENSE RECORD
 NAVFAC 11260/3 (Rev. 3-78)
 S/N 0106-LF-0126015

LICENSE NO. N62688-0000-6-30

NAME E. J. McGEE

DATE OF BIRTH 6-19-30

VISION		SPECIAL REQUIREMENTS FOR HEARING	
NONE	HEARING AID REQUIRED	OTHER	N/A

EQUIPMENT LICENSED TO OPERATE

LICENSING DATA

EQUIPMENT TYPE DATA		LICENSING DATA							
BASIC UNIT	ATTACHMENT	TYPE OF CONTROL	ISSUING ACTIVITY	EXAMINER	DATE ISSUED	DATE REVOKED	EXPIRATION DATE	RENEWAL DATE	DATE OF PHYSICAL EXAM.
FRONT LOADER	BUCKET	HYD	PWD NAVSTA NORFOLK	E. H. BARNES	7-20-76	6-19-78	7-20-78	6-19-78	6-12-78
DOZER	BLADE	HYD	PWD NAVSTA NORFOLK	E. H. BARNES	7-20-76		7-20-78	6-19-78	6-12-78
GRADER	ALL	HYD	PWD NAVSTA NORFOLK	E. H. BARNES	7-20-76		7-20-78	6-19-78	6-12-78
MOBILE CRANE 20 TON	HOOK BLOCK CLAM SHELL	HYD	PWD NAVSTA NORFOLK	E. H. BARNES	8-22-78		6-19-80		8-22-78

NOTE: INFORMATION ON THIS FORM IS SUBJECT TO SAFEGUARD AND DISCLOSURE CONDITIONS OF THE PRIVACY ACT OF 1974.
 U.S. Government Printing Office: 1983-603-010/688 2-1

Figure 1-36.—Construction Equipment Operator License Record, NAVFAC 11260/3.

8. Types of controls: On the equipment where control types are variable, enter hydraulic (H), electrical (E), and mechanical (M), as appropriate.

The licensing examiner maintains a tickler file of each operator's license expiration date. License renewal action should start approximately 90 days before the expiration date. The examiner also maintains an additional history record for construction operators on the NAVFAC 11260/3, Construction Equipment Operator License Record (fig. 1-36). The NAVFAC 11260/3 is retained in the license file of the operator.

LICENSE UPGRADING

Applications for upgrading a license to larger or different types of equipment are submitted in the same manner as an original request. Normally, the only test required for upgrading a license is an operator qualifying test for the type and capacity of the equipment to which the license is being upgraded. The license examiner signs the upgraded entry on the OF-346 or NAVFAC 11260/2 and updates the license file of the applicant.

LICENSE RENEWAL

License renewal is dependent on the license examiner, provided the renewal date is prior to the present license expiration date. The examiner determines if the operator still meets the requirements for the license being renewed. When the examiner has any doubt, the operator should be re-examined in the appropriate area or areas. Operators whose license expire before being renewed must be re-examined as a new applicant. Operator licenses that expire while personnel are assigned to a combat zone are automatically extended until assignment to a noncombat area.

LICENSE CANCELLATION

When a person leaves the service, all government licenses are canceled. Personnel may retain the license provided it is stamped "Canceled Due to Separation" across the front, initialed, and dated by the examiner.

LICENSE SUSPENSION AND REVOCATION

Commanding officers, officers in charge, and equipment officers may revoke or suspend an

operator's license at any time for cause. All revoked or suspended licenses should be returned to the license office without delay. Supporting justification and records for license suspensions and revocation should be kept in the license file of the operator.

The equipment officer conducts traffic court for traffic violations under the guidelines set forth by the command. The license examiner is present at all traffic court hearings and documents traffic court results in the license file of the individual.

When a construction operator's license is revoked, the examiner should make a notation in the Date Revoked column of NAVFAC 11260/3. Revoked licenses are not restored until the operator is fully qualified through reevaluation and reexamination. A request for reexamination of an operator whose license has been suspended or revoked should specifically outline the incidents leading to the suspension or revocation, so special training emphasis can be placed on that portion of the reexamination. Licenses are usually suspended for a designated time period with no waiting requirement for reinstatement.

LOST OR MUTILATED LICENSES

Lost, destroyed, or mutilated licenses are replaced upon verification of the original license issued. This verification can be accomplished by referring to the License Application Form filed in the appropriate personnel service record or from the license file of the applicant.

LICENSE FILES

License files for the operator are maintained by the license examiner and stored in a secured location under lock and key. Each member in the command who possesses an OF-346 or NAVFAC 11260/2 must have a license file. The license file consists of the NAVFAC 11240/10, SF-47, NAVFAC 11260/1, expired licenses, and other related licensing matters.

PERSONNEL OFFICE

The personnel office must include the license examiner in the check-in or check-out process of personnel in the command. Personnel who check in a command possessing the OF-346 or a NAVFAC 11260/2 must have the NAVFAC 11240/10 and the NAVFAC 11260/3 pulled from their service record and forwarded to the license examiner for processing. According to NAVMILPERSCOM ART 5030200,

when personnel check out of a command, the examiner must ensure the NAVFAC 11260/3 and the NAVFAC 11240/10 are forwarded for filing in the person's service record before transfer.

TRAINING PROGRAM

Poor equipment operating practices and habits cause mishaps and premature equipment breakdowns. An effective training program on the procedures for issuing or renewing a license reduces poor practices, mishaps, and habits. In addition to being supervised by the license examiner, this training program must be supervised by the equipment officer, safety officer, the applicant's supervisor, and other qualified operators.

Training License

Equipment training licenses are issued to personnel who meet all the required physical and mental qualifications to be licensed but need more on-the-job training on a piece of equipment. The training license expiration date should not exceed 30 days from the date of issue and must have the word *learner* stamped on the face. The license is only valid when the trainee is accompanied by a qualified instructor or when the trainee is using Navy equipment in a controlled training environment. Training licenses are not required to operate Navy equipment as part of formalized training programs given at the Naval Construction Training Centers.

Course of Instruction

In addition to learning how to operate equipment, a trainee is required to study a course of instruction. This locally prepared course must include, but need not be limited to, the following subjects:

1. Fundamentals of vehicle operation, including the functions and proper use of major assemblies and attachments and equipment limitations.
2. Operator responsibilities before, during, and after operation maintenance.
3. Safety precautions and accident prevention through safe driving practices.
4. Traffic laws, rules and regulations, hand signals, traffic signs, signals, and markings.

5. Accident reporting procedures and other forms and reports that an operator is responsible for completing.

MISHAP INVESTIGATIONS

Usually, the license examiner is assigned the responsibilities of the motor vehicle mishap investigator for the command assigned. The *Mishap Investigation, Reporting and Record Keeping*, DODINST 6055.7, states all accidents involving DoD motor vehicles, including rented CESE, are investigated to determine the cause and circumstances.

Thorough investigations of all accidents are made and evidence documented promptly for use in the event a claim is filed against the government. Accidents that appear trivial may eventually result in legal suits. Therefore, mishap investigators must follow the mishap investigation guidelines set forth in the OPNAVINST 5102.1 latest edition.

A mishap investigator must work closely with the command safety chief to develop safety and accident prevention programs for the command. These programs include the safe operation of CESE, provisions for the mandatory use of seat belts, and the prohibition against smoking in vehicles. They also perform joint investigations of serious mishaps that include injury or fatalities.

According to OPNAVINST 5102.1, government-owned or leased motor vehicles that involve a fatality, injury, or sustain a total damage of \$2,000 or more require a NAVGRAM sent to the Naval Safety Center. The command must send the NAVGRAM within 30 days of the mishap to the Commander, Naval Safety Center, Naval Air Station, Norfolk, Virginia. On-duty motor vehicle accidents resulting in five or more persons being hospitalized is reported by priority message or telephone.

ROADMASTER

In most cases, the license examiner is assigned to serve as the battalion roadmaster. The roadmaster assures the safe operation of the battalion's equipment and enforces regulations as directed by the Alfa company commander. Additionally, the roadmaster should escort oversized loads and check prospective routes of travel for obstructions.

CHAPTER 2

AIR DETACHMENT EQUIPMENT SUPERVISOR

An air detachment (air det), as stated in the *U.S. Naval Mobile Construction Battalion (NMCB) Doctrine and Policy Governing*, OPNAVINST 5450.46, is part of a Naval Mobile Construction Battalion (NMCB) organization and is capable of deploying within 48 hours of notification. The mission of an air det is to provide contingency support for the Navy, Marine Corps, and other forces, and perform and participate in disaster recovery operations and field exercises (FEX). An air det has approximately 90 personnel assigned and contains airlift supplies, tools, and civil engineer support equipment (CESE) that can be airlifted to perform both horizontal and vertical construction. An air det must be self-sufficient for 30 days (600 construction hours) in all aspects, except that ammunition, rations, and POL are limited. When provided logistic support, an air det can operate independently of an NMCB for an indefinite period.

AIR DETACHMENT EQUIPMENT SUPERVISOR RESPONSIBILITIES

The type and amount of CESE embarked with an air det depends on the construction tasking and duration of the assigned mission. The officer in charge (OIC) of an air det is the equipment officer for the CESE assigned to the det; however, the daily management of CESE is the responsibility of the senior Alfa company rating assigned to the air det. This chapter presents the basic information required for you to perform your duties effectively when resigned as the air detachment equipment supervisor.

CREW ASSIGNMENTS

Personnel are assigned to the air det by the Battalion Operations Department, using the basic guidelines provided in the *Naval Construction Force Embarkation Manual*, COMSECOND/COMTHIRDNCBINST 3120.1 series. The ratings and number of personnel assigned to the air det are governed by the tasking of the mission.

The air det is organized into three platoons: an equipment platoon, a support platoon, and a construction (Builder) platoon.

The equipment platoon supervisor organizes the platoon and assigns military and job-related responsibilities. Job assignments are organized similar to an Alfa company operation. The job

assignments are as follows: dispatcher, yard boss, collateral equipage/attachment custodian, license examiner, maintenance supervisor, shop supervisor, PM/cost control clerk, DTO clerk, technical librarian, floor mechanics, mechanic field crews, and project crews. Personnel may be assigned two or three job responsibilities, depending on the size of the platoon. These responsibilities are contained in *Equipment Management*, COMSECOND/COMTHIRDNCBINST 11200.1 series, and are also covered in chapter 1 of this TRAMAN.

EQUIPMENT PLATOON ADMINISTRATION READINESS

Equipment platoon administration readiness is the process of storing at least a 30-day supply of all required forms and office supplies in a mount-out box or location. This allows you to manage the operations of an equipment platoon effectively in the event of an air det mount-out. The air det dispatcher, license examiner, and maintenance supervisor should store the following forms:

1. Dispatcher's Log, NAVFAC9-11240/2
2. Operator's Inspection Guide and Trouble Report, NAVFAC 9-11240/13
3. Operator's Daily PM Report, NAVFAC 9-11260/4
4. Motor Equipment Utilization Record, DD Form 1970
5. Collateral Custody Record Card, COMSECOND/COMTHIRDNCB 60 Form
6. NAVSUP Form 1250
7. PM Record Card, NAVFAC 11240/6
8. Equipment Repair Order, NAVFAC 11200/41
9. Equipment Repair Order Continuation Sheet, NAVFAC 11200/41A
10. Operator's Identification Card, OF-346
11. Construction Equipment Operator's License, NAVFAC 11260/2
12. Application for Vehicle Operator's Identification Card, NAVFAC 11240/10

13. Application for Construction Equipment Operator's license, NAVFAC 11260/1
14. Physical Fitness Inquiry for Motor Vehicle Operators, SF-47
15. Construction Equipment Operator License Record NAVFAC 11260/3
16. Miscellaneous office supplies

Do not wait for notification of the air det to mount-out to start acquiring the required forms. If you do, you may find the dispatcher, license examiner, mechanic shop, or the supply department not having enough forms in stock to supply the needs for the daily operations of the equipment platoon.

TABLE OF ALLOWANCE (TOA)

The table of allowance (TOA) outfits the Naval Mobile Construction Battalion (NMCB) with the tools and equipment to perform construction operations under contingency conditions for 90 days (1,800 construction hours) without resupply; however, fuel and subsistence are limited to 15 days support, and construction materials are not part of the TOA. The area commander/project sponsor requiring the utilization of Seabees is responsible for

the procurement and shipment of construction materials.

The Civil Engineer Support Office (CESO), Port Hueneme, California, is the system manager responsible for maintaining the Naval Construction Force (NCF) TOAs. CESO develops new allowances as directed by COMNAVFACENGCOM and collects field recommendations for revisions to existing TOAs. The TOA represents the best selection of tools and supplies needed to provide general construction capabilities. However, the TOA is not capable of meeting every operational requirement. When an assigned project requires tools or equipment in excess of the capability of the unit, the allowance must be supplemented by augmentation.

An NMCB TOA is divided into three echelons: the air detachment (TA41), air echelon (TA31) minus the air det, and sea echelon (TA22). The echelons are based on anticipated prioritization of personnel, material, equipment, and the availability of airlift versus sealift support.

The equipment platoon supervisor and the lead mechanic should review the TA41 and request the

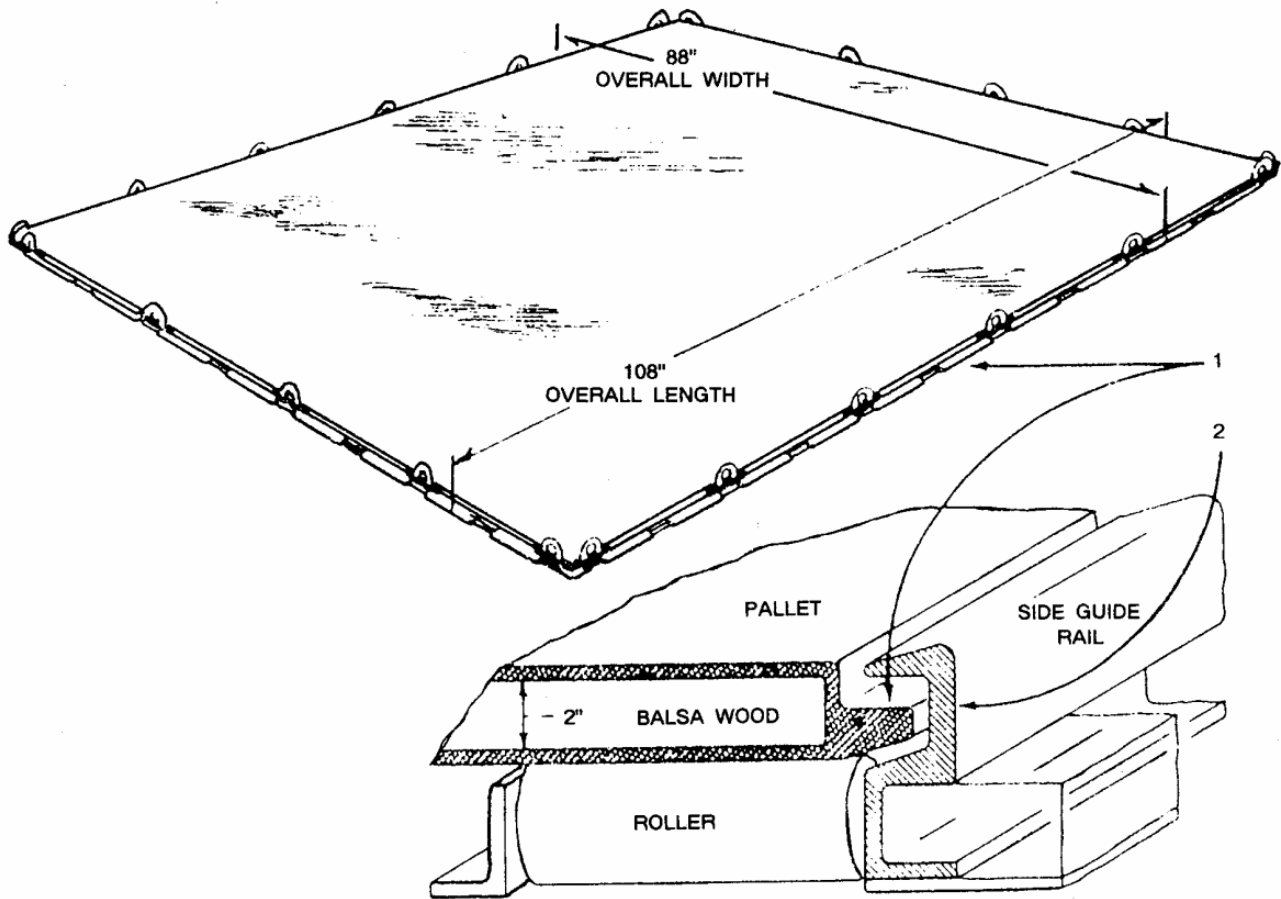

Figure 2-1.—Air Force 463L cargo pallet.

tools and supplies required to support the air det equipment platoon operation. Examples of these tools and supplies are as follows: the kit 80013, mechanic hand look for two men; kit 80031, metric support tools; kit 80057, tire service tools (small); kit 80107, lubrication equipment and accessories. Do not forget other important items, such as a bundle of rags; a hand-operated fuel/oil dispensing pump for 55-gallon drums (commonly known in the NCF as a "hurdy-gurdy"); 55-gallon drums for fuel, oil cans, rigging gear, jumper cables; and tools for the field maintenance truck; and tools to support any construction tasking. The request list is forwarded through the air det chain of command and reviewed and approved by the battalion staff.

The lead mechanic is responsible for coordinating with the maintenance supervisor when requesting the NAVSUP modifier code 96, "repair parts common"; NAVSUP modifier code 98, "O level repair parts peculiar"; and petroleum oil lubricant (POL) products.

Normally, The TA41 kits and supplies are stored in a supply warehouse. During the 48-hour mount-out, the requested kits and supplies are drawn out and staged at the marshaling area. **FOLLOW UP** on the requested tools and supplies throughout the mount-out period. Overlooked and forgotten items can hamper a well-planned air det operation.

CESE REQUIREMENTS

The basic CESE allowance for an air det is contained in the TA41; however, the air det-assigned CESE for your deployment site is listed in the Equipment TAB A The organic CESE in the TAB A is divided into three echelons: AD for air det, AE for air echelon, and SE for sea echelon. CESE with like equipment codes (ECs) but different echelon can be changed to meet the needs of the air det.

The amount of CESE and supplies required for a mission is controlled by the availability of airlift, sealift, or over-the-road support. This requires the air det to preplan and prioritize all tasking and request only the amount of resources needed to accomplish the mission successfully. The knowledge and expertise of the equipment platoon supervisor enhances the ability of the air det to identify and request the required CESE, supplies, and POL for the air det mission. When identifying CESE, you should consider the following: convoy capabilities, equipment specifications, parts support, equipment conditions, and equipment aircraft certification and certifiability. Prioritize the CESE, supplies, and POL requirements. This allows the embarkation office to prepare aircraft load plans to meet the needs of the air det. Material and CESE requirements are discussed and approved by the battalion staff.

OPERATOR ASSIGNMENTS

Once the CESE list has been established, the equipment platoon supervisor must assign operators and co-drivers. Operators must stand by their assigned CESE that has been prepared and staged at the marshaling area for the joint inspection (JI). They are also required to accompany the assigned CESE throughout the transport to the mission site.

The staging and marshaling area is where equipment and materials are received. CESE is inspected for cleanliness and fluid leaks, mobile loads are completed, vehicles are weighed and marked for center of balance, cargo is palletized on the Air Force 463L cargo pallets (fig. 2-1), and cargo and CESE are placed into a configuration (chalk) for each aircraft (fig. 2-2).

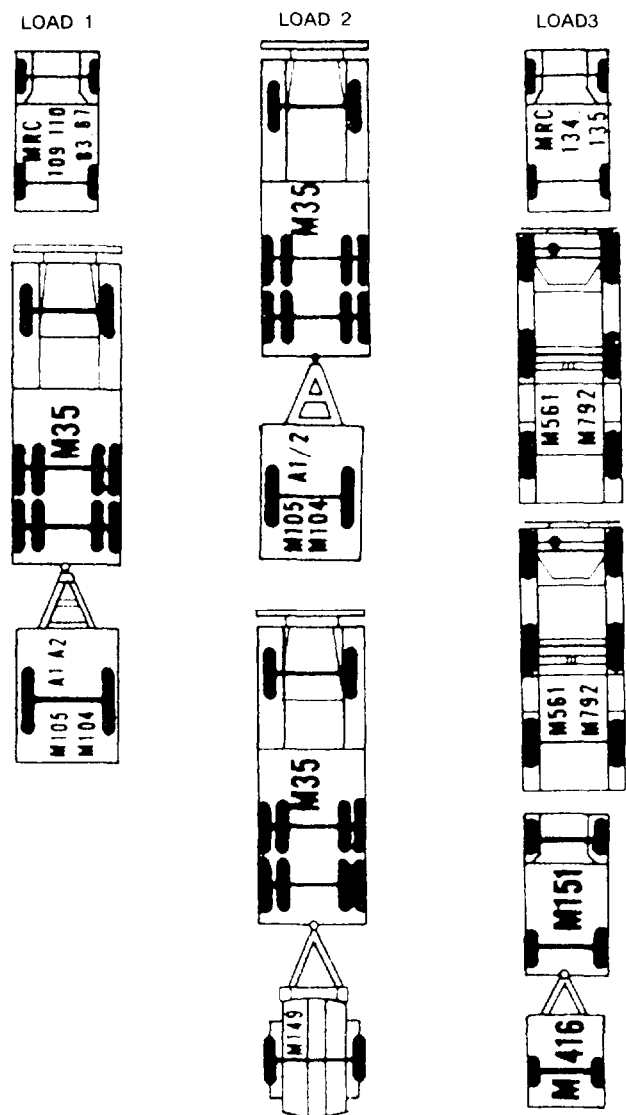

Figure 2-2.—Marshalling for C-130 and C-141 aircraft.

During the home-port period, a pre-JI is conducted before the JI by the battalion embarkation officer and the regiment embarkation staff from Port Hueneme, California, or Gulfport, Mississippi. When deployed overseas, the pre-JI is performed by COMSECOND/COMTHIRDNCB embarkation representatives. The pre-JI includes the inspection of all chalks of CESE, marriages and mobile loads of CESE, hazardous materials, and Special Handling Data/Certification (DD Form 1387-2) (fig. 2-3), and 463L pallet loads. The pre-JI allows the battalion time to correct any discrepancies before the main joint inspection (JI).

NOTE: Ensure members are licensed for CESE assigned. licenses can be checked during this inspection.

The JI is conducted by the battalion embarkation officer, regiment or COMSECOND/COMTHIRD-NCB representatives, and the combat cargo officer of a ship or, for aircraft, the Departure Airfield Control Element (DACE) in conjunction with the U.S. Air Force Airlift Control Element (ALCE). The joint inspection is recorded on the DD Form 2133 (fig. 2-4).

Information concerning the operations of the marshaling area or joint inspections are provided in the *MAC Affiliation Training Program Airlift Planners Course*, MAC pamphlet 50-13, and the *Naval Construction Force Embarkation Manual*,

COMSECOND/COMTHIRDNCBINST 3120.1 series.

CESE AND MATERIAL PREPARATION

Upon notification of the air det to mount-out, the battalion re-organizes and sets up a mount-out control center (MOCC). The MOCC is under the direction of the battalion executive officer. The MOCC controls, coordinates, and monitors the movement of all personnel, supplies, and equipment to the marshaling area. The MOCC and the embarkation staff control all aspects of an NMCB mount-out and serve as the coordinating center for all the companies and battalion staff.

During this period, the battalion is normally organized into 12-hour shifts. Alfa company is responsible for all CESE preparation. The flow of the CESE through Alfa company is similar to the BEEP flow chart listed in chapter 1. During this time period, the air det is usually involved in briefings, medical and dental checkups, administration office checkups, and personnel readiness inspections. However, YOU need to schedule time to communicate with Alfa company, and **FOLLOW UP** on the status of CESE requested. Remember, the battalion is preparing CESE and supplies for the air det that you will have to live with.

Embarking on an aircraft requires special loading procedures for several types of CESE assigned to the battalion TOA. These procedures are outlined in the

ITEM NOMENCLATURE Sodium Aluminate Solution Corrosive Material Corrosive		NET QUANTITY PER PACKAGE 1 Gal	TRANSPORTATION CONTROL NO. N0017102261904XXX		
		CONSIGNMENT GROSS WEIGHT 10 lbs	DESTINATION Washington Navy Yard DC		
SUPPLEMENTAL INFORMATION This shipment is within the limitations prescribed for passenger aircraft. Neutralizing agent 5% Acetic Acid			LOAD STORAGE/GROUP 20		
			FLASH POINT NA		
This is to certify that the above named materials are properly classified, described, packaged, marked and labeled, and are in proper condition for transportation according to the applicable regulations of the Dept of Transportation. THIS IS A MILITARY SHIPMENT! (Complete applicable blocks below)					
X	This shipment is within the limitations prescribed for PASSENGER AIRCRAFT: CARGO-ONLY AIRCRAFT (Delete nonapplicable aircraft)		ATA/IATA/IMCO REGULATIONS		
X	AFR 71-4, TM 38-250, NAVSUPPUB 505, MCO P4030.19, DLAM 4145.3, Paragraph 8-8a (2)		49 cfr	PARAGRAPH	EXEMPTION
	DOD 4500.32R (MILSTAMP)			173 7 (a)	DOT-E 7573
ADDRESS OF SHIPPER Address			TYPED NAME, SIGNATURE AND DATE Name and Date		
DD FORM 1387-2 1 MAY 79		PREVIOUS EDITION IS OBSOLETE		SPECIAL HANDLING DATA/CERTIFICATION	

Figure 2-3.—Special Handling Data/Certification, DD Form 1387-2.

JOINT AIRLIFT INSPECTION RECORD (See Instructions on Reverse Side)							PAGE 1 OF 1 PAGES											
1. UNIT BEING AIRLIFTED: 2/5 MAR			2. DEPARTURE AIRFIELD: LINDBERGH FIELD, S.D., CA			3. DATE (Day, Month, Year): 10 Oct 85												
4. TYPE, MODEL, SERIES, AIRCRAFT AND SERIAL NO: C 141B			5. MISSION NUMBER: GK S-109		6. LOAD CHECK NO: 3		7. TIME COMPLETED: 17:52											
8. ALCY ACT: 63 MAW																		
LEGEND (Mark blocks after each item as follows)			INCREMENT SERIAL BUMPER NUMBER AND TYPE															
✓ = SATISFACTORY X = UNSATISFACTORY IF NOT APPLICABLE - LEAVE BLANK			TRK	TEL	MC TRK	MC TEL	MC GUN	MC TRK	MC GOAT	MC G.TRL	PLT							
			HQ13	HQ13T	3306	4712	1114	4010	7277	3606	13							
A. DOCUMENTATION																		
9. MANIFESTS / NUMBER OF COPIES			✓	✓	✓	✓	✓	✓	✓	✓	✓	✓	✓	✓	✓	✓	✓	✓
10. DD FORM 1387-2 (As required)			✓	✓	✓	✓	✓	✓	✓	✓	✓	✓	✓	✓	✓	✓	✓	✓
11. HAZARDOUS CARGO COMPATIBILITY			✓	✓	✓	✓	✓	✓	✓	✓	✓	✓	✓	✓	✓	✓	✓	✓
12. LOAD LISTS / CUSTODIAN TRANSFER FORMS			✓	✓	✓	✓	✓	✓	✓	✓	✓	✓	✓	✓	✓	✓	✓	✓
B. VEHICLES / NON-POWERED EQUIPMENT																		
13. CLEAN			✓	✓	✓	✓	✓	✓	✓	✓	✓	✓	✓	✓	✓	✓	✓	✓
14. FLUID LEAKS			✓	✓	✓	✓	✓	✓	✓	✓	✓	✓	✓	✓	✓	✓	✓	✓
15. MECHANICAL CONDITION																		
a. ENGINE RUNS			✓	✓	✓	✓	✓	✓	✓	✓	✓	✓	✓	✓	✓	✓	✓	✓
b. BRAKES OPERATIONAL			✓	✓	✓	✓	✓	✓	✓	✓	✓	✓	✓	✓	✓	✓	✓	✓
16. BATTERY																		
a. SECURE - NO LEAKS			✓	✓	✓	✓	✓	✓	✓	✓	✓	✓	✓	✓	✓	✓	✓	✓
b. IF DISCONNECTED - POST / CABLES TAPED			✓	✓	✓	✓	✓	✓	✓	✓	✓	✓	✓	✓	✓	✓	✓	✓
17. FUEL TANK(S)																		
a. ONE-HALF (1/2) TANK			✓	✓	✓	✓	✓	✓	✓	✓	✓	✓	✓	✓	✓	✓	✓	✓
b. ONE-FOURTH (1/4) TANK			✓	✓	✓	✓	✓	✓	✓	✓	✓	✓	✓	✓	✓	✓	✓	✓
c. DRAINED (As required)			✓	✓	✓	✓	✓	✓	✓	✓	✓	✓	✓	✓	✓	✓	✓	✓
d. FUEL TANK CAPS INSTALLED			✓	✓	✓	✓	✓	✓	✓	✓	✓	✓	✓	✓	✓	✓	✓	✓
18. JERRY CANS (Secure, Fuel Level, Seals)			✓	✓	✓	✓	✓	✓	✓	✓	✓	✓	✓	✓	✓	✓	✓	✓
19. DIMENSIONS (Fits A/C Profile or Contour)			✓	✓	✓	✓	✓	✓	✓	✓	✓	✓	✓	✓	✓	✓	✓	✓
20. CENTER OF BALANCE (Both Sides)			✓	✓	✓	✓	✓	✓	✓	✓	✓	✓	✓	✓	✓	✓	✓	✓
21. SCALE WEIGHT (Both Sides)			✓	✓	✓	✓	✓	✓	✓	✓	✓	✓	✓	✓	✓	✓	✓	✓
22. AXLE WEIGHTS (Both Sides)			✓	✓	✓	✓	✓	✓	✓	✓	✓	✓	✓	✓	✓	✓	✓	✓
23. TIEDOWN PINS (Serviceable)			✓	✓	✓	✓	✓	✓	✓	✓	✓	✓	✓	✓	✓	✓	✓	✓
24. PINTLE HOOKS / CLEVIS																		
a. SERVICEABLE			✓	✓	✓	✓	✓	✓	✓	✓	✓	✓	✓	✓	✓	✓	✓	✓
b. SAFETY PIN ATTACHED			✓	✓	✓	✓	✓	✓	✓	✓	✓	✓	✓	✓	✓	✓	✓	✓
25. VEHICLE EQUIPMENT SECURE (Tools, tires, antennas, etc)			✓	✓	✓	✓	✓	✓	✓	✓	✓	✓	✓	✓	✓	✓	✓	✓
26. LOX / NITROGEN CART (Vent Kit)			✓	✓	✓	✓	✓	✓	✓	✓	✓	✓	✓	✓	✓	✓	✓	✓
27. TIRE PRESSURE			✓	✓	✓	✓	✓	✓	✓	✓	✓	✓	✓	✓	✓	✓	✓	✓
28. SHORING (Rolling, Parking, Sleeper)			✓	✓	✓	✓	✓	✓	✓	✓	✓	✓	✓	✓	✓	✓	✓	✓
29. ACCOMPANYING LOAD																		
a. WITHIN VEHICLE RATED CAPACITY			✓	✓	✓	✓	✓	✓	✓	✓	✓	✓	✓	✓	✓	✓	✓	✓
b. SECURE TO VEHICLE			✓	✓	✓	✓	✓	✓	✓	✓	✓	✓	✓	✓	✓	✓	✓	✓
C. PALLETS																		
30. CLEAN			✓	✓	✓	✓	✓	✓	✓	✓	✓	✓	✓	✓	✓	✓	✓	✓
31. SCALE WEIGHT (88 inch Side)			✓	✓	✓	✓	✓	✓	✓	✓	✓	✓	✓	✓	✓	✓	✓	✓
32. DIMENSIONS (Fits A/C Profile or Contour)			✓	✓	✓	✓	✓	✓	✓	✓	✓	✓	✓	✓	✓	✓	✓	✓
33. CARGO PROPERLY SECURED																		
a. NETTED			✓	✓	✓	✓	✓	✓	✓	✓	✓	✓	✓	✓	✓	✓	✓	✓
b. CHAINED			✓	✓	✓	✓	✓	✓	✓	✓	✓	✓	✓	✓	✓	✓	✓	✓
34. DUNNAGE (3 Pcs Per Pallet)			✓	✓	✓	✓	✓	✓	✓	✓	✓	✓	✓	✓	✓	✓	✓	✓
D. HELICOPTERS (Flyaway)																		
35. BATTERY (Disconnected/Taped)			✓	✓	✓	✓	✓	✓	✓	✓	✓	✓	✓	✓	✓	✓	✓	✓
36. FUEL QUANTITY (Gallons)			✓	✓	✓	✓	✓	✓	✓	✓	✓	✓	✓	✓	✓	✓	✓	✓
37. CENTER OF BALANCE (Both Sides)			✓	✓	✓	✓	✓	✓	✓	✓	✓	✓	✓	✓	✓	✓	✓	✓
38. SCALE WEIGHT (Both Sides)			✓	✓	✓	✓	✓	✓	✓	✓	✓	✓	✓	✓	✓	✓	✓	✓
39. SHORING (Rolling, Parking)			✓	✓	✓	✓	✓	✓	✓	✓	✓	✓	✓	✓	✓	✓	✓	✓
40. SPECIAL LOADING EQUIPMENT																		
41. REMARKS																		
The above listed vehicles / non-powered equipment have been inspected for proper shipping configuration in accordance with Chapter 3, AFR 71-4, TM 38-250 / NAVSUP PUB 505 (REV) / MCO P4030 19D / DLAM 4145 3																		
42. TRANSPORTER FORCE INSPECTOR (Signature, Rank, Unit of Assignment)			43. TRUCKER/ATA/ATA FORCE INSPECTOR (Signature, Rank, Unit of Assignment)															
Walter E. Walden, MG4SGT, 1MALCV			James A. Bragler, 1st, 63ARS															

DD Form 2133, NOV 86

Previous editions are obsolete

Figure 2-4.—Joint Airlift Inspection Record, DD Form 2133.

Naval Construction Force Embarkation Manual, COMSECOND/COMTHIRDNCBINST 3120.1 series. Alfa company is responsible for following these procedures that include the following: the removal of dump truck headache racks, equipment exhaust stacks, dozer blades, counterweights, and equipment roll over protective structure (ROPS). Also, the fuel tank of a vehicle to be embarked by airlift must be between one-fourth and three-fourths full; however, when the vehicle has to be placed on the ramp inside the aircraft, the fuel tank should never be more than one-third full. Accomplishment of these procedures is a major area of responsibility for the air det equipment platoon; therefore, make sure you know where Alfa company placed the bolts, nuts, and parts for the disassembled equipment because the air det will be required to reassemble these items on site.

After the CESE is cleaned, inspected, and serviced by Alfa company, the dispatcher notifies the MOCC that the CESE is ready to be transferred to the Weighing and Marking station.

WEIGHING AND MARKING

To plan an airlift and to break down loads for individual aircraft correctly, you must determine the weights and center of balance (C/B) of the two main divisions: vehicles and general cargo.

The weight and center of balance of vehicles are determined with secondary loads (mobile loads) mounted. Mobile loads are items of baggage or cargo transported in truck beds and trailers that must be

included in the total weight of a vehicle. To determine the center of balance (C/B) on a vehicle, the 20th Naval Construction Regiment Embarkation Staff (R23), Gulfport, Mississippi, recommends the following procedures:

Step 1. Establish the reference datum line (RDL). The RDL is the farthest forward point of a vehicle.

Step 2. Measure distance 1 (D1). D1 is the measurement in inches from the RDL to the center line of the front axle.

Step 3. Measure distance 2 (D2). D2 is the measurement in inches from the RDL to the center line of the intermediate axle or rear axle.

NOTE: The distance 2 measurement location for vehicles with tandem axles is measured from the RDL to the trunnion.

Step 4. Measure distance 3 (D3). D3 is the measurement in inches from the RDL to the center line of the rear axle. This step is performed on vehicles that have three or more axles and on towed vehicles that will remain married (attached) to a vehicle when loaded on the aircraft. The axles on a towed vehicle will become D4, D5, and so forth (fig. 2-5).

To perform Steps 5, 6, and 7, drive the vehicle onto portable scales (fig. 2-6) placed under the tires on each axle.

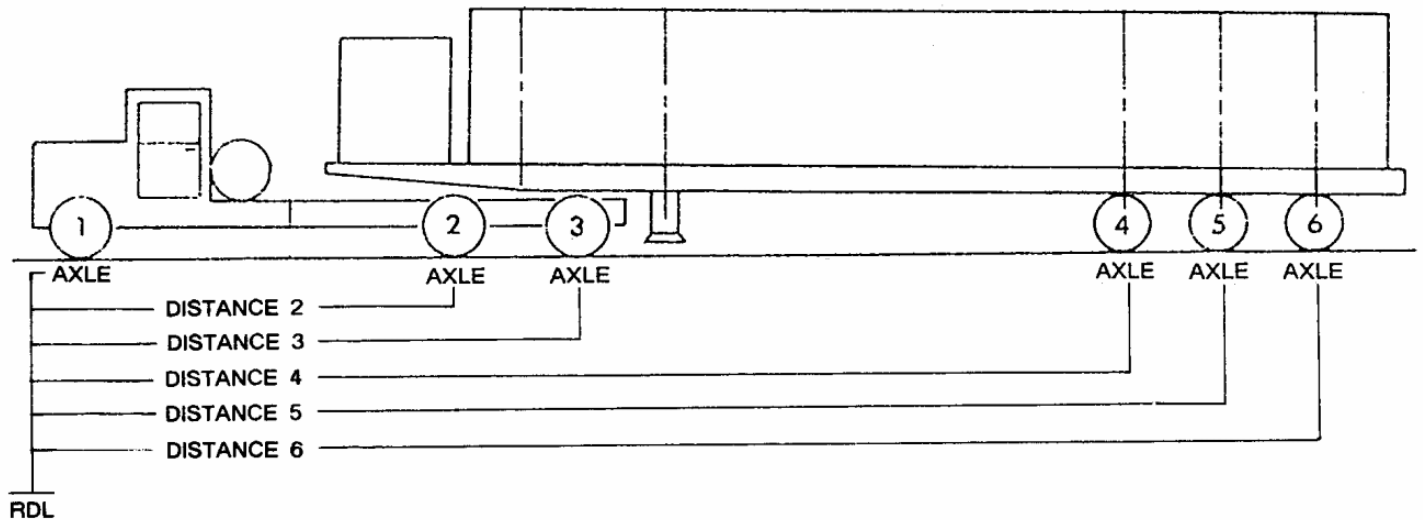

Figure 2-5.—CESE distance measurement locations.

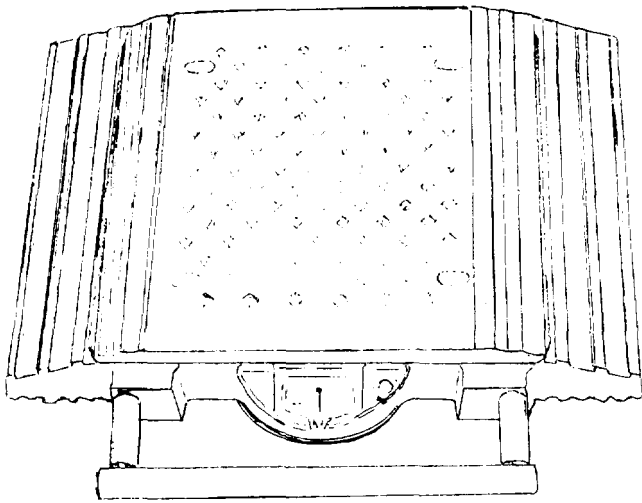

Figure 2-6.-Portable scales.

Step 5. Determine the forward axle weight (FAW). The FAW is the total weight reading of the scales under each front tire. Example: The left front tire scale reads 3,000 pounds, and the right front tire scale reads 3,000 pounds, and the FAW equals 6,000 pounds. This "FAW" is written (FAW 6,000) on a piece of weather-resistant material, such as duct tape, with a grease pencil, and attached to the vehicle fender above the axle. Remember, this tape must be

removed upon arrival at the site to avoid the removal of the paint on the vehicle.

Step 6. Determine the intermediate axle weight (IAW). The IAW is the total weight reading of the scales under the intermediate tires. Follow the procedures for Step 5 and label the reading as "IAW" on the masking tape. Remember, the IAW is the weight readings of both scales added together and recorded in pounds.

Step 7. Determine the rear axle weight (RAW). The RAW is the total weight reading of the scales under the rear tires. Follow the procedures for Step 5 and label the reading as "RAW" on the masking tape. Remember, the RAW is the weight readings of both scales added together and recorded in pounds.

NOTE: The RAW for vehicles with tandem axles is the weight of the IAW and the RAW added together and labeled above the trunnion (fig. 2-7).

Step 8. Compute moment 1 (M1). The formula for M 1 is distance 1 times the forward axle weight or $D1 \times FAW = M1$.

Step 9. Compute moment 2 (M2). The formula for M2 is distance 2 times the intermediate axle weight or $D2 \times IAW = M2$

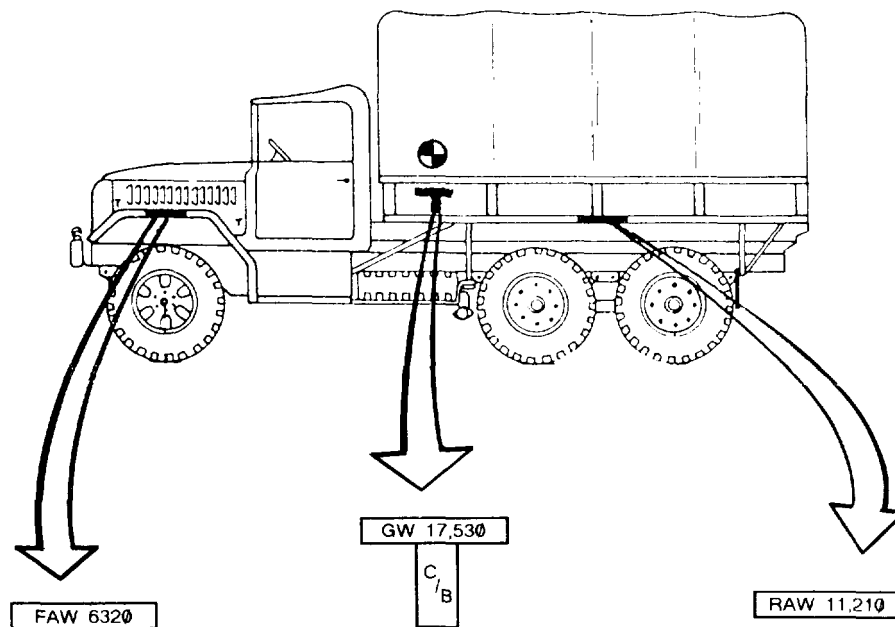

Figure 2-7.—Marking procedures.

TO DETERMINE CENTER OF BALANCE
 DRIVE VEHICLE ONTO WOODEN BEAM
 UNTIL IT BALANCES

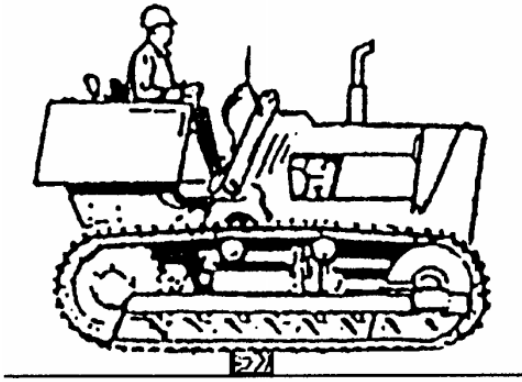

Figure 2-8.—Weight and balance of tracked vehicle.

Step 10. Compute moment 3 (M3). The formula for M3 is distance 3 times the rear axle weight or $D3 \times RAW = M3$.

Step 11. Compute the gross vehicle weight (GVW). The formula for GVW is $FAW + IAW + RAW = GVW$.

Step 12. Determine the total moment (TM). TM is determined by adding all the moments together. The formula is $M1 + M2 + M3 = TM$.

Step 13. Compute the center of balance (C/B) of the vehicle. This is done by dividing the GVW into the total moment, which provides the C/B value in inches.

Step 14. Locate the center of balance (C/B). The C/B is located by measuring from the RDL the number of inches computed in Step 13. At that point, label on the side of the vehicle with masking tape, a letter "T." The horizontal portion of the tape is labeled "GVW" plus the weight. The vertical portion of the tape is labeled "C/B" and the distance in inches measured from the RDL (fig. 2-7).

Although there are other procedures used to compute the center of balance for vehicles, the above procedures must be followed when you use the computer aided load manifest (CALM) computer program currently used in the NCF.

To find the C/B of a track vehicle (dozer), drive the vehicle onto a wooden beam until it balances (fig. 2-8). The weight of a track vehicle is determined

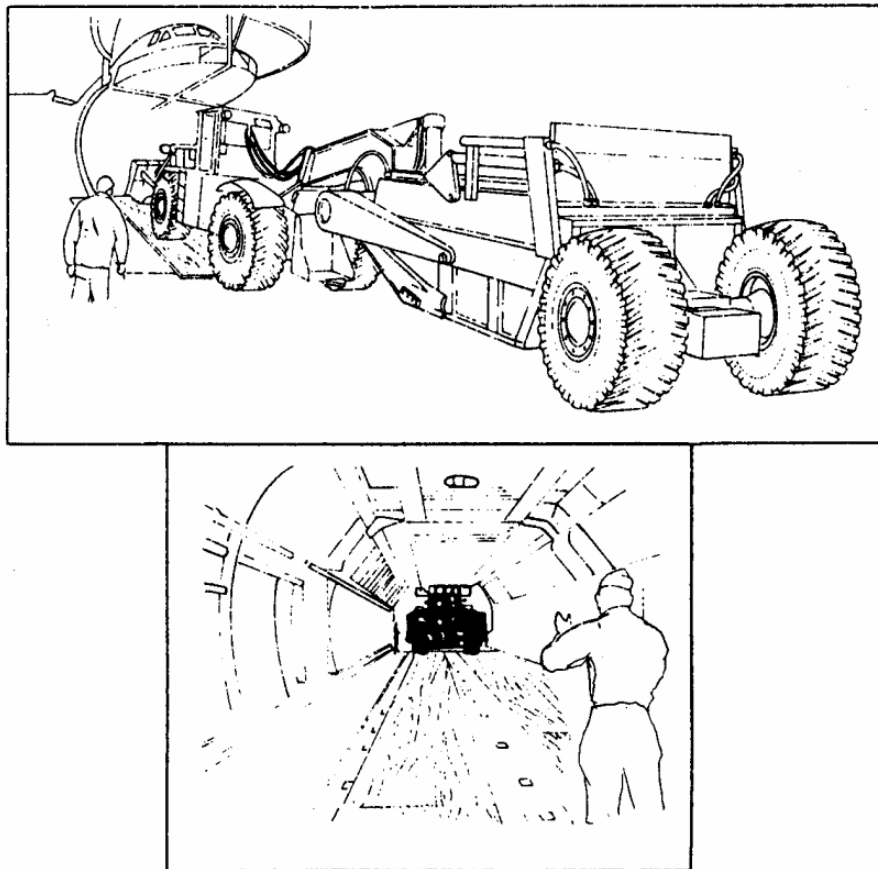

Figure 2-9.-Roller shoring.

by laying wood on top of the scales and driving the dozer onto the wood. The sum of the weight of the scales provides the GVW.

Once all the weights have been computed, they are marked on both sides of the vehicle and are annotated on the manifest list. The vehicle is then staged on the scheduled chalk.

Members of the air det must be highly qualified in both vehicle and cargo weighing and marking procedures because upon completion of the mission, the air det is responsible for mounting itself out to return home.

SHORING

Shoring is required for any type of equipment or cargo that can create metal-to-metal contact

aboard the aircraft. Shoring for individual equipment is usually precut, banded, and marked with the USN number of the equipment and accompanies the piece of equipment on the aircraft. The weight of the shoring must be included in the weight of CESE. The shoring is placed on CESE at the weighing and marking station which should be close to the location where the shoring is to be used.

Roller shoring (fig. 2-9) is required for tracked equipment. Roller shoring protects airport parking ramps and the cargo floor or loading ramps of cargo aircraft.

Parking shoring (fig. 2-10) is required for grader blades, front-end loader buckets, rollers, and so forth. Any vehicle requiring roller shoring requires parking shoring. The minimum thickness of parking shoring is three-fourths inch. Parking shoring is also required

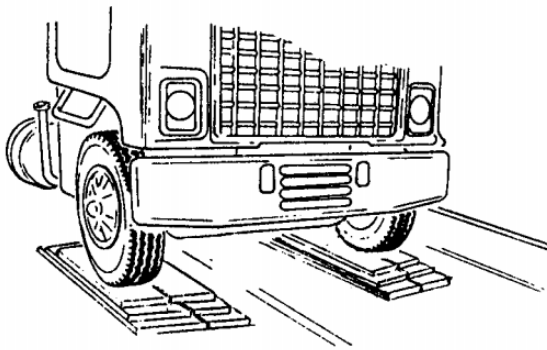

PNEUMATIC TIRES

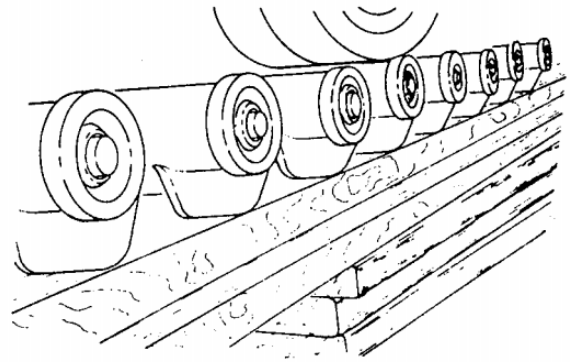

TRACKED

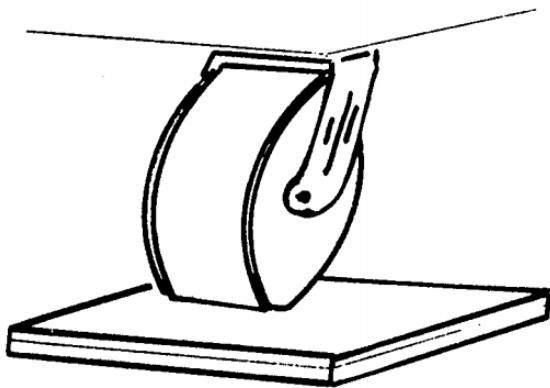

STEEL WHEEL

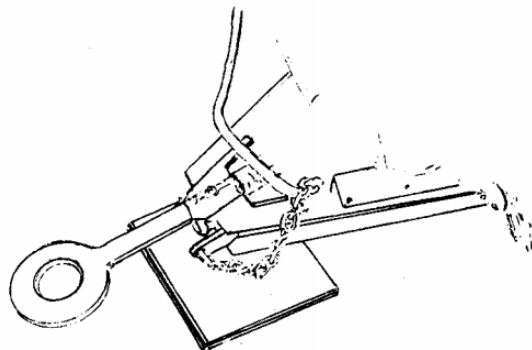

TRAILER TONGUE

Figure 2-10.—Parking shoring.

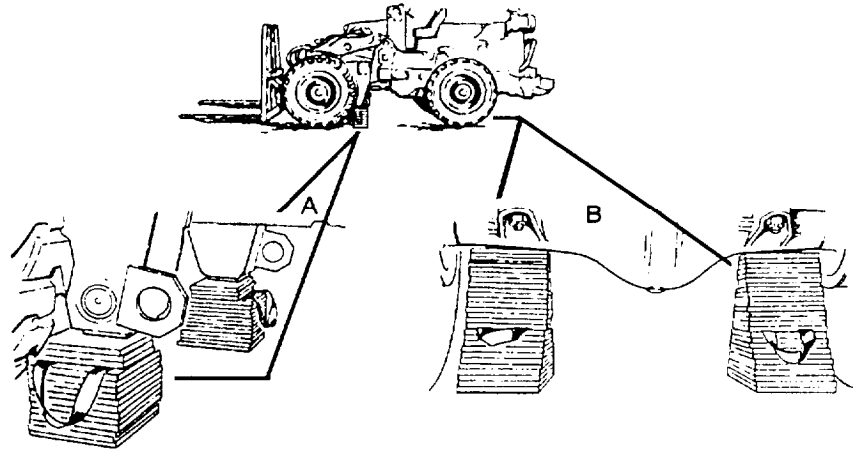

Figure 2-11.-Sleeper shoring.

for all vehicles and cargo that exceed aircraft specific floor weight limitations.

Sleeper shoring (fig. 2-1 1) is used under the frame or axle of a vehicle that exceeds 20,000 pounds and is equipped with soft tires. This shoring is used to prevent the vehicle from bouncing up and down and possibly pulling the tic-down rings out of the aircraft floor.

Approach shoring (fig. 2-12) is used to decrease the approach angle of aircraft loading ramps, because some items of cargo will strike the aircraft or ground during loading or off-loading operations. Long vehicles, such as low-boy trailers, that have limited ground clearance require a varying amount of approach shoring.

The air det must maintain custody of all shoring throughout the mission. Shoring should not be used as tent flooring, tables, or as chairs. Shoring can be easily misplaced and should be stored off the ground in one location to prevent insect infestation, rot, or theft. The equipment platoon should account for all shoring assigned to each piece of CESE because this shoring will be required for additional airlift plans. Shoring requirements for air certified air det CESE is listed in the *Naval Construction Force Embarkation Manual*, COMSECONDCOM-THIRDNCBINST 3120.1 series.

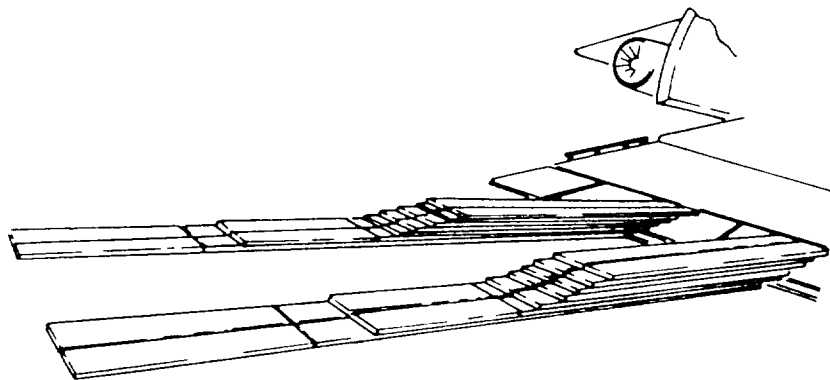

Figure 2-12.—Approach shoring.

PALLETIZED CARGO

Pallets and pallet nets are procured from the Air Force. The 463L pallet (fig. 2-1) is standard system for the movement of concentrated cargo used by the Air Force. Military airlift aircraft are equipped with a dual-rail system consisting of rows of rollers which allow 463L pallets to move easily into and out of the aircraft. The 463L pallet is made of corrosion-resistant aluminum and has a soft wood core. The pallet has an outside dimension of 108 inches by 88 inches and is 2 1/4 inches thick. The cargo area space is 104 inches by 84 inches which is enough space to

allow 2 inches around the 436L pallets to attach straps, nets, or other restraint devices. A 436L pallet weighs 290 pounds empty and has a maximum load capacity of 10,000 pounds; however, to prolong pallet life, a load placed on a pallet should not exceed 7,500 pounds.

Pallet nets provide adequate restraint for 10,000 pounds of cargo when properly attached to the 463L pallet. There are three nets to a set: two side nets and one top net (fig. 2-13). The side nets are green in color, and the top net is yellow. The side nets attach to the rings of the pallet, and the top nets are attached by hooks to the side nets. These nets have multiple

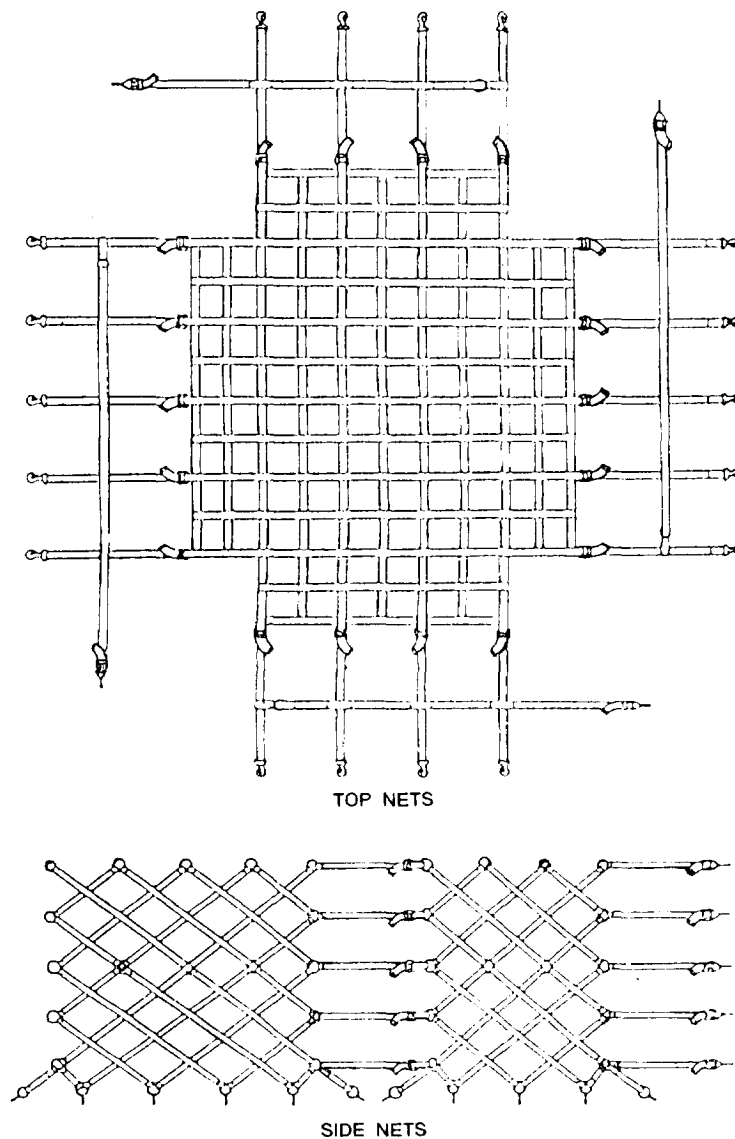

Figure 2-13.—463L pallet nets.

adjustment points and may be tightened to fit snugly on most any load. A complete set of 463L nets (three nets) weighs 65 pounds. Other cargo restraints are chains and chain tie-down devices. These are used for large items, such as Conex boxes, Seabee shelters, and refer units, and so forth. Five-thousand-pound tie-down straps (fig. 2-14) are used to secure equipment attachments and provide individual item restraints. Additionally, the tie-down straps provide supplemental restraint to the 463L pallet nets.

Cargo is palletized from the heaviest to the lightest. Large and heavy objects are distributed evenly from the center of the pallet outward to prevent the pallet from becoming heavy on one end (fig. 2-15). Additionally, this helps maintain the center of balance at or near the center. Lighter or smaller items are positioned on top or along the side of the heavier cargo. Containers marked "THIS SIDE UP" are placed upright, and cargo with special labels are faced outward whenever possible. Pallets should be constructed in a square or pyramid shape whenever possible (fig. 2-16). This makes the load stable, easy to handle, and easier to secure on the pallet. Each 463L pallet requires dunnage under the pallet when not on board the aircraft. The dunnage consists of three pieces of 4-inch by 4-inch by 90-inch timber and is placed in the center and close to the outside edges of the pallet. This prevents the pallets from warping and enhances forklift operations. Each aircraft has restrictions as to the dimensional size and shape particular to that specific aircraft. Aisleways must be built on pallet position three or four in a C-130 aircraft. Check the particular requirements of the aircraft for which the load is prepared.

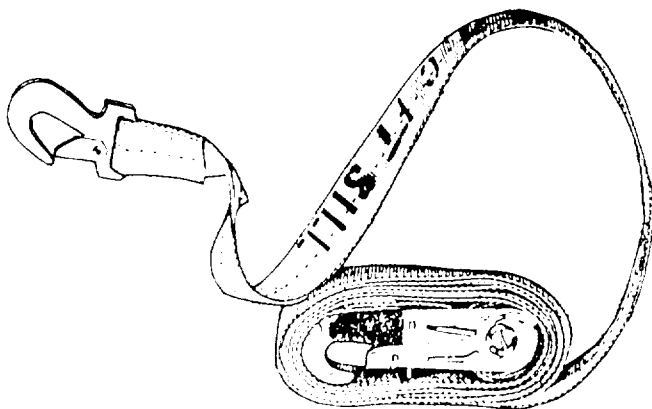

Figure 2-14.—5,000-pound tie-down strap.

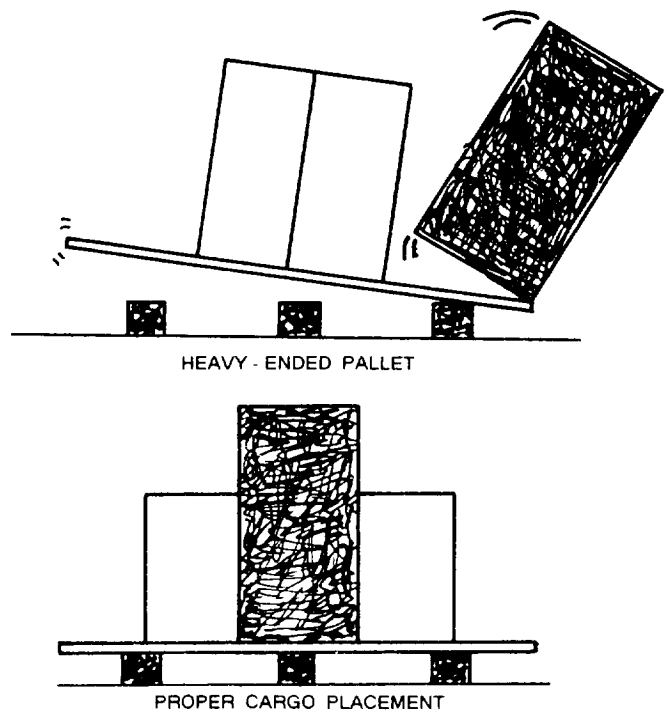
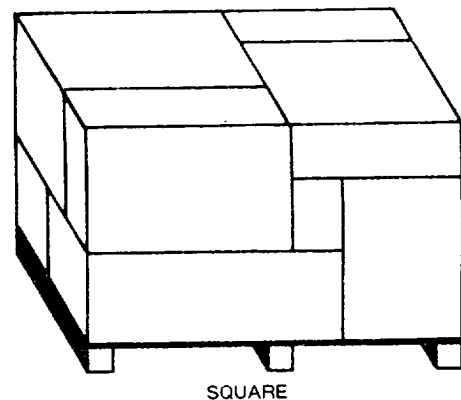
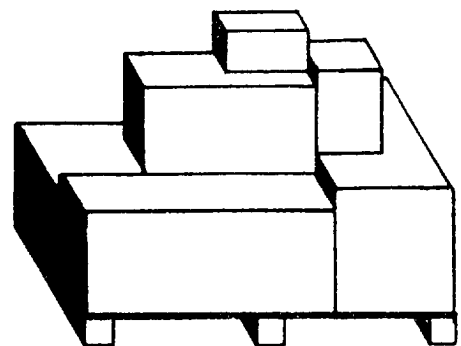

Figure 2-15.— Pallet cargo placement.



SQUARE



PYRAMID

Figure 2-16.—463L square and pyramid pallet cargo placement.

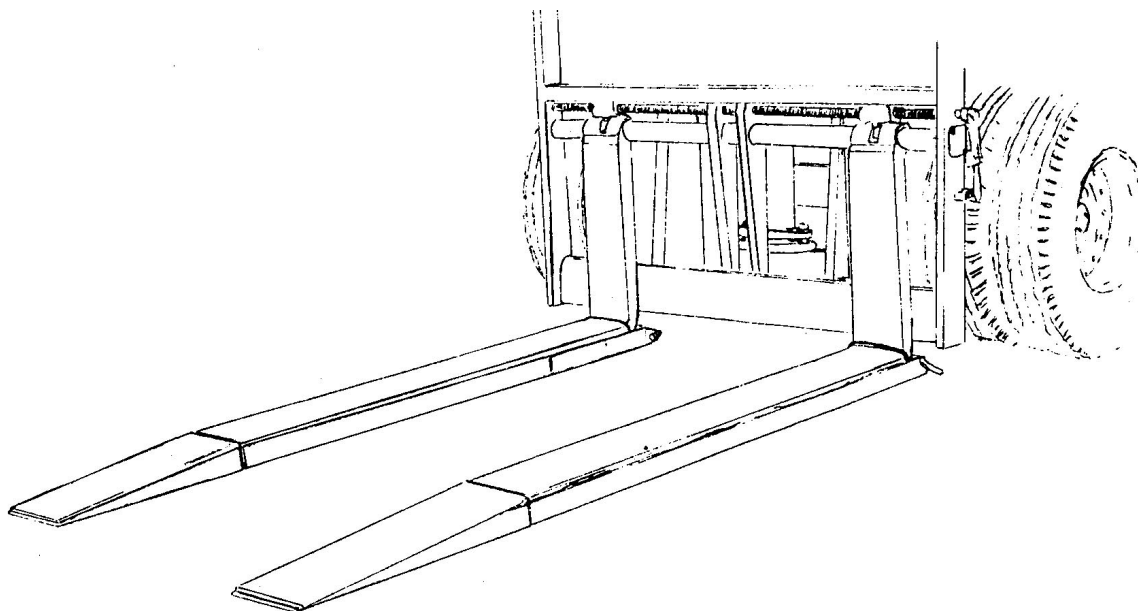

Figure 2-17.—Bare tine extenders.

The marking of the center of balance is not necessary on individual 463L pallets. When 463L pallet loads are built correctly, the center of balance will be at or near the center. The pallets are weighed by using portable scales. The weight of the dunnage must be weighed with the pallet. The scaled weight of the pallet is recorded on the manifest and labeled on each side (88-inch dimension) of the 463L pallet.

Handling and loading 463L pallets with a forklift requires the use of fork extensions (tine fork extenders) in order to support the weight and size of the pallet fully. Technical publications that govern loading procedures for aircraft require forklift tines be a minimum of 72 inches in length.

Tine extenders are designed in two configurations: bare tine extenders (fig. 2-17) and rollerized tine extenders (fig. 2-18). The rollerized version of tine extenders is best suited for the rapid handling of 463L pallets, while the bare tine extenders are more useful in pallet building and the placement of mobile loads on beds of vehicles. Either type of extender is acceptable and can be locally manufactured; however, extreme care must be exercised when handling 463L pallets, because the tine tips can easily damage a pallet surface and render it unusable. To allow for unloading aircraft and handling pallets at the campsite, you must ensure a set of tine fork extensions are embarked with the cargo

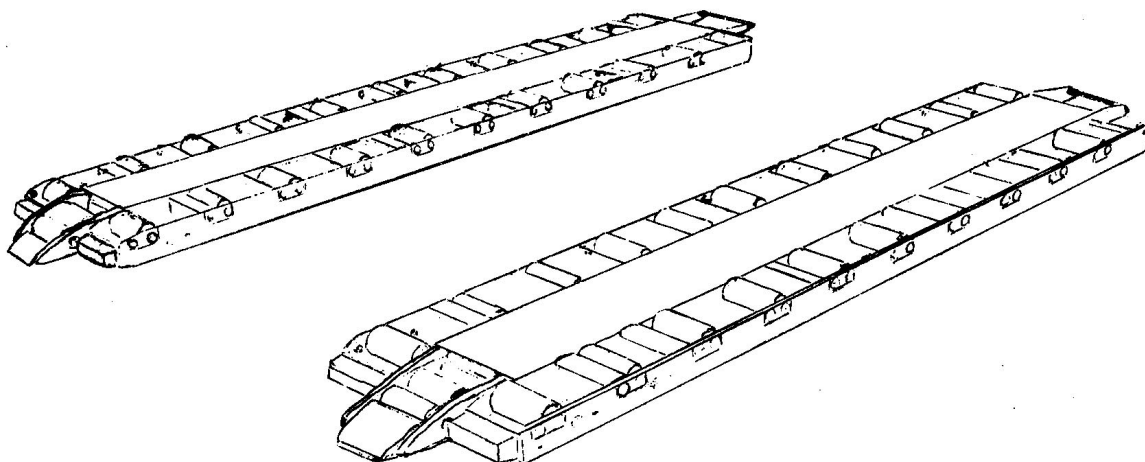

Figure 2-18.—Rollerized tine extenders.

and CESE. The 12K Lift King forklift currently assigned to the NCF TOA has a set of roller tine fork extensions assigned as an attachment.

Once the air det has arrived on site, the pallet loads are usually broken down and a supply area is set up for material and tool distribution. Never leave the pallets, pallet nets, chains, chain tie-down devices, and even the 5,000-pound cargo straps laying around. When you do, there is a good chance they will be rendered useless after being run over, walked on, buried, or otherwise damaged or destroyed. The recommended procedure for storing pallets is to place down three sets of 4-inch by 4-inch dunnage and stack the pallets ten high. Then, place three more sets of 4-inch by 4-inch dunnage and stack ten more pallets. Never stack pallets upside down. This could damage the rings or the aluminum surface. Also, never stack pallets over 40 high. Store all the 4-inch by 4-inch dunnage, chains, chain tie-down devices, and cargo straps in one location, and protect pallet nets from adverse climatic conditions. The netting materials may mildew and deteriorate, and the metal hooks can rust if not properly cared for. The air det must maintain custody of 463L pallets, pallet nets, 4-inch by 4-inch dunnage, chains, chain tie-down devices and cargo straps throughout the mission. These items are extremely expensive to purchase and refurbish and could be required for future airlift plans.

COLLATERAL EQUIPAGE

The Alfa company collateral equipage custodian delegates the responsibility and accountability of the air det CESE collateral equipage and attachments to the equipment platoon supervisor. This area of responsibility is usually delegated to the assigned air det collateral equipage custodian. The custodian needs to acquire a list of the collateral equipage and attachments embarked with the air det CESE. The responsibilities of the air det collateral equipage and attachment operation are the same as the battalion and is outlined in *Equipment Management*, COM-SECOND/COMTHIRDNBINST 11200.1 series and covered in chapter 1 of this TRAMAN. Proper management of collateral equipage and attachments enhances YOUR equipment management program for the air det. When this area is neglected, a high cost air det collateral equipage and attachment turn-in can occur and detract from any effective equipment management program you may have attempted to enforce.

SITE SELECTION

The equipment platoon supervisor works closely with the air det staff when considering an area to set up the equipment platoon operations. The selection of the site depends upon the mission, the terrain, and climatic conditions. When possible, locate the equipment platoon operations close to the center of activity to allow the equipment to be used economically and efficiently.

Drainage must not be overlooked. In some areas you may already have natural drainage, while other areas may require construction of extensive drainage systems. You must remember that large-scale grubbing operations often produce damaging environmental effects. Save as much vegetation as possible to prevent soil erosion.

Allow adequate space to turn around tractor-trailers, to build an equipment loading ramp, to build an equipment parking area, and an area for equipment maintenance operations. Consider areas to disperse the equipment in a tactical environment to lessen possible damage from rocket or mortar attacks. Equipment parked in a neat, close file or in rows present large targets. Additionally, make sure entrances and exits are laid out to allow for a smooth flow of traffic and wide enough to accommodate the largest piece of construction equipment.

Other areas to consider are as follows: locations for collateral equipage and attachments, dispatch and maintenance tents, POL storage, storage for vehicle shoring, storage for the 463L pallets, and the vehicle wash area.

SITE ARRIVAL

When the air det embarks by airlift, all members of the air det are listed on the manifest and are scheduled to fly by chalk numbers. The number of passengers (PAXs) allotted on an aircraft depends on the weight of the cargo or CESE loaded on the aircraft. The Equipment Operators (EOs) assigned to a specific CESE accompany that CESE aboard the aircraft.

Normally, EOS are assigned, with support from other ratings, the duties of the Arrival Airlift Control Group (AACG). The AACG group is usually scheduled to fly out on the first chalk, and at the mission site supports the Air Force with the unloading and staging of cargo and CESE from the aircraft. The

AACG group normally remains at the air base until all the scheduled chinks arrive at the mission site.

The equipment platoon transports cargo, baggage, CESE, and personnel from the air field to the deployment site. This movement may require a tactical convoy or a nontactical convoy procedure. Convoy procedures are outlined in the *Naval Construction Force Embarkation Manual*, COM-SECOND/COMTHIRDNCBINST 3120.1 series, and *Equipment Management*, COMSECOND/COM-THIRDNCBINST 11200.1 series.

During the first few days of an air det mission, before the supplies and CESE arrive and the camp is completed, the troops endure abnormal living conditions which can be detrimental to their morale. Once the supplies start to arrive, the set up of priority areas should immediately begin. These areas are the shower tent for hot showers, the galley tent for hot meals, and berthing tents to store gear and to sleep in. When provided properly, these facilities will make a PROFOUND difference in the morale and welfare of the troops.

The support platoon has the key responsibility for the camp setup. Some of the platoon's responsibilities are: camp electrical distribution, camp tent layout, galley facilities, shower facilities, laundry facilities (depending on the duration of the mission), medical facility, communications gear setup, latrines, and so forth. The construction of an air det camp is an "all hands" effort.

Delays can hamper plans for personnel, supplies, CESE, and construction operations and force the air det to have to regroup and manage with the resources on hand. Therefore, every operation the air det is involved in must be prioritized.

EQUIPMENT PLATOON OPERATIONS

The equipment platoon primary responsibility is to support the requirements of the support platoon; however, it also has its own areas of responsibility. One area of responsibility is the control and accountability of CESE. When control and accountability of CESE is delayed and not implemented at the start of the mission, problems are sure to develop. Some problems you can expect are unexplainable damages to CESE, lost keys, neglected operator maintenance, loss of collateral equipment, and even theft.

Dispatch operations must start at the very beginning of the mission. All operators who are assigned to fly with a piece of CESE must report to the dispatcher when the CESE arrives at the mission site. The dispatcher should have an equipment status board that denotes the status of all CESE and have an area to secure equipment keys. Dispatch operations may have to be performed out of a box before the dispatch tent is erected. The dispatcher must plan for these situations. The best method for control and accountability is to Class "C" assign all CESE.

The air det has to account for all hours and mileage put on CESE during a mission. The equipment platoon supervisor is responsible for reviewing dispatch logs and trip tickets as outlined in *Equipment Management*, COMSECOND/COM-THIRDNCBINST 11200.1 series, for an Alfa company operations supervisor.

The equipment platoon supervisor must stay on top of all equipment-related operations of the air det. During the first few days of a mission, the forklift is one of the most important pieces of CESE. The forklift is required to reassemble CESE, break down pallets, move tent boxes, unload tractor-trailers, and so forth; therefore, to ensure the optimum use of the forklift, these tasks must be prioritized.

You must remember that SAFETY IS PARAMOUNT and CESE must be reassembled before use. Reassembling CESE is a time-consuming forklift operation that delays individual priorities of other members of the air det. Therefore, it must be understood and enforced that tasks do not always have to be accomplished with the support of equipment and that waiting for the availability of the equipment is not worth the time wasted. Use troops to accomplish tasks that can be done manually (manual labor). Examples are: breaking down pallets, digging latrines, moving tent boxes, unloading trucks, and so forth. These tasks must be accomplished with or without the support of equipment.

The equipment platoon also has the responsibility to check and fill the water buffalos with potable water, maintain the water in the shower water bladders, and make daily garbage runs. These areas must not be overlooked during the planning phase. A piece of CESE (water truck, dump truck) will have to be dedicated to support this task. Water buffalos normally embark empty unless it is determined that potable water is not immediately available.

Equipment repair operations and the use of POL products and 55-gallon fuel drums must be closely monitored to avoid any contaminating spills. Lubricating oil, fuel, hydraulic fluids, transmission fluids, and antifreeze contain hazardous chemical properties. When these items are mishandled and spilled, they can leak into the groundwater system or into the human food chain. Mishandling the “hurdy-gurdy” while dispensing fuel in vehicles or in fuel cans can cause excessive fuel spills that can be disastrous to the environment. Fifty-five-gallon fuel drums and POL products should be stored at least 50 feet away from any structure and located so vehicles and equipment can be easily topped off at the end of each day. Depending on your mission, the POL products and 55-gallon drums should be in a protected position (away from likely avenues of attack) that provides protection to the fuel storage area as well as to adjacent facilities. Fire extinguishers must be placed for easy accessibility and “No Smoking” signs must be posted in the POL products and fuel storage area.

Embarked with limited resources, the maintenance field crew and field crew truck play a major role throughout the air det mission. The field crew truck is loaded with the necessary tools and consumable supplies. These tools and supplies support the reassembling of CESE, setting up light plants, setting up camp electrical supply (generators), repair of hand tools, and so forth. Additionally, the maintenance field crew is required at the airfield during aircraft flight unloading operations in case a piece of CESE can not start or breaks down while on board the aircraft. Depending on the mission, the maintenance field crew truck can be used for delivering fuel by loading and securing a 55-gallon drum of fuel in the back of the truck. This expedites fuel runs for equipment on construction projects or for the camp generators. The requirements for maintenance field crew support requires a radio for communications with the maintenance field crew and the air det camp. A field crew must be equipped with the proper communication capability to respond to mission requirements expeditiously.

The air det maintenance supervisor should direct the operations of the maintenance field crew and also know the status of all CESE assigned to the air det. The maintenance supervisor has the responsibility to set up the maintenance shop and set up a preventive maintenance schedule for CESE assigned. All maintenance performed that requires repair parts, lube oils, or exceeds one man-hour must be documented.

Depending on the duration of the mission, the air det normally schedules means for logistic support and communications with the main body. Equipment repair parts not covered in the mod 96 or mod 98 normally can be acquired through this logistic support. The air det maintenance and equipment management program should mirror that of the main body. The management guidelines are provided in *Equipment Management*, COMSECOND/COM-THIRDNCBINST 11200.1 series.

The success of the air det mission is primary, but should not be attained at the cost of destroyed CESE. Operator’s maintenance is mandatory and must be strongly enforced by the entire air det chain of command. CESE damaged by operator negligence or lack of operator maintenance is unacceptable. Equipment failure can seriously jeopardize mission success.

PROJECTS

The primary purpose of the construction platoon is to perform construction operations for the air det with the support of the equipment and support platoons. Construction tasking covers a large range of tasks that include disaster recovery operations, war damage repairs, rapid runway repairs, humanitarian relief, and constructing advance base functional components. The tailoring of ratings assigned to the air det is dependent upon the extent and variety of the assigned tasking.

The amount of time allotted to plan construction projects depends on the urgency of the air det to embark to the mission site. Urgent situations can cause the air det to embark and manage construction projects with just the basic TA41 items. The equipment platoon supervisor has to plan CESE support for the construction projects, and priorities should be set up as soon as possible due to the limited amount of CESE embarked with the air det. Remember, priorities are subject to change, depending on operational conditions.

AIR DET MOUNT-OUT/RETROGRADE

At the completion of the mission, the air det receives orders from higher command to prepare to mount-out to relocate or to return to the main body site. The air det will have to mount-out itself to include the weighing and balancing of CESE, building pallets, developing load plans, and developing convoy procedures, if required. The air

det should divide into two shifts (fig. 2-19) to achieve maximum production and to avoid overworking the troops.

The equipment platoon supervisor plays a key role, along with the air det staff, when prioritizing CESE and supplies to be mounted out. Certain CESE and supplies, such as tractor and trailers, forklifts, the maintenance field crew truck, light plants, and various tools, are required. These CESE and supplies are used to support the building of pallets, disassembly of CESE, breakdown of the camp, garbage runs, hauling of CESE, and transport supplies and personnel to the staging area. This movement from the campsite to the airfield may require a tactical or nontactical convoy procedure.

Another area the equipment supervisor must consider is a productive method for washing and

preparing CESE for the mount-out. The task of cleaning CESE is one that must not be overlooked and should be addressed before deploying to the mission site. The prepping of CESE in the field can be a time-consuming task and, if not properly planned, could result in not meeting the deadline for the joint inspection.

An efficient means for washing CESE is to locate a washrack or to build one. Some considerations in selecting the location of the washrack are as follows: the distance the CESE must be driven once it has been washed, the amount of water required to wash each piece of CESE (if using the water truck), and the distance the water truck must travel to obtain water.

A pressure washer located at the washrack is desirable and should be augmented to the air det; however, they are sometimes hard to obtain. Some

SAMPLE AIR DETAIL MOUNT-OUT ORGANIZATION		
EMBARK OFFICER - _____		
LOAD PLANNERS - _____, _____, _____		
DASH TWO CERTIFICATION - _____, _____		
	<u>STAGING AND CESE PREPARATION</u>	
<u>PALLET BUILDING</u>	DAY	NIGHT
CREW LEADER	_____	_____
FORKLIFT OPERATOR	_____	_____
CREW ONE	_____	_____
	_____	_____
CREW TWO	_____	_____
	_____	_____
CESE INSPECTOR	_____	_____
<u>WEIGHING AND MARKING</u>		
CREW LEADER	_____	_____
	_____	_____
<u>CESE PREPARATION</u>		
CREW LEADER	_____	_____
	_____	_____
	_____	_____
MECHANICS	_____	_____
	_____	_____
	_____	_____
	ARRIVAL / DEPARTURE AIRLIFT CONTROL GROUP (AACG / DACG)	
	AACG	DACG
LPO	_____	_____
FORKLIFT OPERATOR	_____	_____
CREW	_____	_____
	_____	_____
ALTERNATES	_____	_____
	_____	_____

Figure 2-19.—Sample of the air det mount-out organization.

pressure washers require small quantities of water and can be connected to a water buffalo with a garden hose to provide a very efficient tool for washing CESE.

A de-bugging steam wash may be required on all CESE that is to be returned to the host country. Normally, this is a rule directed by the Department of Agriculture of the host nation.

After all the pallets are built and the CESE is prepared, the air det has the responsibility to develop its own load plans and to set up the marshaling area by chalks. A pre-JI inspection is normally held that allows the air det time to correct any discrepancy. Again, operators must stand by their CESE during the inspection.

The "fly away" can take several days; therefore, arrangements should be made for rations and berthing for those personnel who are scheduled on the last chalks. The maintenance field crew is normally among those personnel. The field crew is required to stand by to repair any unplanned breakdowns of CESE that are to be loaded on the aircraft. Another group of personnel that remains at the airfield is the Departure Airlift Control Group (DACG). The DACG supports the Air Force with the loading and securing of CESE and 463L pallets onto the aircraft.

Normally, the majority of air det personnel are manifested to be on the first group of chalks to fly out. These members will have the responsibility to perform the air det retrograde. The retrograde is the period of time used to inventory, reorder, clean, and

turn in all the supplies and gear embarked with the air det.

Normally, CESE returning from the air det operation is directed through the maintenance shop. This allows CESE to receive an acceptance check before being returned to the field. The air det maintenance supervisor turns in all the EROs, 1250s, and vehicle history jackets (if deployed more than 30 days) used during the mission to the cost control clerk. The license examiner turns in all license related items and any accident reports to the battalion license examiner and the air det dispatcher turns in the closed out dispatch logs, hard cards, and mileage reports to the battalion dispatcher. All collateral equipment is inventoried and turned over to the battalion collateral equipment custodian.

After the completion of the retrograde, the air det chain of command will forward an after action report to the battalion chain of command. This report contains a daily diary of events, the personnel embarked, CESE and supplies embarked, task assigned and completed, man-days expended, and lessons learned, and so forth. Therefore, remember to keep records of lessons learned throughout the mission. This will support the after action report, plus help plan future missions

Remember, the final condition of CESE, the positive accountability of collateral equipment, and the positive accountability of tool kits are your final grade on how well the equipment management program was conducted during the air det mission.

CHAPTER 3

CRANE CREW SUPERVISOR

In minutes, a crane can easily lift and place a load weighing several tons. Major tasks involved in any construction or ship-loading operation are the handling of supplies, the driving of piles, and the excavation of materials. Most of these tasks are performed by equipment belonging to the lifting and loading family. Part of this family are cranes with various attachments, such as hook block, clamshell, dragline, and pile driver. Cranes provide safe and efficient accomplishment of assigned tasks when operators use them properly and demonstrate the same respect for the crane as they should any other labor-saving device; however, the first time you bend the rules or take shortcuts, disaster is waiting to happen.

As a direct result of OPERATOR ERROR, crane accidents take heavy and tragic tolls each year. People are crippled or killed and enormous property damage is incurred as a direct result of crane accidents. Nine out of ten crane accidents that occurred in the past could have been avoided. Over eighty percent of these accidents were due to operator inattention, poor judgment, overconfidence, or excessive speed.

The Naval Construction Force (NCF) has for many years recognized the requirement for an extensive crane safety program. The crane safety program applies to crane operators and the safe operation of weight-handling equipment. Standards for weight-handling equipment operations are outlined in the *Management of Weight-Handling Equipment*, NAVFAC P-307; *NCF Equipment Management Manual*, NAVFAC P-404; *NMCB Equipment Management*, COMSECOND/COM-THIRDNCBINST 11200.1 series; *Use of Wire Rope Slings and Rigging Hardware in the NCF*, COMSECOND/COMTHIRDNCBINST 11200.11; and *Testing and Licensing of Construction Equipment Operators*, NAVFAC P-306.

CRANE CREW SUPERVISOR RESPONSIBILITIES

The Naval Construction Force crane crew supervisor is assigned and designated in writing by

the commanding officer. The person selected is normally the best crane operator available within battalion-wide assets. The equipment officer, crane test director, and the crane crew supervisor share the responsibility of ensuring that any crew that prepares, assembles, operates, or works with or around cranes are well trained in both safety and operating procedures.

CRANE CREW

The equipment officer and the Alfa company operations chief should select the crane crew at the beginning of the home-port period. Construction tasking requiring crane support and the number of cranes assigned in the TAB A dictate the size of the crane crew.

During the home-port period the crane crew supervisor should be aware of and review all construction tasking that requires crane support. A knowledge of crane operations enhances your ability to make proper plans to meet construction tasking. Proper planning means you select the correct number and types of crane lifts, assign the correct type of crane needed to accomplish the task, select the correct rigging gear, and assign a competent crew to perform the lift. Additionally, if any special skills are required to perform any of the tasking, you should know that special training can be coordinated through your battalion training department with the Naval Construction Training Center (NCTC), Port Hueneme, California, or Gulfport, Mississippi.

Qualifications

The skills and safety standards demanded for efficient crane operations require only mature professionals be assigned as crane operators and riggers on a crane crew. Equipment Operators must meet the minimum physical examination requirements as established by the NAVFAC P-306. Additionally, they must pass a written and operational skills test.

Crane License Program

Before receiving a license to operate a crane, crane operators are required to attend 40 hours of formal classroom instruction on crane operating safety, as outlined in the NAVFAC P-306. The Naval Construction Training Centers (NCTC), Port Hueneme, California, and Gulfport, Mississippi, offer a crane school that covers the requirements of the NAVFAC P-306. Additionally, operators who need to renew their license and have completed the 40 hours of crane safety must attend a minimum 8-hour refresher training course on crane operator safety.

The testing of crane operators is the direct responsibility of the crane certifying officer and cannot be delegated. The crane certifying officer may be assisted in administering a performance test by the crane test director. Performance tests are conducted, as outlined in the NAVFAC P-306. The crane manufacturer's manual is used to test the operator on the operator's maintenance responsibility.

The equipment officer is normally responsible for the duties of the battalion crane certifying officer. As outlined in the NAVFAC P-307, the crane certifying officer must be designated in writing by the commanding officer of the activity. The crane certifying officer designates in writing the crane test director.

A crane license is issued on the Construction Equipment Operator License, NAVFAC 11260/2, and will indicate the make, model, capacity, and the attachments the operator is qualified to operate. Operators requiring more on-the-job training with cranes can be issued a training license for a period of 30 days. The trainee must be under the supervision of a qualified crane operator. The training license must denote the make, model, capacity, and the attachment on which the operator is to be trained.

Before you deploy, ensure that the crane crew has several licensed crane operators. Your licensed operators will be needed to support the Battalion Equipment Evaluation Program (BEEP) of the cranes. The crane certifying officer designates in writing the crane test operator and the crane test mechanic. These positions are required for the crane certification program. The crane certifying officers may also designate an alternate crane test director, test operator, and test maintenance backups.

BEEP

Cranes are normally condition inspected, load tested, and certified annually, as prescribed in the NAVFAC P-307; however, in the NCF, test procedures for cranes are performed during the BEEP as a joint battalion effort. Time management is important when performing the BEEP of the crane area of responsibility. You must remember that the weight testing of cranes is a time-consuming event and should be completed before the end of the BEEP.

The BEEP Equipment and Attachment Evaluation Inspection Guides for cranes are issued by the dispatchers. The inspections of the cranes are performed jointly by the EOs assigned to the crane crews. Once the EOs have completed the Equipment and Attachment Evaluation Inspection and the paper work is taken to the dispatcher, the crane mechanics will jointly inspect the crane, using the inspection guides. The crane mechanics also have the responsibility of performing the Crane Condition Inspection which is documented on the Crane Condition Inspection Record (figs. 3-1A and 3-1B). This inspection, commonly known as the "before, during, and after inspection," is part of the crane weight-testing procedure and can be performed at the same time the mechanics are performing the equipment and attachment inspection. The crane test director is also responsible for inspecting and reviewing the items on the Crane Condition Inspection Record.

After the crane is released from the shop, the crane crew supervisors have the responsibility to prepare the crane for the weight-testing procedure. Accomplishing the weight test for certification of the crane is important, because the ERO for the crane cannot be closed out until the crane is certified.

The weight testing of cranes requires the use of big, heavy weights, a stable foundation, and an area clear of obstructions. Some deployment sites have an area in Alfa company with weights for the weight testing of cranes; however, Public Works Centers overseas normally has an area allocated for the weight testing of cranes. They normally allow the battalions to schedule time periods for use of this area.

When a crane has to be transported to the weight-testing-area, the crane crew supervisors must receive the planned travel route to determine if low wires, low overpasses, narrow bridges, or unsafe obstacles exist. The absolute limit of approach for

CRANE CONDITION INSPECTION RECORD

Crane No. 82-00001	Type Truck Crane	Location Pier 4	Operator names John A. Doe		Operator License Nos. 3-1000H	
Purpose of inspection: TYPE C INSPECTION			Date started 5-24-92		Date completed 5-26-92	
Item No.	Item description	B	D	A	Insp/ Init.	
1	Bent, cracked, or corroded structural members	S	S	S	LS	
2	Cracked or corroded welds	S	S	S	LS	
3	Loose, broken, missing, or deteriorated rivets or bolts	S	S	S	LS	
4	Inspect all wire rope for wear, broken wires, corrosion, kinks, damaged strands, crushed or flattened sections, condition of sockets, and dead end connections. Check for proper lubrication and evidence of proper inspection of idler sheaves and saddles. See Appendices C and D for detailed inspection requirements and rejection criteria.	S	S	S	LS	
5	Inspect hooks for cracks, sharp edges, and distortion. Verify disassembly, inspection, and nondestructive test (NDT) as applicable. See paragraph 1.4 of Appendix E for detailed requirements.	S	S	S	LS	
6	Inspect all brakes and clutches for proper operation. Spot check components for proper adjustment and acceptable wear.	S	S	S	LS	
7	Check all controls for proper condition and operation	S	S	S	LS	
8	Check all control components for proper condition and operation	S	S	S	LS	
9	Inspect all limit switches for condition and proper operation	S	S	S	LS	
10	Ensure each drum has minimum of two complete wraps of wire rope at lowest working level	S	S	S	LS	
11	Check load indicators for condition and working accuracy	S	S	S	LS	
12	Inspect all mechanical equipment which is reasonably accessible for wear, cracks, and alignment	S	S	S	LS	
13	Inspect where practical for worn, defective, or misaligned bearings, bushings, shafts, pins, and gears.	S	S	S	LS	
14	Check components for excessive heat, vibration, noise, and oil leaks	S	S	S	LS	
15	Inspect sheaves for wear, roughness, free-turning, and alignment. Gauge sheave groove where possible.	S	S	S	LS	
16	Inspect for excessive wear of wheels, tires, rollers and roller paths or rails	S	S	S	LS	

Figure 3-1A.—Crane Condition Inspection Record (Front).

Item No.	Item Description	B	D	A	Insp/ Init.
17	Inspect for excessive wear of chains and sprockets. Measure chain stretch of load chains.	S	S	S	LS
18	Verify that correct certified capacity charts or hook load rating data is in view of operator and/or rigging personnel	S	S	S	LS
19	Inspect operators cab for cleanliness and operation of all equipment	S	S	S	LS
20	Check machinery house for cleanliness, proper safety guards, warning signs, and storage of tools and equipment	S	S	S	LS
21	Check operation of all indicators, warning devices, and lights	S	S	S	LS
22	Check for proper type and condition of all fire protection equipment	S	S	S	LS
23	Verify that pressure vessel inspection certificates are posted and current (see NAVFAC MO-324 or appropriate document for test procedures)	S	S	S	LS
24	Check condition and function of outriggers, pads, boxes, wedges, and cylinder mountings. Check level indicators	S	S	S	LS
25	Check center pin nut and steadiment by observing operational behavior during load test (see paragraph 2.2.2, Appendix E)	N A	N A	N A	LS
26	Check travel, steering, braking, and locking devices for condition and proper operation	S	S	S	LS
27	Check radius indicator for accuracy by measuring actual radius in at least two boom positions	S	S	S	LS
28	Check pawls, ratchets, and spuds for proper engagement and operation of interlocks	S	S	S	LS
29	Inspect tanks, lines, valves, drains, filters, and other components of air systems for leakage and proper operation	S	S	S	LS
30	Inspect reservoirs, pumps, motors, valves, lines cylinders, and other components of hydraulic systems for leakage and proper operation	S	S	S	LS
31	Check engines and engine-generator sets for proper performance, safety and system leakage	S	S	S	LS
32	Inspect for bent, cracked, corroded, or dented boom members	S	S	S	LS
33	Check condition of counterweights, ballast, and securing fasteners	S	S	S	LS
34	Check all compartments (voids) for water tightness	NA	NA	NA	LS
35	Check accuracy of list and trim indicators against design data or previous test data	NA	NA	NA	LS
Remarks: NA					
Legend: B--before; D--during; A--after					
Inspector Signature/Date <i>Jack R. Frost CM-1</i> 5-26-92		Test Director Signature/Date <i>Walter T. Don EOC</i> 5-26-92			

Figure 3-1B.—Crane Condition Inspection Record (Back).

power lines must be the following: 0 to 125,000 volts, 10 feet; 125,000 to 250,000 volts, 15 feet; over 250,000 volts, 25 feet. Anytime you are traveling with a crane, stay a minimum of 4 feet from any

electrical power source. You must inspect the crane test pad area, slings and rigging gear, and obtain travel permits if required. This review is documented on the Crane Lift Checklist (fig. 3-2) outlined in the

CRANE LIFT CHECKLIST	
	Date _____
1. Location of lift:	_____
2. Supervisor responsible for lift:	_____
3. Crane operator:	_____
4. Rigger(s)/helper(s):	_____
5. Lift:	_____
a. Description of lift:	
b. Weight of item to be lifted:	_____
c. Was weight estimated: Yes: ___ No: ___ If yes, by whom: _____	
Can weight be verified? Yes: ___ No: ___ If no, contact the crane certifying officer for further instructions.	
6. Crane assigned to lift:	
a. USN #:	_____
b. Capacity:	_____
7. Is travel route free of unsafe obstacles: Yes: ___ No: ___	
If no, explain:	
8. Have travel permits been obtained (if required)?	
Yes: ___ No: ___ N/A: ___	
9. Have operators and riggers been briefed on sequence to be followed during lift?	
Yes: ___ No: ___ If no, explain:	
10. Has crane setup been inspected for stability?	
Yes: ___ No: ___ If no, explain:	
11. Has crane operating area been inspected?	
Yes: ___ No: ___ If no, explain:	
12. Have slings and other hardware being used been inspected?	
Yes: ___ No: ___ If no, explain:	

Figure 3-2.-Crane Lift Checklist.

Crane No.	Type	Location or Assignment	Shift 1 2 3	Date	
Hour Meter Readings Beginning Ending		Hrs Operated This Shift	Operator (Name)	Oiler (Name)	
			Legend: "S" Satisfactory, "U" Unsatisfactory		
Item	S U	Item	S U	Item	S U
Engines-Oil Levels		Walkways, Ladders, Handrails		Radiator Coolant	
Fan Belts		Glass		Tanks (Oil-Air)	
Fuel Oil (Amount)		Hooks		Air Compressor	
Gauges & Indicator Lights		Housekeeping		Battery-Water	
Wire Rope & Reeving		Lubrication		Tires & Wheels	
Limit Switches		Wind Locks & Chocks & Stops			
Brakes		Controllers			
Leaks (Fuel-Oil-Water)		Motors			
Warning Devices		Lights			
Instructions: See reverse side			Fuel Gals	Oil Qts.	Gal
CRANE OPERATOR'S DAILY CHECKLIST					
(FRONT)					

Instructions		
Check all items daily. Suspend operations immediately if an unsatisfactory item effects safety for continued operations and report all such conditions immediately to the supervisor-in-charge.	Report unsatisfactory items not effecting safe operations to the supervisor-in-charge at the end of the work shift.	
Remarks (Unsatisfactory Items)		
Operator Signature	Operations Supervisor Signature	Date
Remarks:		Supplies (Check if required)
Maintenance Supervisor Signature	Date	
(BACK)		

Figure 3-3.—Sample of the Crane Operator's Daily Checklist.

The Crane Lift Checklist must be filled out by the crane crew supervisor or the crane test director before the crane can proceed to any project or make any crane lifts. After the Crane Lift Checklist is completed, make sure you brief the operators and riggers on specifics of the lift and travel conditions.

Crane Operator’s Daily Inspection

Before a crane is operated or transported, it must be thoroughly inspected by the operator. The operator uses the Crane Operator’s Daily Checklist (ODCL) (fig. 3-3). The operator visually inspects and checks each item prescribed on the checklist.

When the operator observes a deficiency of a load-bearing or load-controlling part or safety device (major deficiency) or an operating condition that would cause the slightest loss of control or otherwise

render the crane unsafe, the operator must secure the crane and notify the crane crew supervisor. The crane crew supervisor informs the chain of command of any crane problems.

The NAVFAC Form 11260/4 is additionally used with the ODCL when dispatching the crane. The ODCL is turned into the crane crew supervisor at the end of each day or shift for review and signing. As outlined in the NAVFAC P-307, the minimum requirement for retaining the ODCLs is the ODCLs for the previous month of operation and the ODCLs of the current month of operation.

Wire Rope Inspection

Part of the ODCL inspection is the thorough inspection of all wire rope before using a crane. All running ropes in continuous service must be visually inspected for crushing, kinks, corrosion or other damage, broken wires, and proper lubrication (fig. 3-4). Other areas to inspect are the following:

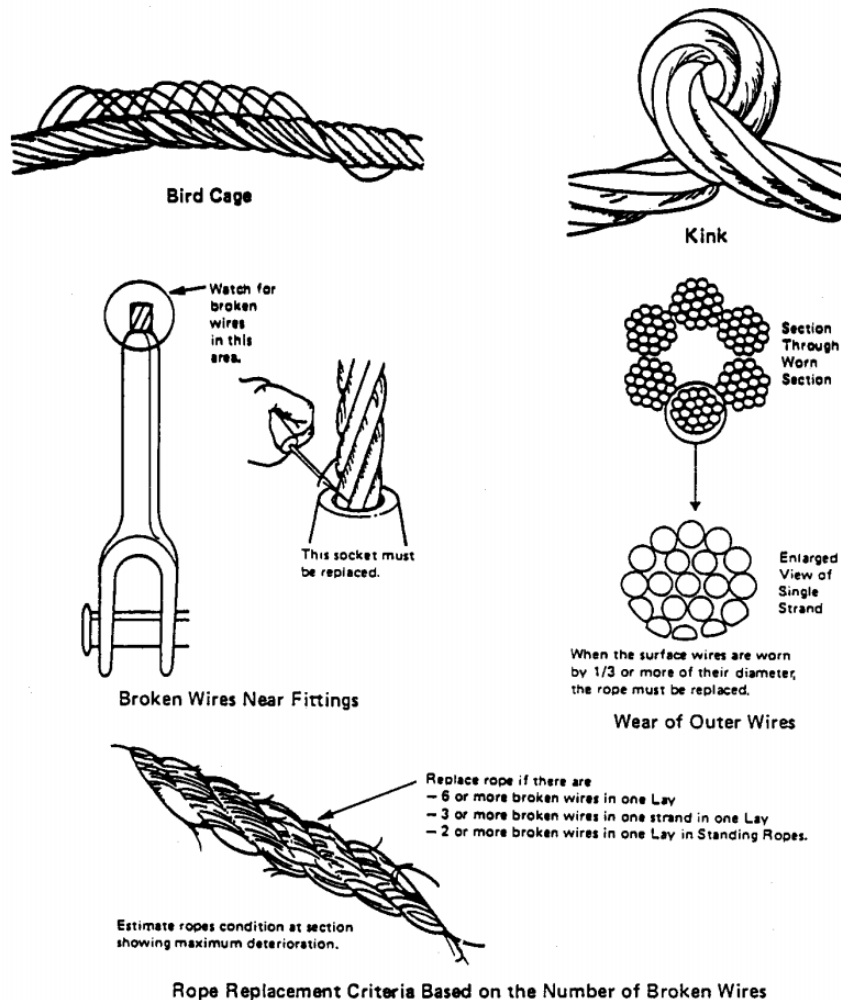

Figure 3-4.—Common wire rope defects.

wire rope sockets, swage fittings, swivels, pendants, and securing hardware for wear. Winch end fittings need only be disconnected or disassembled when experience or visible indications deem it necessary. The exact time for replacement of the rope cannot be given because many variables are involved; however, safety depends upon the use of good judgment in evaluating wire rope. The following conditions are reasons for wire rope replacement:

Running ropes—Six or more broken wires randomly distributed, broken or torn wires in one lay, or three broken wires in one strand in one lay. Replace end connections when there are any broken wires adjacent to the end connection.

Boom pendant ropes—More than two broken wires in one lay in sections beyond the end connection or one or more broken wires at an end connection.

Kinks or crushed sections—Severe kinks or crushed rope in straight runs where the wire rope core is forced through the outer strands.

Flatened sections—Flat sections where the diameter across the flat section is less than five sixths of the original diameter.

Wire rope wear—Measure wire rope with wire rope calipers (fig. 3-5) to check for wear accurately. Replace wire rope that has wear of one third of the original diameter of outside individual wires. A crescent wrench can be used as an expedient means to measure wire rope.

Wire Rope End Connections

Wire rope end connections must be as specified by the manufacturer. If wedge sockets are used, they develop only 70 percent of the breaking strength of the wire rope due to the crushing action of the wedge. Exercise caution when wedged socket connections are used to make rated capacity lifts. Wedge sockets are particularly subject to wear, faulty component fit, and damage from frequent change outs, and are highly vulnerable to inadvertent wedge release, and disassembly in a two-blocking situation. Wire rope clips that clamp both the dead end and live rope must not be used with a wedge socket (fig. 3-6).

MEASURE BETWEEN WIDEST POINTS

TOP OF STRAND TO TOP OF STRAND
ON OPPOSITE SIDE

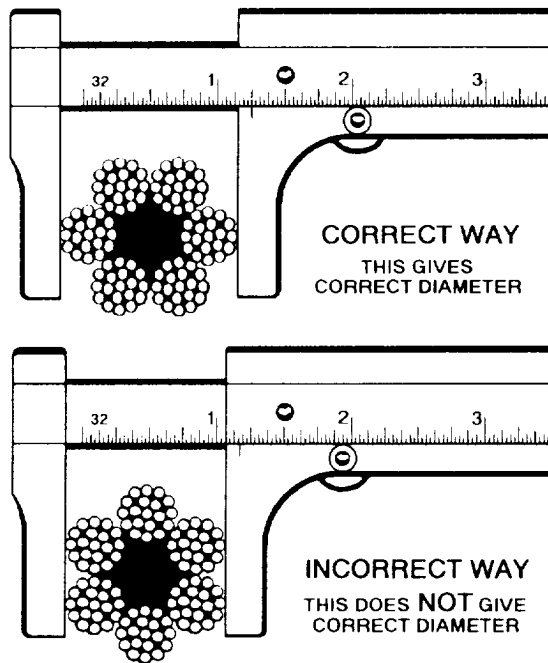

Figure 3-5.—Measuring wire rope.

Such connectors are hazardous because they restrain the wedge from seating properly in the socket. Wedge sockets must be installed as specified in the following procedures:

1. Cut and remove any section of wire rope that was used in a socket and was subject to sharp bending and crushing before resocketing.

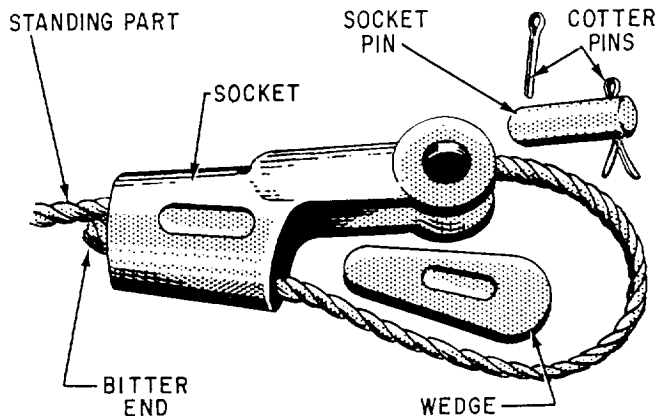

Figure 3-6.—Wedge socket.

2. Install the wedge socket carefully to ensure the wire rope carrying the load is in direct alignment with the eye of the socket clevis pin so the load pull is direct.

3. Place the socket upright and bring the rope around in a large, easy-to-handle hoop. Extend the dead end of the wire rope from the socket for a distance of at least one rope lay length. Insert the wedge in the socket, permitting the rope to adjust around the wedge.

4. As a safety precaution, install a wire rope clamp on the dead end of the wire rope that comes out of the wedge socket (fig. 3-7). Measure the

distance from the base of the wedge socket to the clamp. This measurement is used as a guide to check if the wire rope is slipping in the wedge socket

5. Secure the socket to a support and carefully take a strain on the live side of the rope to ensure the proper initial seating of the wedge. Increase the load gradually until the wedge is fully seated. Avoid applying sudden shock loads.

Hook Block Inspection

The hook block and the hook is part of the ODCL inspection. The operator must inspect the hook block for cleanliness, binding sheaves, damaged or worn

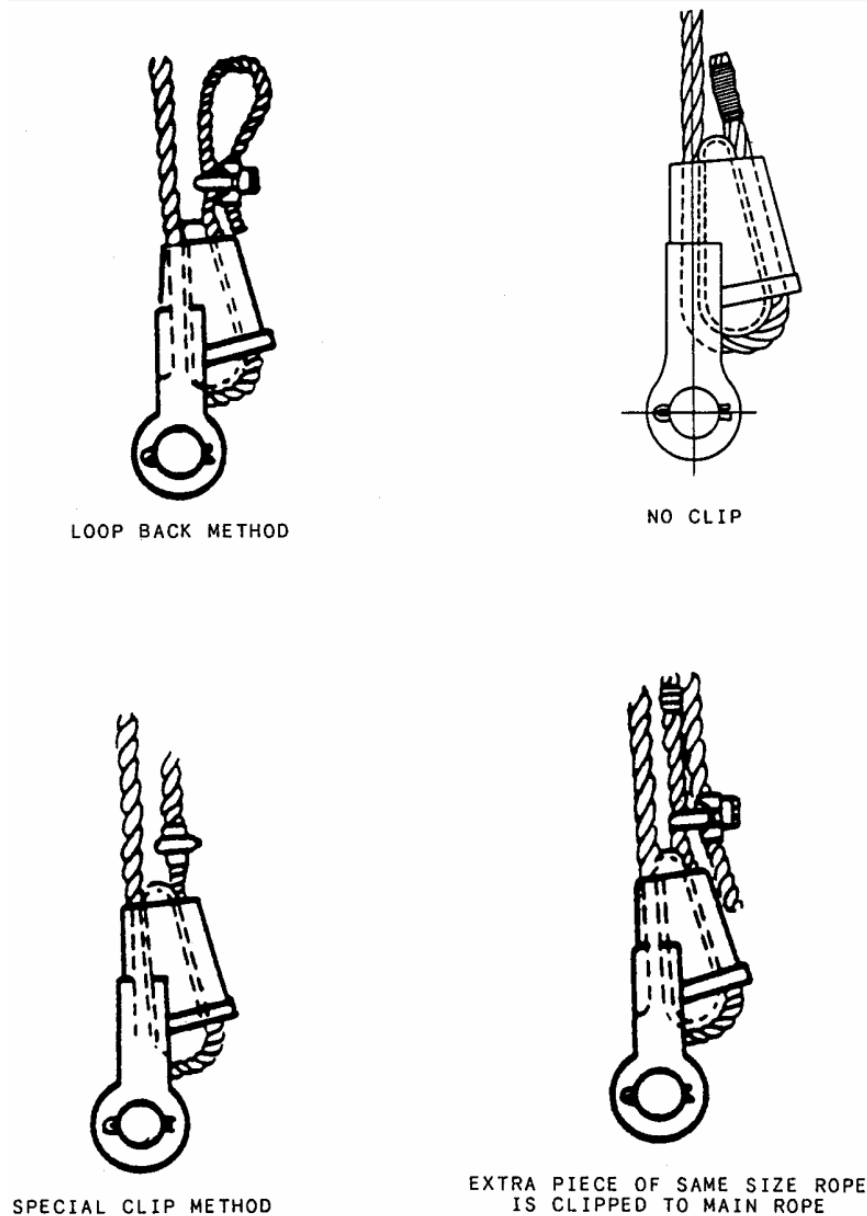

Figure 3-7.—Wedge socket clip method.

sheaves, worn or distorted sheave pins, broken bolts, and worn check weights (fig. 3-8).

The hook is inspected for damage, excessive wear to the hook safety latch, hook swivel trunnions, thrust collar, and securing nut. Also, the hook is inspected for damage or missing lubrication fittings, proper lubrication, cracks and gouges, and if visibly bent or twisted.

Before weight testing the crane, check the hook block certification. Every fifth certification, the hook block should be magna-fluxed and noted on the certification document. The magna-fluxed procedure is normally performed by the Public Works Center.

Part of the weight-testing procedure is to document the before and after hook throat opening tram point measurement (fig. 3-9). The before measurement is performed before the weight test of the crane.

Sheave Inspection

Sheaves are located in the hook block, boom point, boom bridle, gantry, and boom mast. Sheaves are installed basically anywhere wire rope must turn or bend. Sheaves rotate on either bearings or bushings that are inspected for discoloration (due to excessive heat), metallic particles, chips or displaced

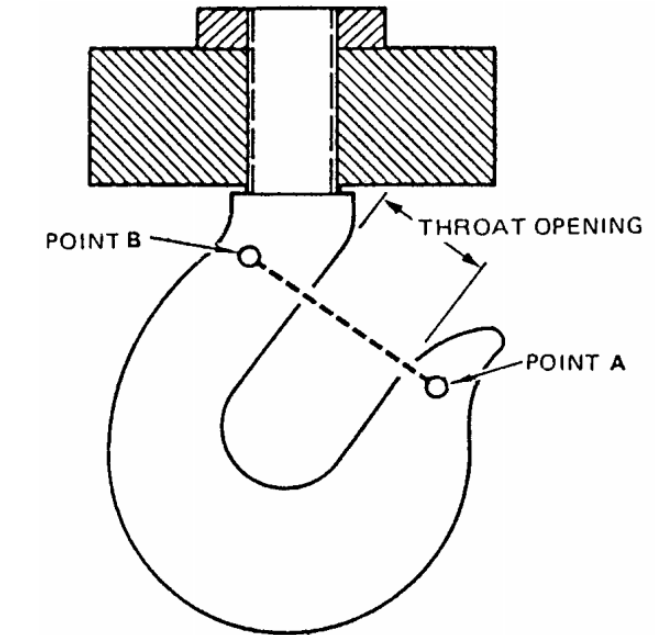

Figure 3-9.-Hook throat measurement.

metal, broken or distorted bearing retainer or seals, adequate lubrication, and tight bearing caps.

The sheave inspection (fig. 3-10) is the inspection for wear and damage, wear in the wire rope sheave groove, loose or damaged sheave guards, and worn bearings and pins.

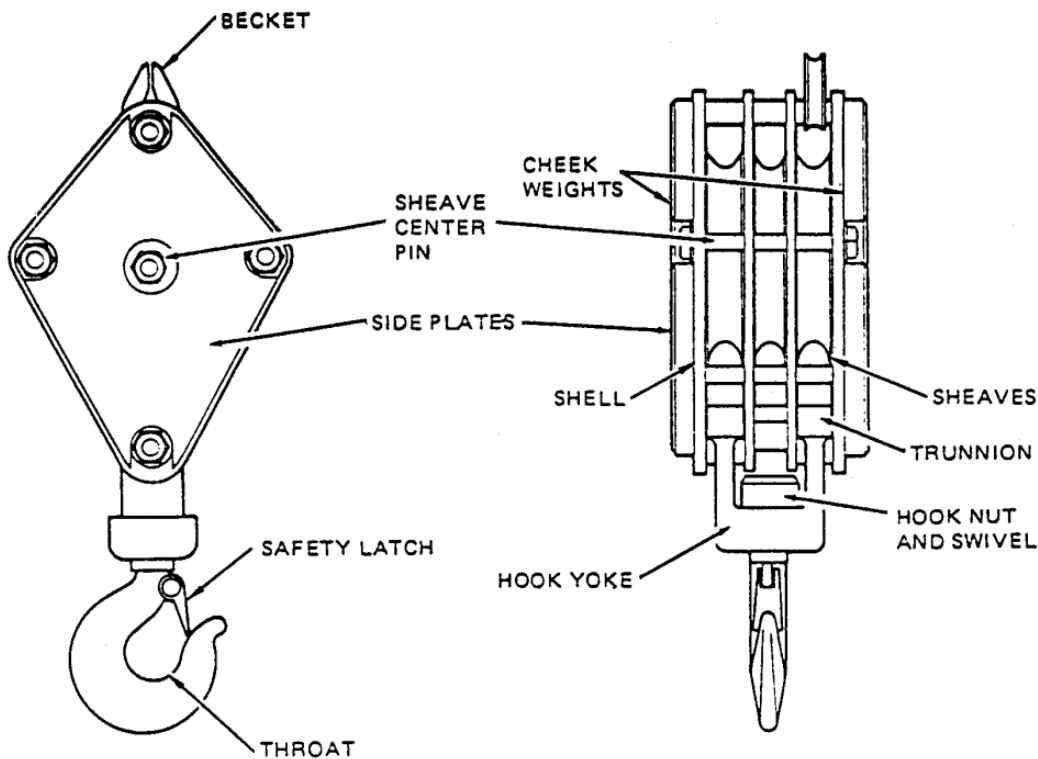
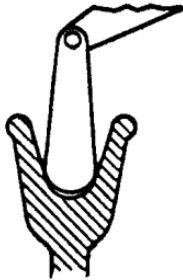

Figure 3-8.—Hook and block inspection points.

A PROPER FITTING SHEAVE GROOVE SHOULD SUPPORT THE ROPE OVER 90-150 DEGREES OF ROPE CIRCUMFERENCE.

IMPROPER



PROPER

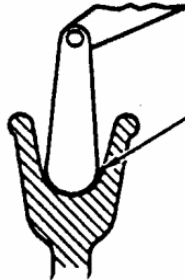

CHECK GROOVES FOR PROPER SIZE.

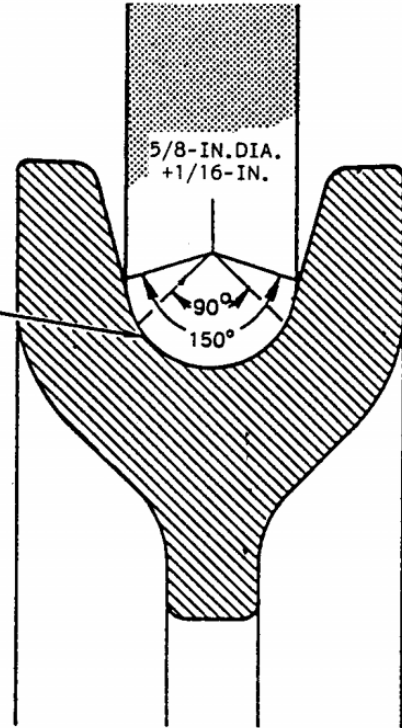

OBSERVE THE GROOVE SO THAT IT MAY BE CLEARLY SEEN WHETHER THE CONTOUR OF THE GAUGE MATCHES THE CONTOUR OF THE BOTTOM OF THE GROOVE.

CHECK FLANGES FOR WEAR, CHIPS, AND CRACKS.

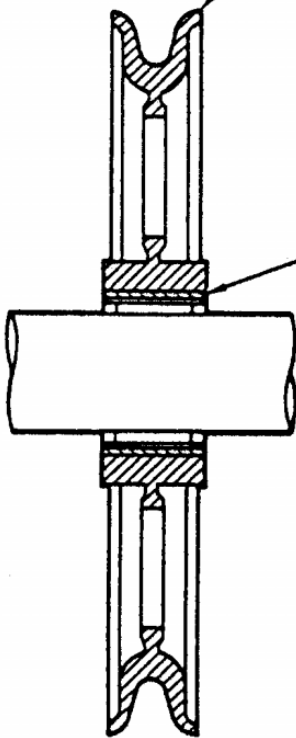

CHECK BEARINGS FOR WOBBLE, LUBRICATION, AND EASE OF ROTATION.

CHECK SHEAVE GROOVES FOR WEAR.

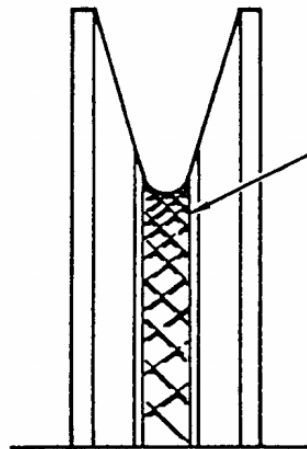

A SHEAVE BADLY CORRUGATED BY THE ROPE'S PRINT, A CONDITION THAT COULD SERIOUSLY DAMAGE THE WIRE ROPE. SHEAVE MUST BE REPLACED.

Figure 3-10.—Sheave (Pulley) Inspection.

MAXIMUM ALLOWABLE LOADS - CRANE SERVICE								
BOOM LENGTH IN FEET	LOAD RADIUS IN FEET	BOOM ANGLE IN DEGREES	BOOM POINT IN HEIGHT	WITH OUTRIGGERS SET*		WITHOUT OUTRIGGERS		
				OVER SIDE	OVER REAR	OVER SIDE		OVER REAR
						8'-0" WIDE	9'-0" WIDE	9' OR 9' WIDE
30	10	78	35'6"	*50,000	*50,000	28,800	32,200	39,300
	12	74	35'0"	*50,000	*50,000	22,500	24,900	30,800
	15	68	34'0"	*50,000	*50,000	16,800	18,500	23,200
	20	57	31'3"	36,800	*43,700	11,700	12,800	16,200
	25	44	27'3"	26,000	31,100	8,800	9,700	12,400
40	12	78	45'3"	*50,000	*50,000	22,200	24,600	30,600
	15	74	44'6"	*50,000	*50,000	16,500	18,200	22,900
	20	66	42'9"	36,600	*41,300	11,400	12,500	16,000
	25	58	40'0"	25,800	30,900	8,600	9,400	12,200
	30	49	36'3"	19,800	23,700	6,800	7,400	9,700
50	35	38	30'9"	15,900	19,100	5,500	6,050	8,000
	15	77	55'0"	*50,000	*50,000	16,400	18,000	22,700
	20	71	53'6"	36,500	*40,000	11,300	12,300	15,800
	25	65	51'6"	25,700	*30,400	8,450	9,250	12,000
	30	58	48'9"	19,600	23,600	6,650	7,250	9,500
60	35	51	45'0"	15,800	19,000	5,400	5,900	7,800
	40	43	40'6"	13,100	16,800	4,500	4,900	6,600
	45	34	34'0"	11,200	13,500	3,800	4,150	5,650
	15	79	65'3"	*48,800	*48,800	16,100	17,800	22,500
	20	74	64'0"	36,400	*39,100	11,000	12,100	15,600
70	25	69	62'3"	25,500	*29,600	8,150	8,950	11,800
	30	64	60'0"	19,500	23,400	6,350	7,000	9,300
	35	59	57'3"	15,600	18,800	5,100	5,650	7,600
	40	53	53'9"	13,000	15,700	4,200	4,650	6,400
	45	46	49'6"	11,000	13,300	3,500	3,900	5,350
80	50	39	44'3"	9,500	11,600	2,950	3,300	4,700
	55	32	37'9"	8,400	10,200	2,500	2,800	4,000
	20	77	74'3"	36,200	*37,300	10,700	11,800	15,400
	25	72	73'0"	25,300	*28,800	7,850	8,700	11,600
	30	68	71'0"	19,300	*23,100	6,100	6,700	9,100
90	40	59	66'0"	12,800	15,500	3,900	4,350	6,200
	50	49	58'6"	9,350	11,400	2,700	3,000	4,500
	60	36	47'6"	7,200	8,850	1,850	2,150	3,350
	20	78	84'6"	*32,800	*32,800			
	25	75	83'3"	23,200	*28,400			
100	30	71	81'9"	19,100	*22,600			
	40	63	77'6"	12,600	15,300			
	50	55	71'3"	9,200	11,200			
	60	45	62'9"	7,050	8,700			
	70	34	50'9"	5,600	6,950			
110	80	80	94'9"	*29,000	*29,000			
	25	77	93'9"	25,100	*26,000			
	30	73	92'3"	19,000	*22,200			
	40	66	88'6"	12,500	15,200			
	50	59	83'3"	9,050	11,000			
100	60	51	76'3"	6,900	8,550			
	70	43	66'9"	5,450	6,800			
	80	32	53'6"	4,400	5,600			
	20	81	105'0"	*25,300	*25,300			
	30	75	102'9"	18,800	*20,500			
110	40	69	99'3"	12,300	15,000			
	50	63	94'9"	8,850	10,800			
	60	56	88'9"	6,700	8,400			
	70	49	81'0"	5,250	6,600			
	80	40	70'6"	4,200	5,350			
110	90	30	56'3"	3,350	4,400			
	20	81	115'0"	*22,000	*22,000			
	30	76	113'0"	*17,700	*17,700			
	40	71	110'0"	12,100	*14,000			
	50	65	106'0"	8,650	10,700			
110	60	59	100'6"	6,500	8,200			
	70	53	93'9"	5,050	6,450			
	80	46	85'3"	4,000	5,200			
	90	38	74'3"	3,200	4,250			
	100	29	59'0"	2,600	3,500			

Figure 3-11.—Typical crane capacity chart.

TEST PROCEDURES

After the crane has been prestared and transported to the test pad, the crane crew supervisors assist the crane test director to set up the weights for the weight-testing procedure. The crane crew supervisors must know the length of boom and the number of parts of line assembled on the crane. When testing cranes, you must test all the sections of boom assigned to a crane during the crane test procedures. The supervisors take the boom length measurement and the number of parts of line and review the load charts (fig. 3-11) to determine the maximum-rated allowable load that the crane can lift. Mobile cranes are weight-tested at 110 percent of the rated capacity. Crawler cranes are weight-tested at 125 percent of the rated capacity. Complete tests are performed on each hook, such as the main hoist and the auxiliary or jib hoist. All rigging used in crane

load testing must have been previously tested to at least 150 percent of the rated working load.

Test Weights

To determine the test weight for a mobile crane, refer to the manufacturer's load charts assigned to the crane. To determine the test weight used in the following example, use the load chart in figure 3-11. When the crane is assembled with 60 feet of boom, the minimum radius noted on the load chart is 15 feet, with a rated capacity of 48,800 pounds. Do not rely on the boom angle indicator for radius accuracy when the lift exceeds 75 percent of the rated capacity; however, check the accuracy of the boom angle indicator by placing a 3-foot builder's level on the center boom section and raise or lower the boom until the level indicates the boom is level (fig. 3-12). At this point the boom angle indicator should show the

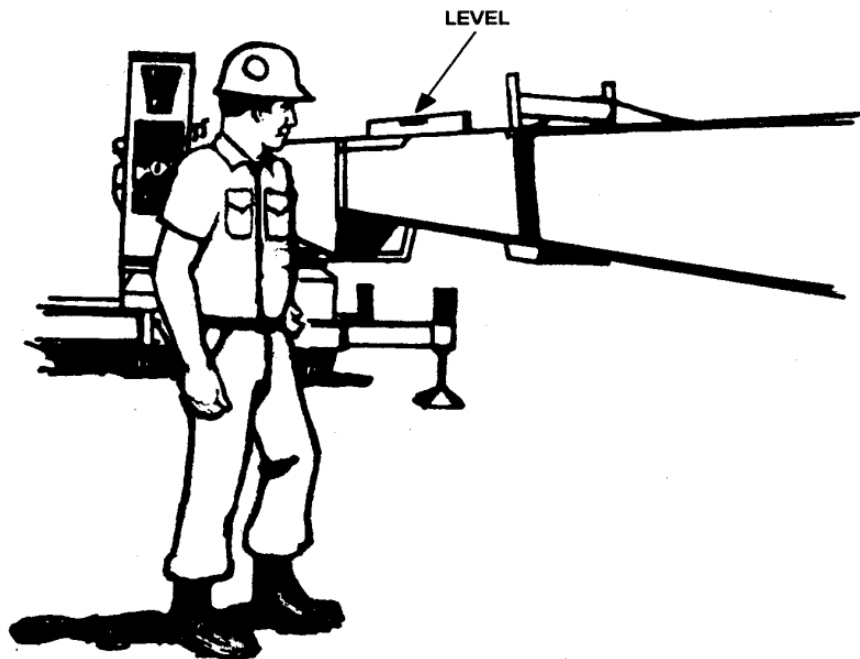
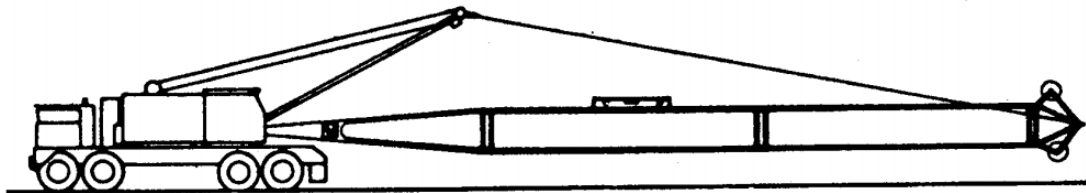

CHECK THE ACCURACY OF THE BOOM ANGLE INDICATOR BY USING A 3' LEVEL.

Figure 3-12.—Check accuracy of boom angle indicator.

boom is at zero degrees or adjusted to read zero degrees. Measure the radius to avoid any possibility of error. Take the 48,800 pounds and multiply it by 110 percent ($48,800 \times 110\%$ or $1.10 = 53,680$). The test weight for this crane example is 53,680 pounds. After the test weight is figured, you must remember that the hook blocks and rigging gear are weight that are part of the test weight.

The number of parts of line rigged on the crane is important (fig. 3-13). Most load charts will have the rated capacity of the crane for different parts of the line; for example, a crane that is capable of being rigged with a eight-part line is rigged with a six-part line. Check the load chart for the six-part line capacity; take that rated capacity and multiply it by 110 percent. The answer will be your test weight.

Another weight to figure is the weight for the stability test. The stability test requires that the maximum test load be lifted first at the maximum radius and then be swung through each manufacturer's recommended quadrant of

operation for the crane, which is normally over the side and rear. Using the load chart (fig. 3-11) with the crane assembled with 60 feet of boom, the maximum radius is 55 feet. Note on the load chart a rated capacity for over the rear and over the side. Since the weight has to be transferred from one quadrant to the other as part of the test procedure, use the recommended capacity for over the side. You will find on some load charts the rated capacity will be the same for over the side and rear. The rated capacity for this example is 8,400 pounds. Multiply the 8,400 by 110 percent (1.10). ($8,400 \times 1.10 = 9,240$.) In this case, the stability test weight is 9,240 pounds. After the test weight is figured, you must remember that the hook blocks and rigging gear are weight that are part of the test weight.

A third test weight to compute is the test weight for the auxiliary line, commonly known as the whip line. This test weight is computed by the maximum load capacity for the winch hoist or the safe working load (SWL) of the wire rope installed on the winch. You must remember that when the winch capacity is

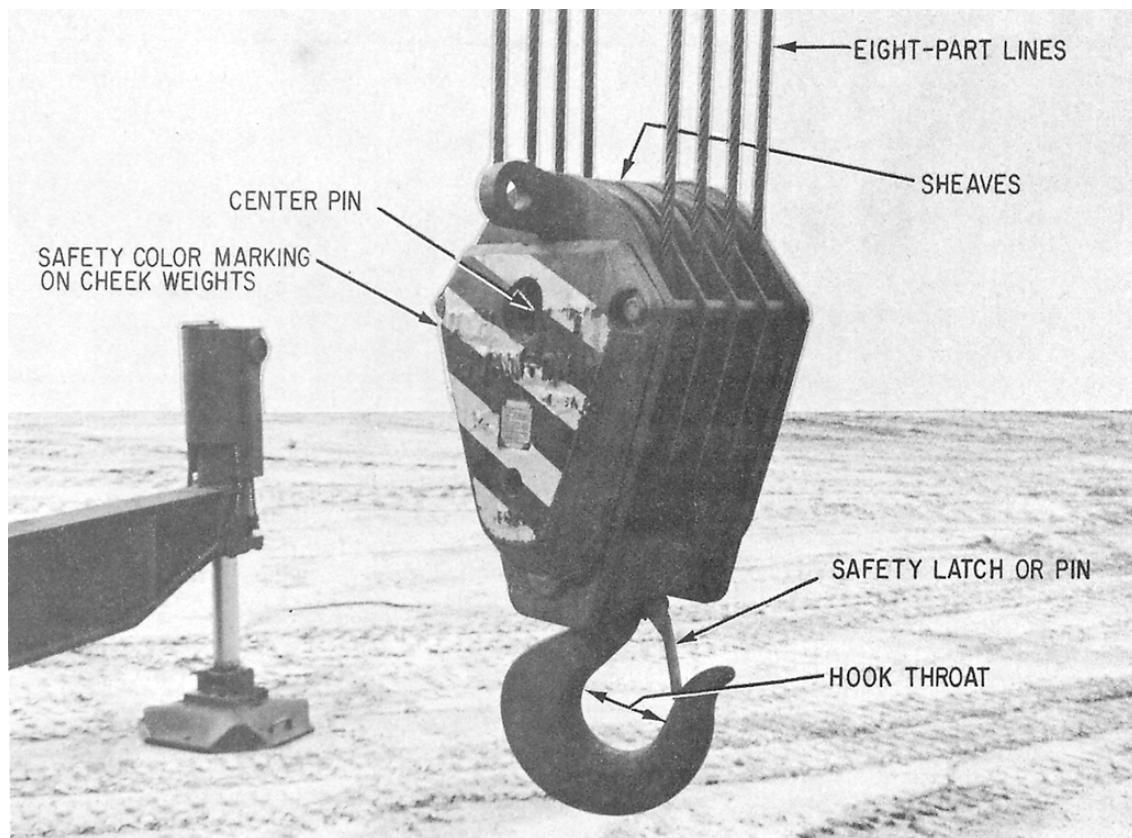

Figure 3-13.—Eight-part line hook block.

greater than the SWL of the wire rope, the test weight will be computed from the SWL of the wire rope or if the winch capacity is less than the SWL of the wire rope, the test weight will be computed from the capacity of the winch. The winch capacity is either documented on the load charts or in the manufacturer's manual.

The formula for computing the SWL for a hoist rope is the diameter of the rope squared multiplied by 8 or $(D \times D \times 8 = \text{SWL in tons})$.

Example: The wire rope on a crane is 1/2 inch in diameter. Compute the SWL for the rope.

The first step is to convert the 1/2 into a decimal number by dividing the bottom number of the fraction into the top number of the fraction: (1 divided by 2 = .5). Next, compute the SWL formula: $(.5 \times .5 \times 8 = 2 \text{ tons})$. The SWL of the 1/2-inch wire rope is 2 tons.

The next factor to compute is the breaking strength of the wire rope. On some wire rope spools, the nominal breaking strength of the wire rope is published; however, if the breaking strength is unknown, a break test can be performed on the wire rope. This is accomplished by cutting off sections of the wire rope and placing each section of the rope on a wire rope break test machine. The machine pulls the wire rope apart and computes the breaking strength. By testing several sections of the wire rope, you can determine the average breaking strength for that type of wire rope. Overseas, Public Works Centers normally have wire rope break test machines that can be used by the NCF. If the break test cannot be performed, the rule of thumb used for finding the breaking strength is to multiply the SWL by 5 $(\text{SWL} \times 5 = \text{B.S.})$. For example, a 1/2-inch wire rope with a SWL of 2 tons has a breaking strength of 10 tons $(2 \times 5 = 10 \text{ tons})$. REMEMBER: When the single line wire rope end connection is assembled with a wedge socket, the wedge socket only develops 70 percent of the breaking strength. Example: The crane is rigged with 1/2-inch wire rope with a wedge socket end connection. The wedge socket only develops seventy percent of the 1/2-inch wire rope B.S. of 10 tons, which gives the wire rope a B.S. determined by an end connection of 7 tons. Swaged socket, cappel socket, and the zinc (spelter) socket all provide 100 percent of the breaking strength when properly made.

The next factor to compute is the AWL by using the factor of safety (F.S.). To compute the allowable

working load (AWL) of a wire rope, you must first understand the following wire rope safety factors:

1. Rigging rope
 - a. 5 to 1 under operating conditions
 - b. 10 to 1 when used to lift personnel
2. Pendants or standing rope
 - a. 3.0 to 1 under operating conditions
 - b. 2.5 to 1 when erecting the boom
3. Ropes that wind on drums or pass over sheaves
 - a. 3.5 to 1 under operating conditions
 - b. 3.0 to 1 when erecting the boom

For the auxiliary line, use the F.S. of 3.5 for wire rope that winds on drums or passes over sheaves. The formula for the F.S. is the breaking strength (B.S.), determined by the type of end connection divided by F.S. (Example: $\text{B.S.} = 7$ divided by 3.5 = AWL of 2 tons.)

The next factor to compute is the test weight. This is done by multiplying the AWL of 2 tons by 110 percent $(2 \times 110\% \text{ or } 2 \times 1.10 = 2.2 \text{ tons})$. Your test weight for the 1/2-inch wire rope is 2.2 tons. After the test weight is figured, you must remember that the hook blocks and rigging gear are weight that are part of the test weight.

Leveling a crane cannot be overemphasized. Cranes must be set up as per manufacturer's instruction, with the outriggers fully extended and the crane leveled. Crane capacity is lost when the crane is out of level by a few degrees (fig. 3-14). Most

Boom Length and Lift Radius	Chart Capacity Lost When Crane Out of Level By		
	1°	2°	3°
Short Boom, Minimum Radius	10%	20%	30%
Short Boom, Maximum Radius	8%	15%	20%
Long Boom, Minimum Radius	30%	41%	50%
Long Boom, Maximum Radius	5%	19%	15%

Figure 3-14.-Crane capacity lost by crane out of level.

cranes have levels mounted on them, but the levels are not always accurate. Use a 3-foot builder's level to check the level of the crane over the rear and over the sides (fig. 3-15).

After the test weights are figured, you must remember that the hook blocks and rigging gear are weight that are part of the test weight. The maximum test weight for this example is set up at the 15-foot radius measurement over the side of the crane. Crane radius is the measurement from the center of rotation to the center of the hook (fig. 3-16).

The crane is weight-tested with the boom rotated ninety (90) degrees from the longitudinal axis of the crane carrier. It is strongly recommended by NAVFAC P-307 that precautions, such as attaching guy wires to the mane or placing cribbing under the counterweight, be used to preclude possible overturning of the crane in the event of wire rope or mechanical failure. Cribbing is normally used in the NCF.

Before testing of the crane can proceed, the crane test mechanic and the certifying officer must be present at the test site. The crane test mechanic and the crane test director will perform and complete the BDA inspection during and after the testing of the crane. This document must be signed by the test mechanic and test director.

One purpose of weight testing the crane is to check and make sure the hydraulic rams on the outriggers support the crane and the maximum lifted load. A way to check the hydraulic rams is with a grease pencil and a ruler. Measure from a known vertical point on the hydraulic ram housing and place a line with the grease pencil on the ram (fig. 3-17).

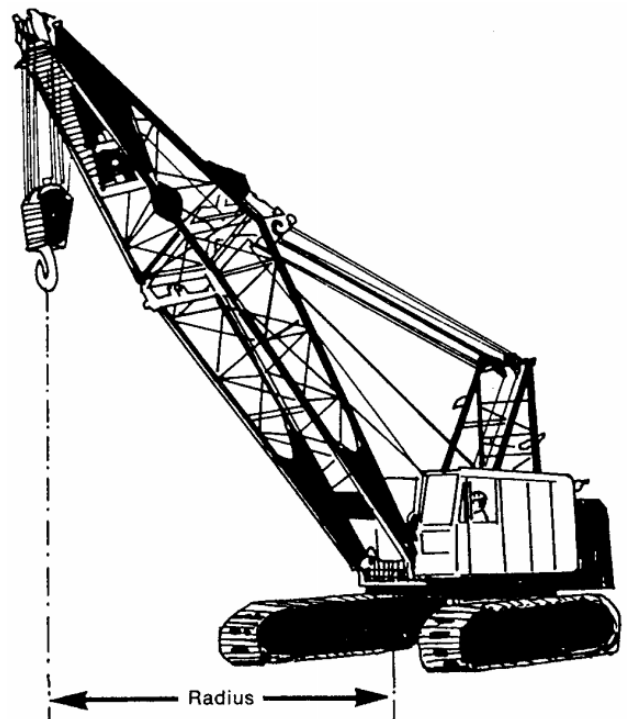

The radius is always measured from the center of rotation and is the radius measured after the boom deflects forward when under load

Figure 3-16.—Crane radius.

After each test, measure this known measurement, and this will enable you to make sure there is no slippage in the hydraulic system.

5.4 No-Load Test

The first part of the crane test procedure is the no-load test. The procedure is as follows:

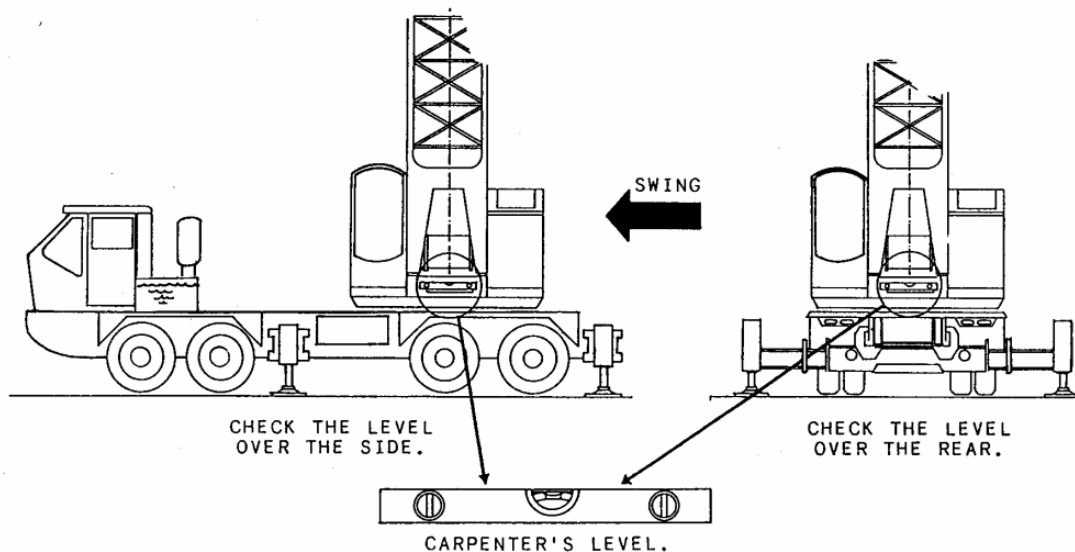

Figure 3-15.—Builder's level leveling procedures.

5.4.1 Hoist.

1. Raise and lower the hook through the full-working distance of hook travel.
2. Run the hoist block into the limit switch or switches, if installed, at slow speed.
3. Run the hoist block beyond the limit switch or switches by using the bypass switch.

5.4.2 Boom.

1. Raise and lower the boom through the full-working range.
2. Raise the boom into the upper limit switch (when installed). Raise the boom past the boom upper limit switch using the bypass switch.
3. Test the lower limit switch (when installed) by the same procedure prescribed for testing the upper limit switch.
4. Extend and retract telescoping boom sections their full distance of travel.
5. Check the radius indicator by measuring the radius at the minimum and maximum boom angle.

5.4.3 Motion.

Other motions, including swing, shall be operated through one cycle (one-full revolution of major components).

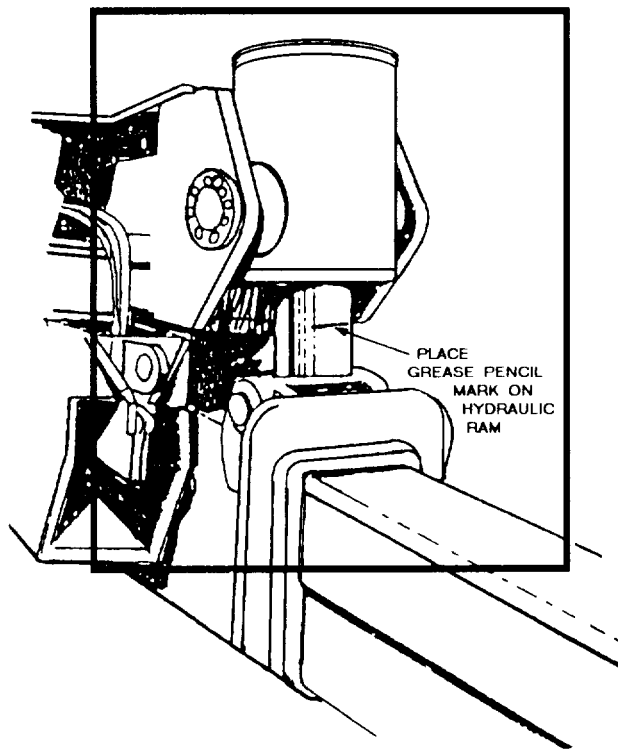

Figure 3-17.—Marking hydraulic rams.

5.5 Load Test

The load test consists of basically two parts: a maximum load test and a stability test. The following test sequence is time and cost effective. The sequence may be varied by the activity.

5.5.1 Maximum Test Load for the Crane on Main Hoist.

1. Static Test. Raise the test load to clear the ground with the boom at minimum radius and hold for 10 minutes without boom and load hoist pawls (dog) engaged. Rotate the load and hook to check bearing operation. Observe any lowering that may occur that may indicate a malfunction of the boom or hoisting components, brakes, or outriggers. For hydraulic cranes, tests are performed with the boom fully retracted and fully extended.

2. Dynamic Test. Raise and lower the test load at normal operating speeds. Lower the test load to the ground until the hoist lines are slack. Wait 5 minutes, hoist test load, and continue on with the test.

3. Hoist Brake. Test the ability of the brake to control and stop the load (fig. 3-18). Test the ability of the brake to hold and lower the test load with the friction clutch disengaged, if applicable.

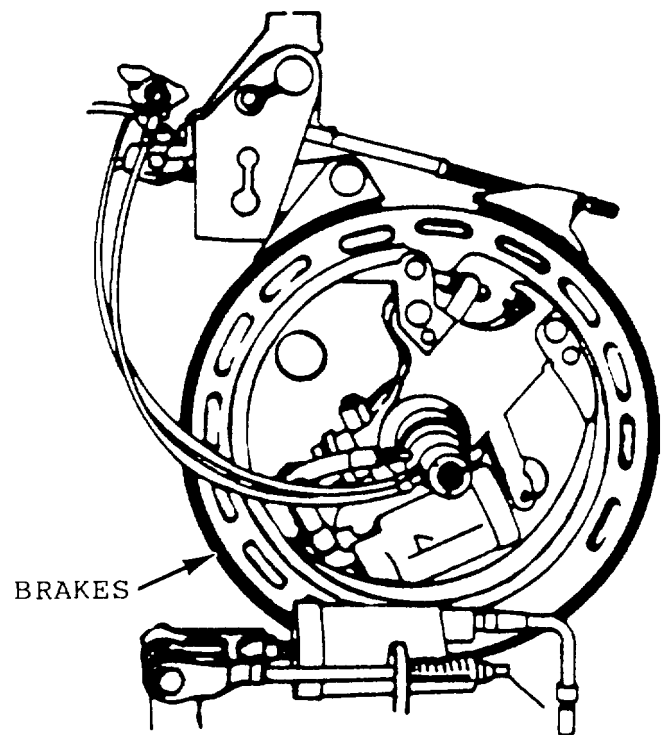

Figure 3-18.—Hoist brake.

4. Boom Operation. Operate the boom from minimum radius to maximum radius for the load applied.

5. Hydraulic Crane Slippage. Lift the test load at maximum radius and allow time for fluid and component temperatures to stabilize. Hold the load for 10 minutes without the operator using the controls. There should be no significant lowering of the load, boom, or outrigger beam due to a component or system malfunction or failure during the test. The significance of any lowering shall be evaluated by the certifying officer, depending on operating requirements and safety.

5.5.2 Maximum Test Load at Maximum Radius of Crane (Stability Test)

1. Boom Operation. Raise and lower the boom through the full-working range. Visually observe for smooth operation. Test the boom brake for proper operation. For hydraulic cranes, the test is performed with the boom fully retracted and fully extended.

2. Rotation. Rotate the crane left and right the maximum degrees allowed by the manufacturer at slow speed. Apply the brake periodically during rotation. The brake should have the ability to stop the rotating motion in a smooth, positive manner.

NOTE: Where brakes are designed for holding only, operate controls (plugging) to stop rotation then apply brakes. Test shall be performed with boom fully retracted and fully extended.

3. Hydraulic Crane Slippage. Lift the test load at maximum radius and allow time for fluid and component temperatures to stabilize. Hold the load for 10 minutes without the operator using the controls. There should be no significant lowering of the load, boom, or outrigger beams due to a component or system malfunction or failure during the test. The significance of any lowering shall be evaluated by the certifying officer, depending on operating requirements and safety.

5.5.3 Auxiliary and Jib Hoist.

The test load should be the maximum load for the hoist.

1. Static Test. Raise the test load to clear the ground and hold for 10 minutes. Observe any lowering that occurs that may indicate a malfunction of the hoisting components or brakes.

2. Dynamic Test. Raise and lower the test load at normal operating speeds. Lower the test load to the ground until the hoist lines are slack. Wait 5 minutes, hoist the test load, and continue the test.

3. Hoist Brake Test. Test the ability of the brake to control and stop the load. Next, test the ability of the brake to hold and lower the test load with the friction clutch disengaged, if applicable.

5.5.4 Free-Rated Load Test.

To check the stability of the crane and operation of the crane carrier, wheels, tires, tracks, brakes, and so forth, under load. Retract outriggers before beginning the free-rated test.

CAUTION

ATTACH TAG LINES TO THE LOAD TO CONTROL OSCILLATION.

NOTE: No static test is required (not applicable to mobile cranes temporarily mounted on barge).

1. Hoist the maximum free-rated test load at the maximum radius over the rear.

a. Rotate the load through the “over the rear” working arc.

b. Travel a minimum of 50 feet with the test load held over the rear of the crane with the boom parallel to the longitudinal axis of the crane carrier.

2. Hoist the maximum free-rated test load at the maximum radius over the side.

a. Rotate the load through the full-working range.

b. Travel a minimum of 50 feet with the test load over the left and then the right side of the crane carrier with the boom 90 degrees to the axis of travel.

As outlined in the COMSECOND/COM-THIRDNCBINST 11200.1 series, rated free loads or pick and carry operations are only performed according to NAVFAC P-307 during a certification, in case of an emergency, or as directed by the crane certifying officer.

5.5.5 Test After Change or Repair of Tires.

After change or repair of tires, the crane should be tested with the maximum free-rated test load over the affected tire(s). Raise and hold the test load for 10 minutes while observing the changed or repaired tire(s).

5.6 Weight-Handling Equipment Used for Other Than Lift Crane Service.

Locomotive, crawler, truck, and cruiser cranes used for clamshell, dragline, magnet, pile driving, or other nonlift crane work should be tested at the

maximum safe working load permitted for the size wire rope being used. This test should be performed in all working motions except travel. Buckets, magnets, and so forth, may be removed for testing wire rope. No test is required after reassembly. Retesting is not required when the end attachment is changed from the original connection (that is, changed from clamshell use to dragline, and so on) during the certification period.

Upon successful completion of the inspection and load test, the certification of the load test and condition inspection (fig. 3-19) must be prepared in triplicate. The following items are documented on this form:

Load Test Certification

After the test, the crane test mechanic and the crane test director will jointly perform an after inspection of the crane. This inspection is documented on the Crane Condition Inspection Record.

1. USN number of the crane
2. Type of crane
3. Rated capacity of the crane
4. Boom length of the crane
5. Location
6. Test date
7. Reason for test

Crane No. 82-00001	Type P&H	Rated Cap lbs. 48800 feet 15'	Boom Length 60	Location CAMP COVINGTON, GUAM	Test Date 5-26-92
Reason for Test ANNUAL CERTIFICATION			Certification This is to certify that inspections and tests have been conducted in accordance with the crane test procedures set forth in the current Naval Facilities Engineering Command P-307, Volume 1		
Category 1 Cranes					
Hoist	Test Load %	Minimum Radius		Maximum Radius	
		Pounds	Feet	Pounds	Feet
Main	110	53680	15	9240	55
Aux	110	4400	—	—	—
Whip	NA	—	—	—	—
Hook Throat Opening		Before Test		After Test	
Main Hook		4 7/64		4 7/64	
Aux Hook		3 1/64		3 1/64	
Whip Hook					
Category 2 Cranes					
Hoist	Test Load %	Minimum Radius		Maximum Radius	
		Pounds	Feet	Pounds	Feet
Main					
Aux					
Hook Throat Opening		Before Test		After Test	
Main Hook					
Aux Hook					
Category 3 Cranes					
Hoist	Test Load %	Hook Throat Opening			
		Pounds	Feet	Before Test	After Test
Main					
Aux					
Crane Condition Inspection Record Item Numbers					
Check (✓) items inspected					
1 ✓	6 ✓	11 ✓	16 ✓	21 ✓	26 ✓
2 ✓	7 ✓	12 ✓	17 ✓	22 ✓	27 ✓
3 ✓	8 ✓	13 ✓	18 ✓	23 ✓	28 ✓
4 ✓	9 ✓	14 ✓	19 ✓	24 ✓	29 ✓
5 ✓	10 ✓	15 ✓	20 ✓	25 NA	30 ✓
				31 ✓	35 NA
				32 ✓	37 NA
				33 ✓	38 NA
				34 NA	39 NA
				35 NA	40 NA
It is further certified that the crane identified above is satisfactory to lift its rated capacity at its rated load.					
Remarks: NA					
Test Director (Signature) Walter T. Doan				Date 5-26-92	
Inspector (Signature) Jack R. Frost				Date 5-26-92	
Certifying Official (Signature) Able B. Swann				Date 5-26-92	

Figure 3-19.—Certification of Load Test and Condition Inspection.

8. Hook tram point measurements (before and after measurements)
9. Test weights lifted
10. Crane condition inspection record item numbers inspected
11. Test procedures paragraph numbers performed, as outlined in NAVFAC P-307

The memorandum must be signed by the test director, the mechanical inspector, and the certifying officer. The original is filed in the appropriate equipment history jacket. One copy is filed in the unit safety office, and the second copy is kept in an accessible protected container on the crane. The certification date is stenciled with 3-inch stencils on the operator's side of the revolving house.

Frequency of Test

The command schedules each crane for periodic condition and load tests. Tests are conducted before placing any crane into initial use. Cranes stored or idle for 6 months or more must be inspected and tested before returning to service. ANY MACHINE THAT HAS HAD MAJOR REPAIRS OR REPLACEMENT OF LOAD BEARING OR CONTROLLING PARTS WILL ALSO BE TESTED BEFORE IT IS PUT BACK IN SERVICE. The definitions of load bearing and controlling are only those parts and components that support the load and whose failure would result in uncontrolled dropping, shifting, or moving of the load. Tests may be conducted as frequently as local authorities deem advisable (not to exceed 12 months between tests).

After the crane has passed the test procedures, the mechanics will place the NMCB unit identification marking decal on the crane in the correct locations.

Extension of Certification

The commanding officer may approve in writing a temporary extension of the prior annual certification when an emergent or other contingent conditions exist precluding the timely certification of the crane. The authority to extend certifications cannot be delegated. Before you extend the certification, the crane must pass a complete condition inspection.

CRANE SAFETY

Loss in terms of lives, injuries, and equipment can be decreased with positive action and the use of safe

operating techniques by all Seabees working on or around cranes.

Stability

Most crane mishaps result from operator error. Setting up for the lift is the most critical portion of the crane operation. The most common causes of mishaps are as follows:

1. Failure to block/crib under the outriggers pads where poor ground conditions would not support the total weight of the crane and load.
2. Failure to extend the outriggers fully and use it following the manufacturer's instructions.
3. Failure to note overhead obstructions, such as overpasses and power lines.
4. Failure to level the crane.

Load Capacity

The rated capacities of mobile cranes are based on both strength and stability. Manufacturers of cranes will normally denote on the load charts a shaded area or a bold line across the chart dividing the lifting capacities based on strength or stability of the crane. It is extremely important to know the difference for, in one case, one of the structural components of the crane will break, and in the other case, the crane will tip over. The following factors must also be recognized and the capacity adjusted accordingly:

1. Do not use stability to determine lifting capacity. Use the load chart installed by the crane manufacturer. The load chart is securely attached in the operator's cab.
2. Recommended parts of hoist reeving and the recommended size and type of wire rope for various crane loads.
3. Length of boom.
4. Boom angle.
5. Boom pendant angle (when the telescopic/folding gantry is down, the angle decreases and the stress increases).
6. Gantry and/or live mast in the highest position.
7. Quadrant of operation (that is, over the side, over the rear capacities).

CAUTION

DO NOT RELY ON THE BOOM ANGLE INDICATOR FOR RADIUS ACCURACY WHEN LIFTS EXCEED 75 PERCENT OF THE RATED CAPACITY. MEASURE TO AVOID THE POSSIBILITY OF ERROR.

NOTE: Capacity charts do not apply if the machine has been modified in any way. Rated capacity is based on the machine as it was originally manufactured and equipped.

Safe Lifting

The following factors will give you some basic guidelines of what you must know to perform safe daily crane operations:

1. Determine the weight to be lifted and the crane required to make the lift safely.
2. Travel the proposed route the crane will follow to and from the project site, and complete the Crane Lift Checklist.
3. Obtain the travel permits if required.
4. Brief operators and riggers on the specifics of the lift and travel conditions.
5. Inspect the crane area setup for stability and safe operating area.
6. Fully extend the outriggers and use them according to the manufacturer's instructions.
7. Check the machine for levelness.
8. Inspect slings, spreader bars, and all other hardware being used.
9. Select the proper sling with sufficient capacity rating.
10. Center the sling in the base (bowl) of the hook to avoid hook point loading, and ensure that the hook block is always placed over the center of the load to eliminate shock loading of the slings or cranes resulting from load shifts when a lift is made.
11. Make ample safety allowances for unknown factors.
12. Stand clear of and do not walk under suspended loads.
13. Boom deflection. All crane booms have deflection. When the load is lifted off the

ground, the boom will deflect causing the radius to increase. Increased radius may cause overloading of the crane.

14. Clean operating area. Water coolers, excess tools, grease, soda cans, and other unnecessary items should be located outside the operating area of the crane. Water coolers must be kept off the crane to prevent people from walking around the crane when in operation.
15. Weight on outriggers. On lattice booms, about 60 percent of the load is on the outriggers close to the load. On hydraulic cranes during near capacity lifts at high boom angles, about 60 percent of the load is on outriggers away from the load.

ATTENTION: SAFE LIFTING IS PARAMOUNT! PROJECT COMPLETION MUST NOT INTERFERE WITH SAFE CRANE OPERATIONS!

Training

For deployed units, COMSECOND/COMTHIRDNCBINST 11200.1 series requires biweekly crane operation and safety meetings be conducted. The meetings review crane operations and include general safety, minimum rigging procedures, crane and rigging responsibilities, and upcoming lifts. The Alfa company commander, crane test director, crane supervisor and operators/riggers should attend the meetings.

Mishap Reporting

In addition to the requirements outlined in COMSECOND/COMTHIRDNCBINST 5100.1 series, any mishap involving NCF cranes must be reported by message to the COMTHIRDNCB DET, Port Hueneme, California, or the COMSECONDNCB DET, Gulfport, Mississippi.

WIRE ROPE SLINGS AND RIGGING HARDWARE

The use of slings, hooks, spreader bars, shackles, and so forth, for lifting is a vital link in the weight-handling process. An in-depth management program for the maintenance and use of slings is required to ensure the entire weight-handling operations are performed safely and professionally. The crane crew supervisors are responsible for the

inspection and turnover of all slings and rigging gear during the BEEP.

Slings

Wire rope slings require special attention due to being subjected to severe wear, abrasion, impact loading, crushing, kinking, and overloading. Failure to provide blocking or protective pads permits sharp corners to cut into the sling. Pulling slings from under loads results in abrasion and kinking. Dropping loads on slings or running equipment over slings will cause crushing. Sudden starts and stops when lifting loads will increase stress on the sling. The recommended factor of safety for wire rope slings is 5:1 due to the severe service expended on slings, errors made in determining load weights, and the effects of sling stress from sling angles (fig. 3-20).

Single-Vertical Hitch

The single-vertical hitch (fig. 3-21) is a sling that supports a load by a single vertical part or leg of the

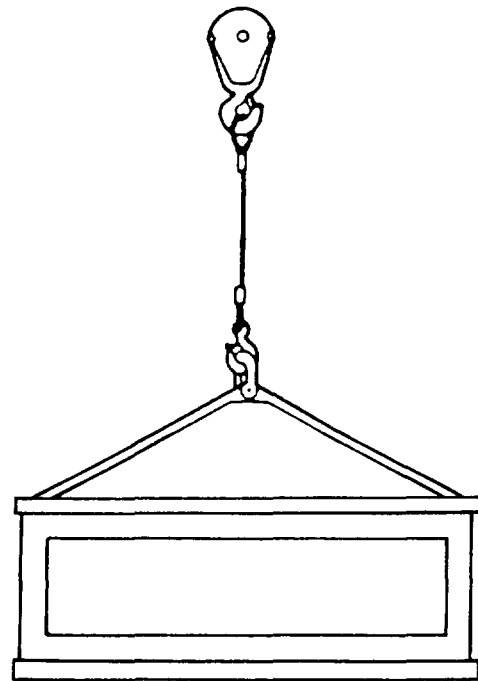

Figure 3-21.-Single-vertical hitch.

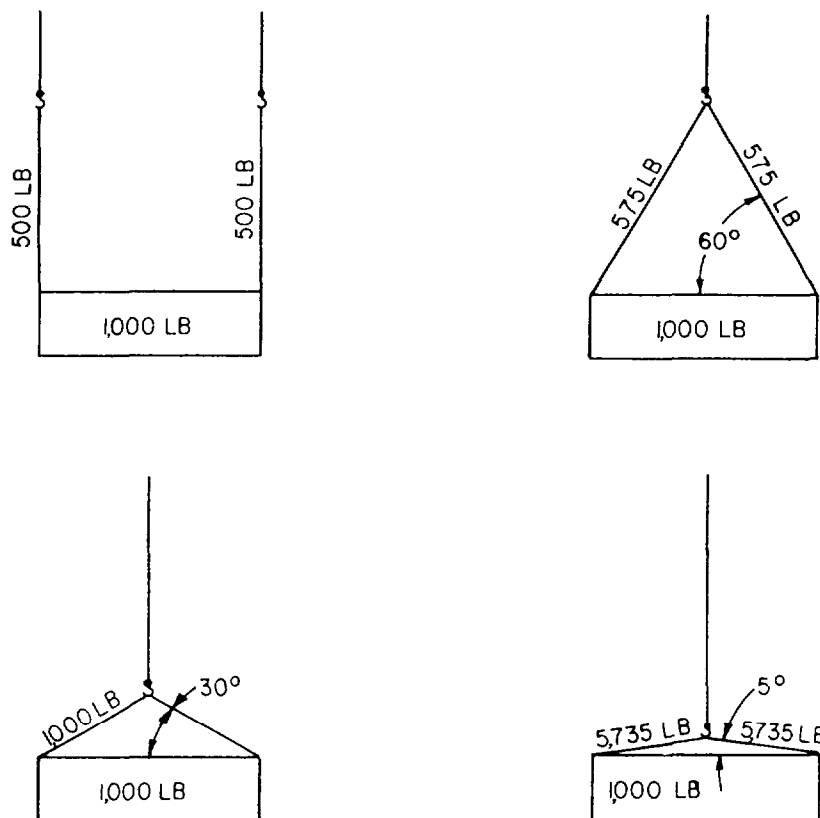

Figure 3-20.-Sling stress.

sling. The total weight of the load is carried by a single leg with the sling angle of 90 degrees.

Bridle Hitch

The bridle hitch can consist of two, three, or four single hitches (fig. 3-22), used together to form a bridle hitch for hoisting an object.

The bridle hitch provides excellent load stability when the load is distributed equally among the legs, the load hook is directly over the center of gravity of the load, and the load is raised level. The use of a bridle sling requires that the sling angles be carefully determined to ensure that the individual legs are not overloaded. It is wrong to conclude that a three- or four-leg bridle hitch will safely lift a load equal to the safe load on one leg multiplied by the number of legs, because there is no way of knowing that each leg is carrying its share of the load. With a four-legged bridle sling lifting a rigid load, it is possible for two of the legs to take practically the full load while the other two only balance it. COMSECOND/COMTHIRDNCB strongly recommend that the rated capacities for two-leg bridle slings listed in the COMSECOND/COMTHIRDNCBINST 11200.11 series be used also as the safe load of three- or four-leg bridle hitches.

Sling Angle

The rated capacity of any sling depends on the size, the configuration, and the angles formed by the legs of the sling and the horizontal. A sling with two legs used to lift a 1,000 pound object will have 500 pounds of the load on each leg when the sling angle is 90 degrees. The load stress on each leg increases as the angle decreases; and if the sling angle was 30 degrees lifting the same 1,000 pound object, the load will be 1,000 pounds on each leg. Try to keep all sling angles greater than 45 degrees; sling angles approaching 30 degrees are considered extremely hazardous and must be avoided at all cost.

Sling Safe Working Loads

It is a difficult task to remember all of the load, size, and sling combinations; however, the following

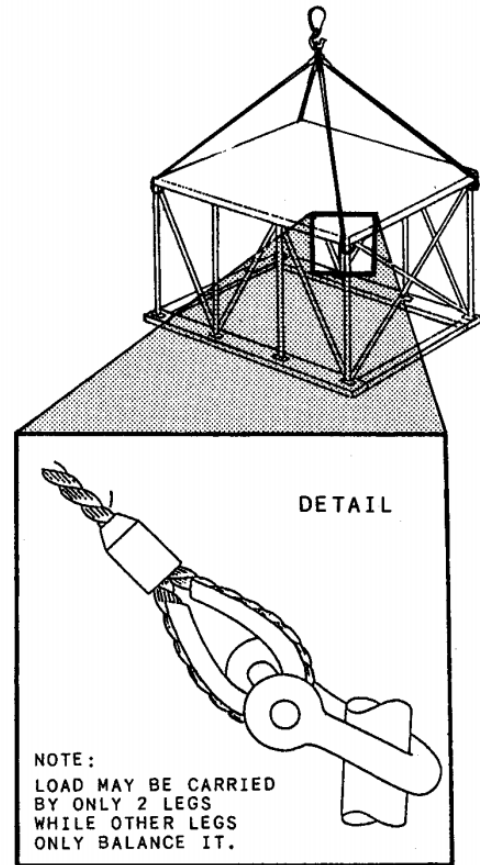
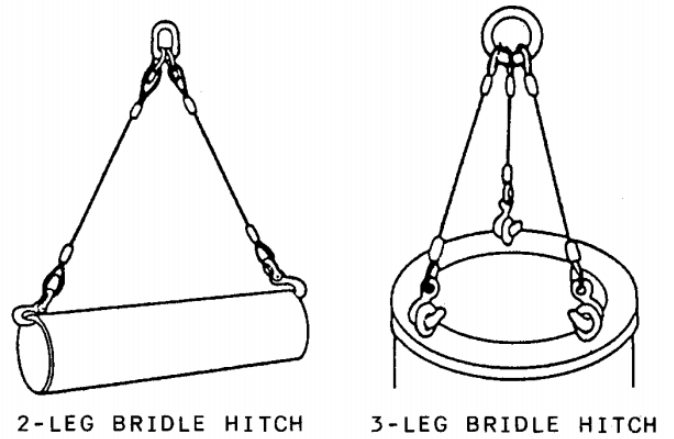

4-LEG BRIDLE HITCH

Figure 3-22.—Bridle hitch.

rules of thumb work well for estimating the loads in the most sling configurations.

The rules of thumb are based on the safe working load of the single vertical hitch of a particular sling. The efficiencies of the end fittings used also have to be considered when determining the capacity of the combination.

The formula used to compute the safe working load (SWL) for a bridle hitch with two, three, or four legs (fig. 3-23) is $SWL \text{ (of single vertical hitch)} \times H \text{ (Height)} \div L \text{ (Length)} \times 2 = SWL$. When the sling legs are not of equal length, use the smallest H/L measurement. This formula is for a two-leg bridle hitch but it is strongly recommended it also be used for the three- and four-leg hitches.

However, do not forget it is wrong to assume that a three- or four-leg hitch will safely lift a load equal to the safe load on one leg multiplied by the number of legs.

Other formulas are as follows:

Single-Basket Hitch (fig. 3-24): For vertical legs, $SWL = SWL \text{ (of single-vertical hitch)} \times 2$.

For inclined legs, $SWL = SWL \text{ (of single-vertical hitch)} \times H \text{ divided by } L \times 4$.

Double-Basket Hitch (fig. 3-25): For vertical legs, $SWL = SWL \text{ (of single-vertical hitch)} \times 4$.

For inclined legs, $SWL = SWL \text{ (of single-vertical hitch)} \times H \text{ divided by } L \times 8$.

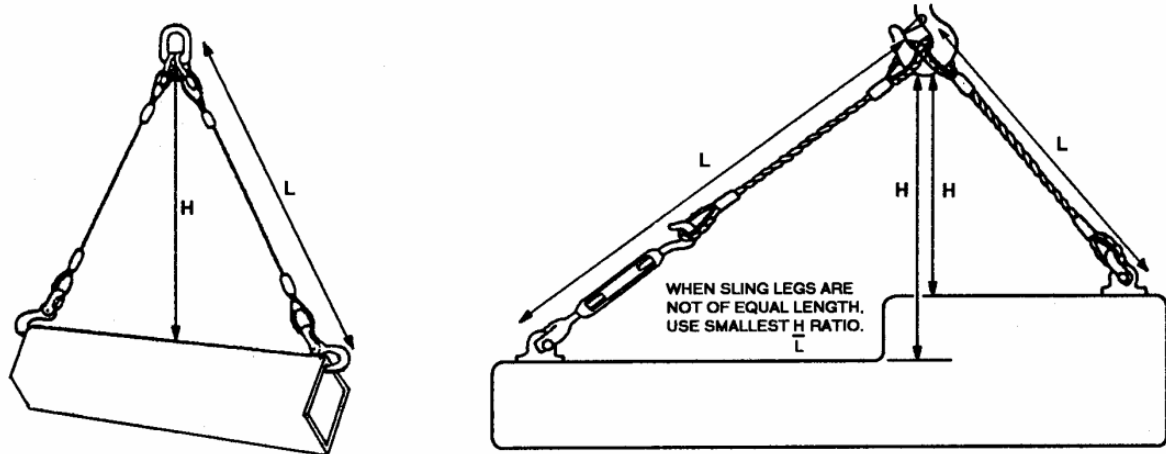

2 - LEG BRIDLE HITCHES

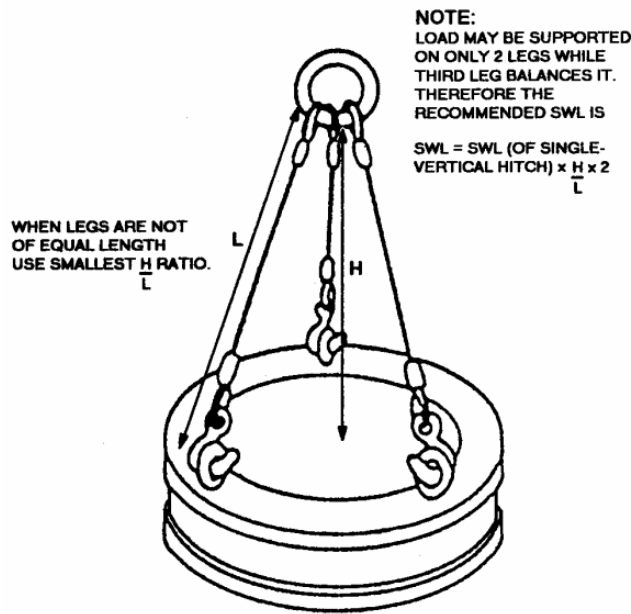

3 - LEG

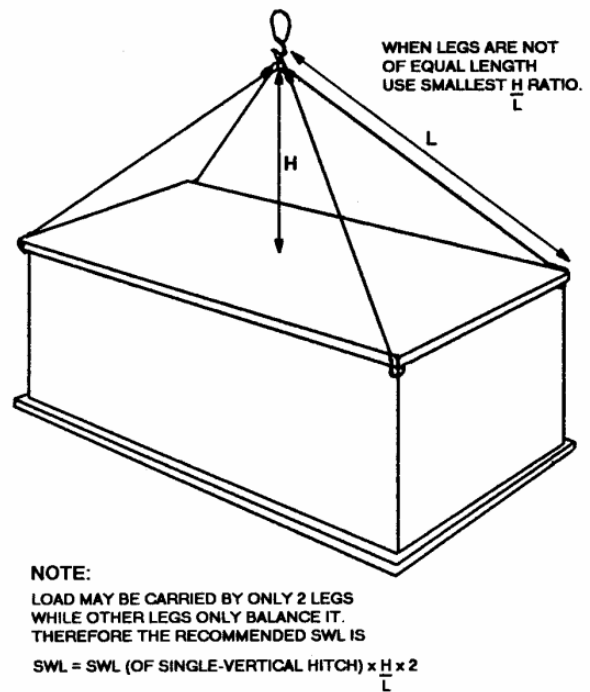

4 - LEG

Figure 3-23.—Determination of bridle hitch sling capacity.

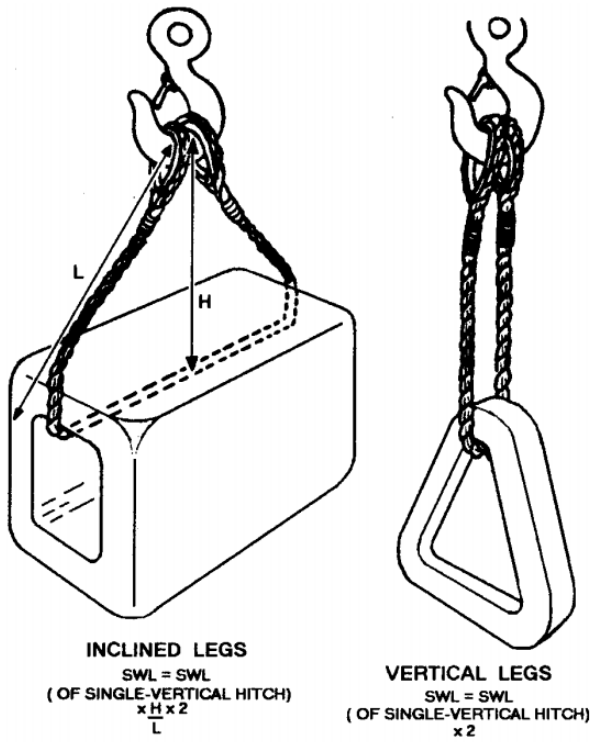

Figure 3-24.—Determination of single-basket hitch sling capacity.

Single-Choker Hitch (fig. 3-26): For sling angles of 45 degrees or more, $SWL = SWL$ (of single-vertical hitch) $\times 3/4$ or .75.

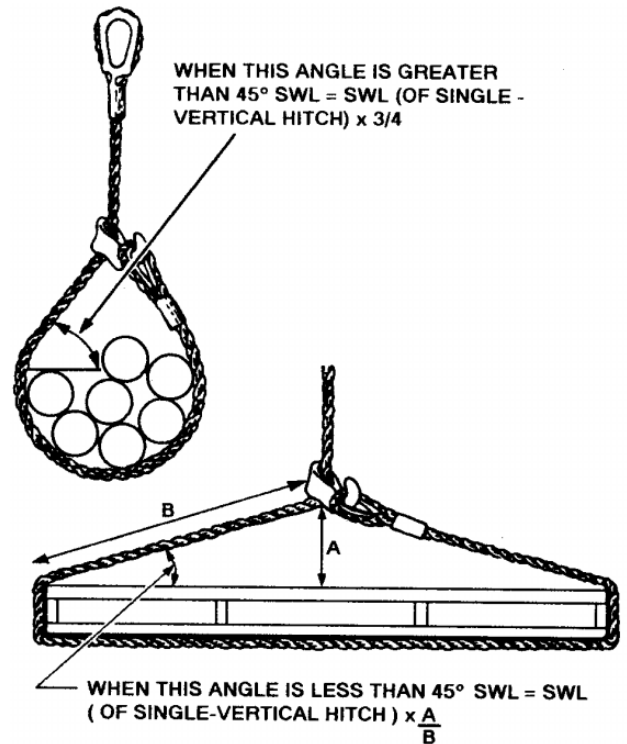

Figure 3-26.—Determination of single-choker hitch sling capacity.

Sling angles of less than 45 degrees are not recommended; however, if they are used, the formula is $SWL = SWL$ (of single-vertical hitch) $\times A/B$.

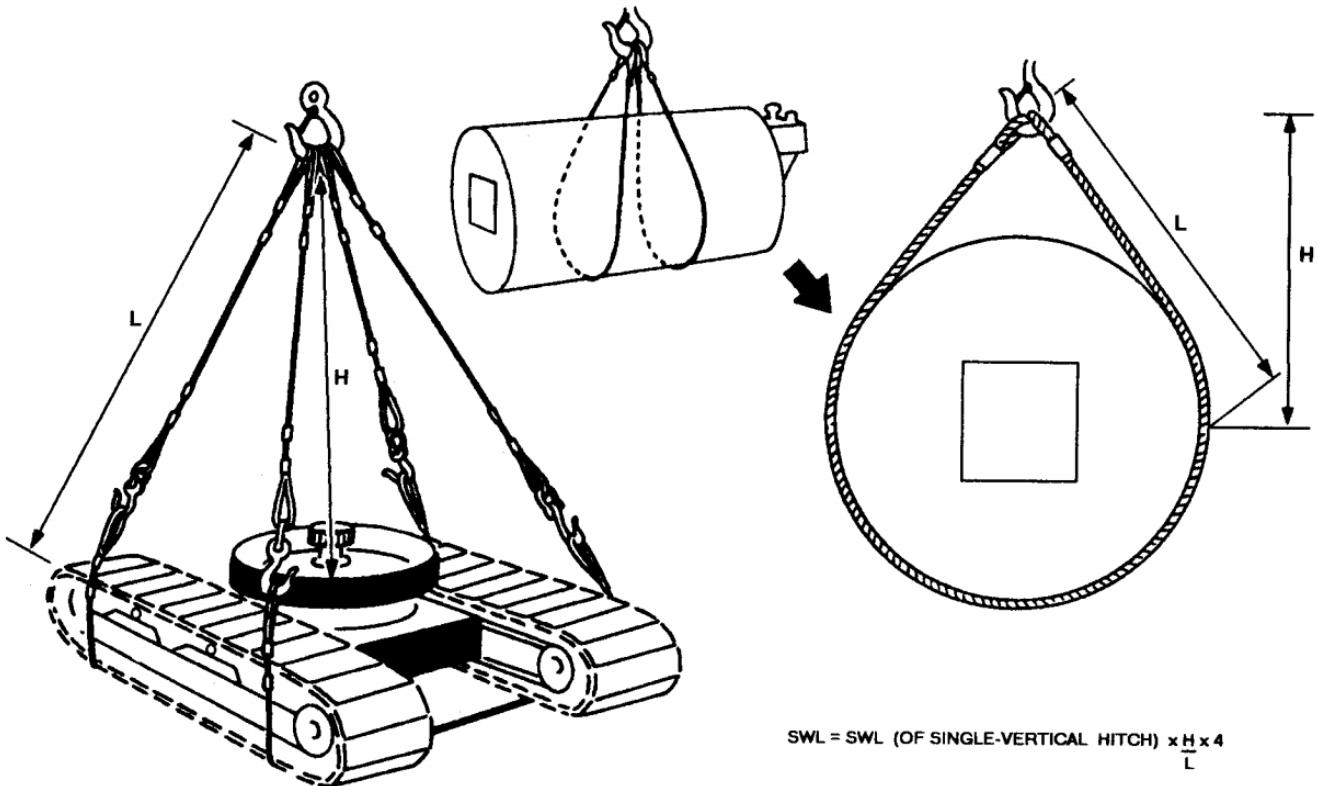

Figure 3-25.—Determination of double-basket hitch sling capacity.

Double-Choker Hitch (fig. 3-27): For sling angle of 45 degrees or more, SWL = SWL (of single-vertical hitch) x 3 divided by 4 x H divided by L x 2.

Sling angles of less than 45 degrees, SWL = SWL (of single-vertical hitch) x A divided by B x H divided by L x 2.

Eye Splices

Most of the attachments used with wire rope are designed to provide an eye on the end of the wire rope by which the maximum strength of the wire rope can be obtained when the wire rope is connected to a load. With the exception of some slings, all spiced eyes should incorporate rope thimbles to maintain rope strength and reduce wear. If a thimble is not used, the efficiency of the connection can be reduced by as much as 10 percent because the rope flattens under the load (fig. 3-28).

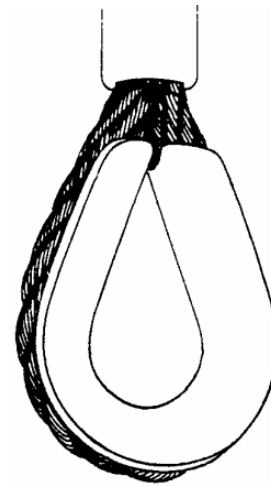

Figure 3-28.-Wire rope thimble.

Every wire rope manufacturer attaches a different name to its particular type of eye splice; however, there are usually variations in the three basic groups:

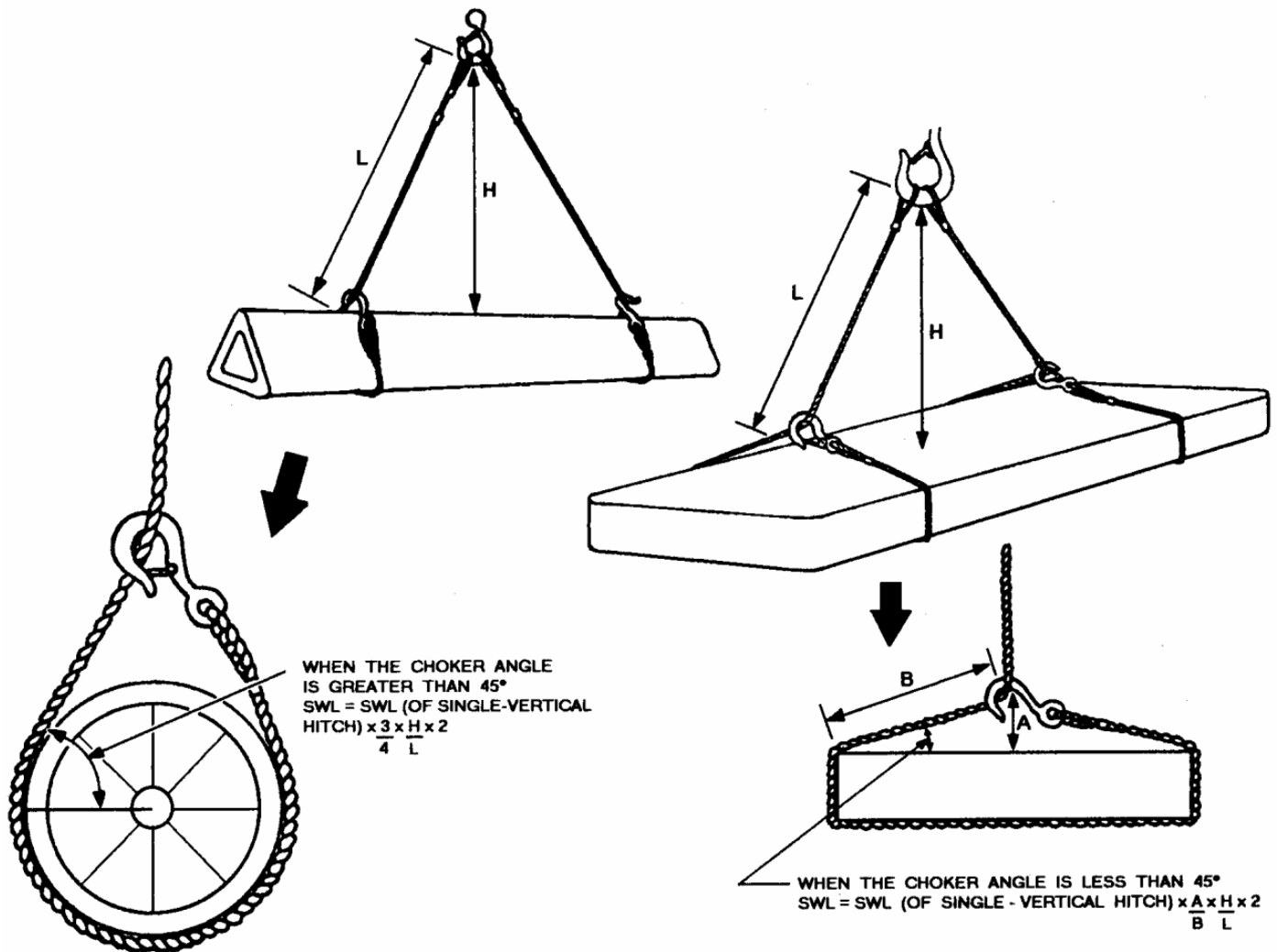

Figure 3-27.—Determination of double-choker hitch sling capacity.

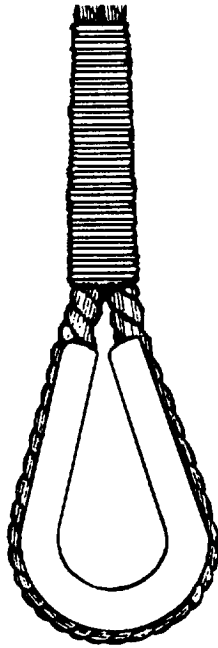

Figure 3-29.-Flemish eye and serving.

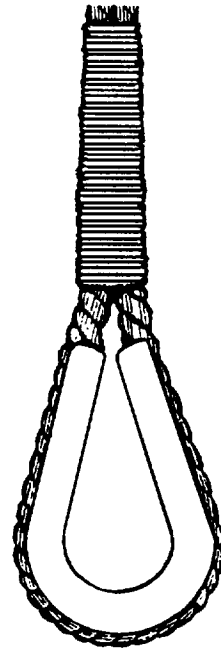

Figure 3-31.-Tucked eye and serving.

Group 1: Flemish eye and serving (fig. 3-29)
 Flemish eye and pressed metal sleeve
 (fig. 3-30)

Group 2: Tucked eye and serving (fig. 3-31)
 Tucked eye and pressed metal sleeve
 (fig. 3-32)

Group 3: Fold back eye and pressed metal sleeve
 (fig. 3-33)

The splices in group one are the best and most secure. The flemish eye with the pressed metal sleeve is recommended for all rigging and hoisting use. When properly fabricated, it develops almost 100 percent of the catalogue breaking strength. The strand ends of the spliced rope are secured against the live portion of the rope by means of a steel or aluminum sleeve set in place under pressure.

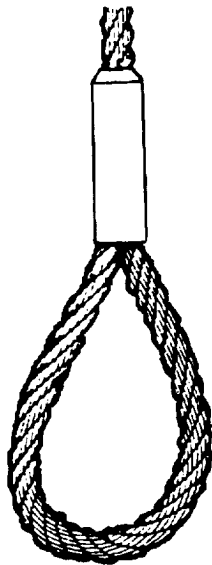

Figure 3-30.-Flemish eye and pressed metal sleeve.

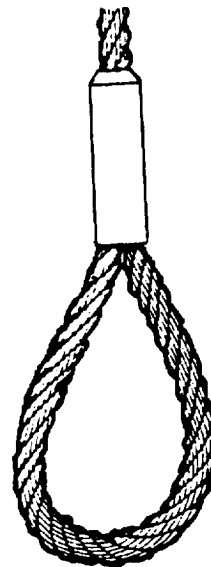

Figure 3-32.—Tucked eye and pressed metal sleeve.



Figure 3-33.—Fold back eye and pressed metal sleeve.

The tucked eye with the pressed metal sleeve is almost 100 percent efficient; however, the tucked eye and serving in group 2 can develop only 70 percent of the strength of the rope and tend to come free as the rope unwinds. As the rope untwists, the tucks in the eye begin to pop free. All eye splices in group 2 should have a least five tucks, and the complete splice should be carefully and tightly wrapped with a wire serving to cover the whole splice.

The fold back eyes and pressed metal sleeves in group 3 are fabricated by bending the rope to the eye dimension required and securing the free or dead end of the rope against the live portion of the rope by means of a steel or aluminum sleeve set in place under pressure. Improper swaging or split sleeves used with fold back eye splices (fig. 3-34) can result in complete failure without warning. It is highly recommended that these eye splices never be used for overhead hoisting operations.

An alternate method of forming a soft eye in the end of a wire rope without the use of permanent splicing is fabricating a flemish eye splice (Molley Hogan). The eye is simple to form, requiring a minimum amount of tools, and does not require use of a splicing vise. The flemish eye develops 90 percent of the breaking strength of the wire rope.

To form a flemish eye (fig. 3-35), unlay the rope strands 3 to 4 inches longer than twice the

circumference of the eye size desired. The wire rope core can be cut out or laid in one section of the wire. A simple overhand knot is made, letting the strands lay together and adjusting the eye to the desired size. Bend sections of the strands through the eye so that the strands re-lay into position to form the rope. Continue until the eye is completed. Secure the bitter ends of the strand to the rope with lashing, seizing, or a wire clip to prevent unlaying of the rope. Before the sling can be put into use, it must be proof-tested and tagged.

Proof-Testing

All field-fabricated slings terminated by mechanical splices, sockets, and pressed and swaged

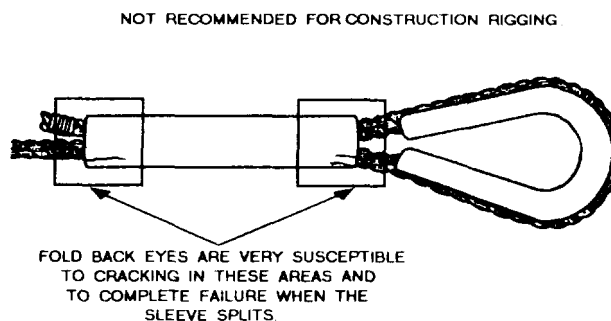

Figure 3-34.—Fold back sling failure.

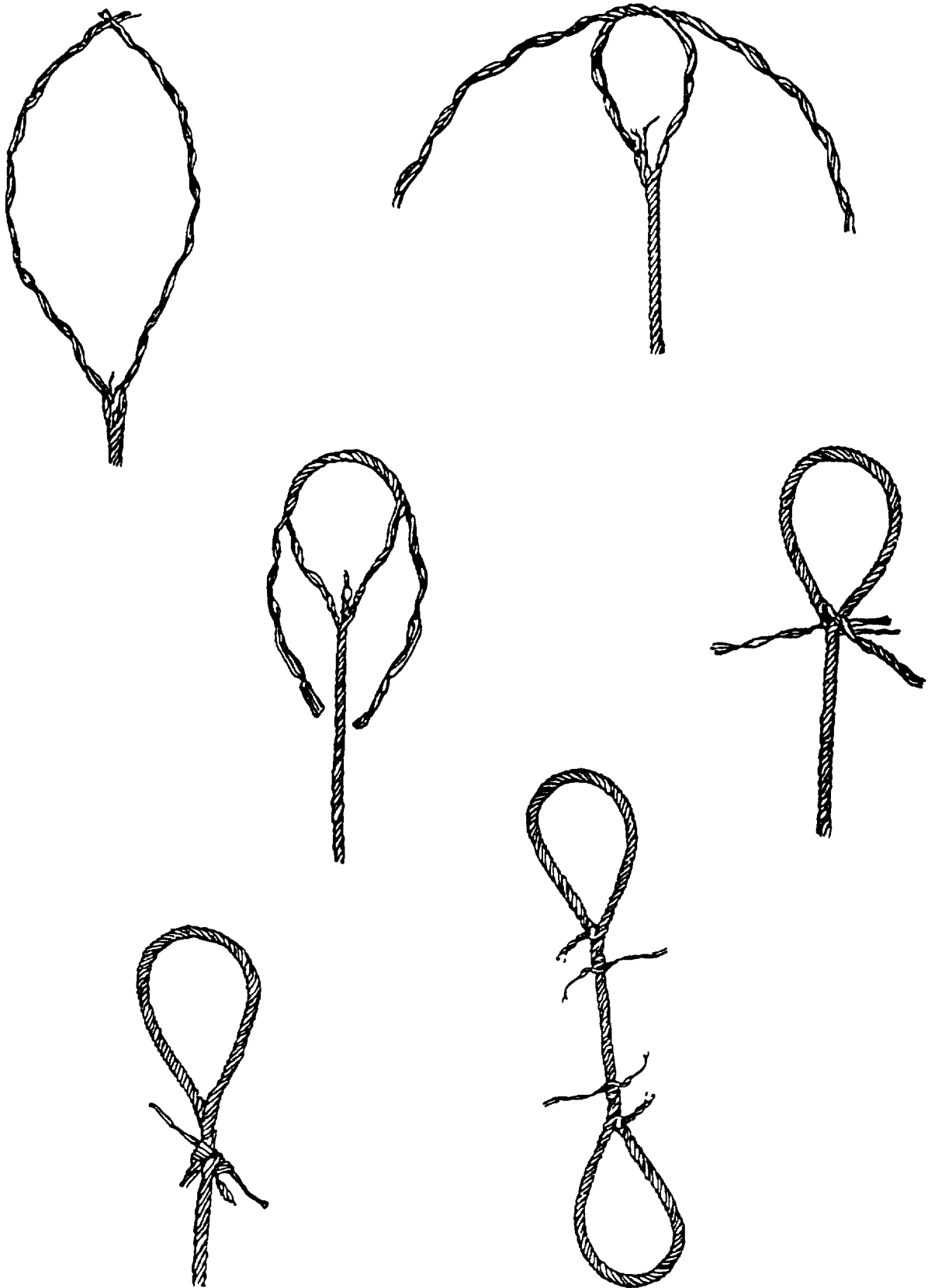

Figure 3-35.-Flemish eye development.

terminals must be proof-loaded before placing the sling in initial service.

The COMSECOND/COMTHIRDNCBINST 11200.11 series has rated capacity charts enclosed for numerous wire rope classifications. You must know the diameter, rope construction, type of core, grade, and splice on the wire rope sling before referring to the charts. The charts will give you the vertical-rated capacity for the sling. The test weight for single-leg bridle slings and endless slings is the vertical-rated capacity (V.R.C.) multiplied by two or (V.R.C. x 2 = sling test weight).

The test load for multiple-leg bridle slings must be applied to the individual legs and must be two times the vertical-rated capacity of a single-leg sling of the same size, grade, and wire rope construction. When slings and rigging are broken out of the TOA for field use, they must be proof-tested and tagged before being returned to CTR for storage.

Records

The crane crew supervisor must establish and maintain a card file system containing a record of each sling in the unit's inventory. Proof Test/Inspection Sheets (fig. 3-36) are used to document tests made on all items of weight-lifting slings, spreader bars, hooks, shackles, and so forth. These records are permanent and contain the following entries at a minimum:

1. Sling identification number (unit location and two-digit number with Alfa designation for each wire rope component)
2. Sling length
3. Cable body diameter (inches) and specifications
4. Type of splice
5. Rated capacity
6. Proof test weight
7. Date of proof test
8. Signature of proof test director

All the slings must have a permanently affixed, near the sling eye, durable identification tag containing the following information:

1. Rated capacity (in tons) (vert. SWL)
2. Rated capacity (in tons) (45-degree SWL)

3. Identification number

Spreader bars, shackles, and hooks must have the rated capacities and SWL permanently stenciled or stamped on them. OSHA identification tags can be acquired at no cost from COMTHIRDNCB DET, Port Hueneme, California, or COMSECONDNCB DET, Gulfport, Mississippi. Metal dog tags are authorized providing the required information is stamped onto the tags.

Storage

Wire rope slings and associated hardware must be stored either in coils or on reels, hung in the rigging loft, or laid on racks indoors to protect them from corrosive weather and other types of damage, such as kinking or being backed over. Slings are not to be left on the crane at the end of the workday.

Sling and Rigging Gear Kits

The NCF has slings and rigging gear in the Battalion Table of Allowance to support the rigging operations and the lifting of CESE. The kits 80104, 84003, and 84004 must remain in the custody of the supply officer in the central toolroom (CTR). The designated embarkation staff and the crane test director monitor the condition of the rigging gear. During the BEEP, the two crane crew supervisors normally have the responsibility to inventory the contents of the kits. The rigging kits must be stored undercover.

Wire Rope Sling Inspection

All wire rope slings must be visually inspected for obvious unsafe conditions before each use. A determination to remove slings from service requires experience and good judgment, especially when evaluating the remaining strength in a sling after allowing for normal wear. The safety of the sling depends primarily upon the remaining strength. Wire rope slings must be immediately removed from service if any of the following conditions are present:

1. Six randomly distributed broken wires in one rope lay or three broken wires in one strand in one lay
2. Wear or scraping on one third of the original diameter of outside individual wires

WIRE ROPE SLING PROOF TEST/INSPECTION RECORD

DATE

SLING I.D. NO.

Specification: _____

Length: _____

Cable body diameter: _____

Type splice: _____

Rated capacity (lbs): _____

* Proof test weight (lbs): _____

* Date of proof test: _____ Proof test director sig: _____

Date of inspection: _____ Crane Supv inspector sig: _____

Date of inspection: _____ Crane Supv inspector sig: _____

Date of inspection: _____ Crane Supv inspector sig: _____

REMARKS:

* Applies only to field fabricated slings.

WIRE ROPE SLING PROOF TEST/INSPECTION RECORD

Card ____ of ____

DATE

SLING I.D. NO.

Specification: _____

Length: _____

Cable body diameter: _____

Type splice: _____

Rated capacity (lbs): _____

* Proof test weight (lbs): _____

* Date of proof test: _____ Proof test director sig: _____

Date of inspection: _____ Crane Supv inspector sig: _____

Date of inspection: _____ Crane Supv inspector sig: _____

Date of inspection: _____ Crane Supv inspector sig: _____

REMARKS:

* Applies only to field fabricated slings.

Figure 3-36.-Proof Test/Inspection Sheet.

3. Kinking, crushing, bird caging, or any other damage resulting in distortion of the wire rope structure
4. Evidences of heat damage
5. End attachments that are cracked, deformed or worn
6. Hooks that have an obviously abnormal (usually 15 percent from the original specification) throat opening, measured at the narrowest point or twisted more than 10 degrees from the plane of the unbent hook
7. Corrosion of the wire rope sling or end attachments

To avoid confusion and to eliminate doubt, you must not downgrade slings to a lower rated capacity. A sling must be removed from service if it cannot safely lift the load capacity in which it is rated. Slings and hooks removed from service must be destroyed by cutting before disposal. This ensures inadvertent use by another unit. When a leg on a multiple-leg bridle sling is unsafe, you only have to destroy the damaged or unsafe leg(s). Units that have the capability may fabricate replacement legs in the field, provided the wire rope replacement is in compliance with specifications. The NCF has a hydraulic swaging and splicing kit in the Battalion Table of Allowance. The kit, 80092, contains the tools and equipment necessary to fabricate 3/8- through 5/8-inch sizes of wire rope slings. Before use, all fabricated slings must be proof-tested, as outlined in the COMSECOND/COMTHIRDNCBINST 11200.11 series.

Spreader bars, shackles, hooks, and so forth, must also be visually inspected before each use for obvious damage or deformation.

A visual inspection of all active slings and rigging gear must be conducted by the crane crew supervisor every 60 days. The inspections are noted on the Proof Testing/Inspection Record Cards. Any deterioration that could result in an appreciable loss of the original strength of a sling or component justifies it being removed immediately from service. After passing inspection, a proof test must be conducted before returning a sling to service.

Wire Rope Maintenance

Wire rope must be thoroughly cleaned at regular intervals. A wire brush can be used to remove most of the dirt and grit that may accumulate on the wire.

Rust should also be removed when the rope is cleaned. After cleaning, you should allow the wire rope to dry before it is lubricated.

The object of cleaning wire rope is to remove all foreign material and old lubricant from the valleys between the strands and the spaces and between the outer wires to permit the lubricant to penetrate into the rope.

Wire Rope Lubrication

Periodic lubrication of wire rope is essential to prolong the life of a rope. Lubricants generally do not last through the life of a rope; therefore, this requires that the lubricant be renewed. A good grade of new oil or grease (never use engine oil) can be used for this purpose. It should be free of acids and alkalis and should be light enough to penetrate between the wires and strands of the rope and applied as uniformly as possible throughout the length of the rope. COMSECOND/COMTHIRDNCBINST recommends the use of 70:30 ratio of new oil to diesel fuel for a wire rope lubricant. Wire rope should be cleaned and lubricated before storing.

Wire Rope Safe Operating Procedures

All personnel involved with the use of wire rope slings should be thoroughly instructed and trained to comply with the following practices:

1. Wire rope slings must not be used with loads that exceed the rated capacities outlined in enclosure (2) of the COMSECOND/COMTHIRDNCBINST 11200.11 series. Slings not included in the enclosure must be used only according to the manufacturer's recommendation.
2. Determine the weight of a load before attempting any lift.
3. Select a sling with sufficient capacity rating.
4. Examine all hardware, equipment, tackle, and slings before using them and destroy all defective components.
5. Use the proper hitch.
6. Guide loads with a tag line when practical.
7. When using multiple-leg slings, select the longest sling practical to reduce the stress on the individual sling legs.
8. Attach the sling securely to the load.

9. Pad or protect any sharp corners or edges the sling may come in contact with to prevent chaffing.

10. Slings are to be kept free of kinks, loops, or twists.

11. Keep hands and fingers from between the sling and the load.

12. Start the lift slowly to avoid shock loading slings.

13. Keep slings well lubricated to prevent corrosion.

14. Do not pull slings from under a load when the load is resting on the slings; block the load up to remove slings.

15. Do not shorten a sling by knotting or using wire rope clips.

16. Do not inspect wire rope slings by passing bare hands over the rope. Broken wires, if present, may cause serious injuries. When practical, leather palm gloves should be worn when working with wire rope slings.

CHAPTER 4

PROJECT SUPERVISOR

The mission of the Naval Mobile Construction Battalion (NMCB) includes operational readiness, construction, defense, and disaster preparedness operations. To achieve these assigned missions, the NMCB is organizationally structured for the dual purpose of construction and military support operations.

The commanding officer (CO) of the NMCB has direct responsibility for the timely preparedness and successful completion of all construction projects and disaster recovery operations assigned to the NMCB by higher authority. The operations officer (S-3) is responsible to the CO for management of the construction and disaster preparedness programs. Additionally, the operations officer is granted direct supervisory authority over the utilization of the battalion's construction resources: personnel, equipment, and materials. The element in the overall NMCB organization by which the battalion's mission is accomplished is the company structure (fig. 4-1).

The NMCB is composed of two categories of companies: construction companies and line

companies. Construction companies are designated as Alfa, Bravo, Charlie, and Delta. These companies have the capabilities needed for direct mission accomplishment. Headquarters company is the line company and serves as the military and administration organization for the NMCB.

Within the battalion, Alfa company has the primary responsibility for the operation and maintenance of all assigned automotive, construction, and weight-handling equipment. Under the construction concept of *prime contractor/lead company*, Alfa company performs as a prime or subcontractor, sometimes both, for assigned construction projects. The prime contractor is responsible for the safety, quality, and timeliness of the construction effort and directs subcontract support accordingly. The subcontractor is responsible for providing resources in sufficient quantity and quality to accomplish a portion of a construction project according to schedules.

The Alfa company commander (A-6) is directly responsible to the operations officer (S-3) for Alfa company assigned projects. The Alfa company operation chief (A-3) is responsible to the company commander for all prime and subproject support and normally assigns a projects chief (A-32) to support the management of the construction projects. The company commander, company operation chief, and projects chief, and usually, the company chief jointly review the preliminary construction tasking for an assigned prime project or projects. They then select the project supervisor(s) who is/are given the responsibility to carry out the project tasking. The company selected project supervisor is appointed by the operations officer for the assigned construction project.

PROJECT SUPERVISOR RESPONSIBILITIES

In some commands, the project supervisor is referred to as the "crew leader." In this chapter, the term *project supervisor* refers to the individual assigned as the person in charge of a construction project. This chapter presents the basic information you are required to know in order to perform the duties and carry out your responsibilities when assigned as a project supervisor.

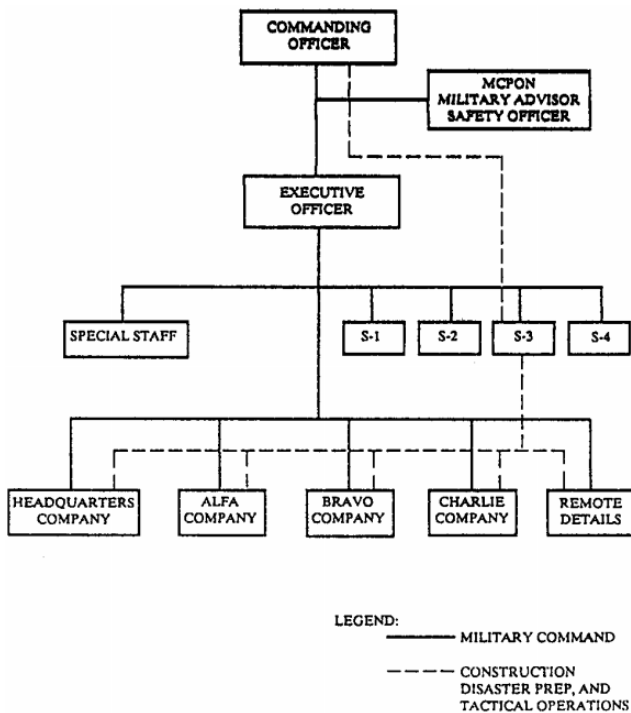

Figure 4-1.—Model of an NMCB organization.

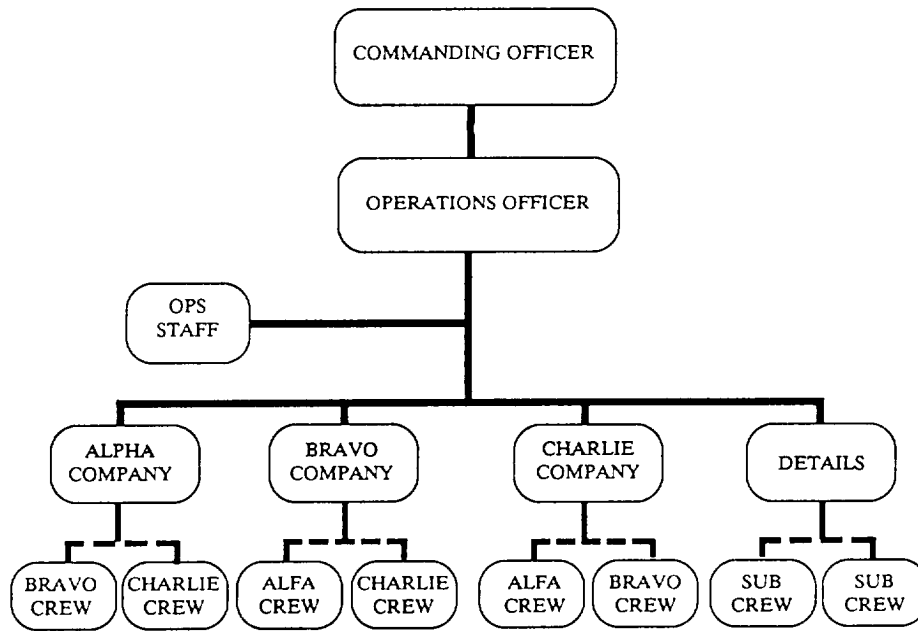

Figure 4-2.-Prime contractor/lead company organization.

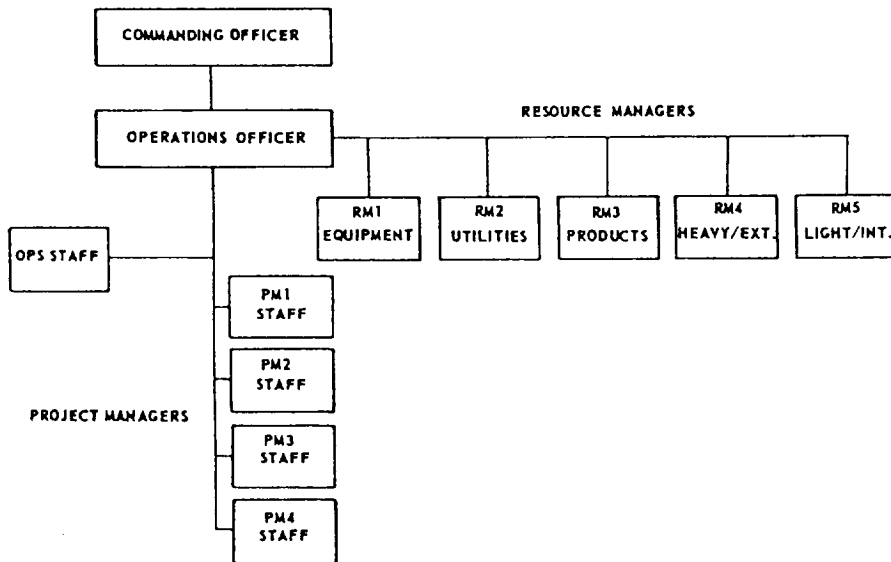

Figure 4-3.-Project manager/resource manager organization.

CONCEPTS OF CONSTRUCTION

Construction operations are conducted under several different organizational concepts. Depending upon the particular objectives of each deployment, the CO and the S-3 officer determine the organizational concept that is most effective for the execution of the assigned objectives while maintaining readiness integrity. Although there are many variations that can be used in a construction organization, there are three

concepts that are most often used by the Naval Construction Force (NCF). These concepts are as follows:

- Prime contractor/lead company
- Project manager/resource manager
- Self-sufficient unit/detail

Most construction operations in the NCF are conducted under the *prime contractor/lead company*

concept (fig. 4-2). In this organization the company commanders are directly responsible to the operations officer for the timely and successful completion of construction projects assigned to them by the operations officer. The *project manager/resource manager concept* (fig. 4-3) requires construction projects be assigned directly to a project manager who is normally outside the company organization. The project managers are then responsible directly to the operations officer for the completion of the project to include the following: planning, scheduling of resources, direct project supervision, and reporting. The entire battalion labor force is reorganized into resource "pods," either by rate or by type of work to be accomplished (such as block crews, concrete crews, finish crews, and wiring crews). A resource manager is placed in charge of each pool. The resource manager has the responsibility to utilize their assigned personnel, tools, and equipment effectively, without regard to project assignment, and provide the administration support required by the military organization. The *self-sufficient unit concept* (fig. 4-4) is used when the battalion establishes details to accomplish specific tasks at locations remote from the main body site. These details are organized and staffed with all resources required to accomplish the specific assigned mission; therefore, the self-sufficient unit. The three concepts are outlined in the *Naval Construction Force Manual*, NAVFAC P-315.

No matter what construction concept is used, the prime contractor, project manager, or the officer in charge (OIC) of the self-sufficient unit is directly responsible to the operations officer.

DEPLOYMENT PLANNING

The key to a successful deployment is well-developed plans. This planning phase begins 2 months before the end of the previous deployment and continues through the end of home port. More details of how construction projects are planned and laid out are covered in the *Naval Construction Force/Seabee Petty Officer First Class*, NAVEDTRA 10601, and the *Naval Construction Force/Seabee Chief Petty Officer*, NAVEDTRA 10600. The following is a general overview of how deployment tasking is planned. The planning phase is subdivided into seven distinct steps: *initial planning step*, *follow-on planning step*, *detailed planning step*, *predeployment trip step*, *ready-to-deploy evaluation step*, *advance party phase (final evaluation step)*, and *the main body arrival step*.

The *initial planning step* is the period in which the battalion receives its preliminary tasking and begins

DETAIL ORGANIZATION

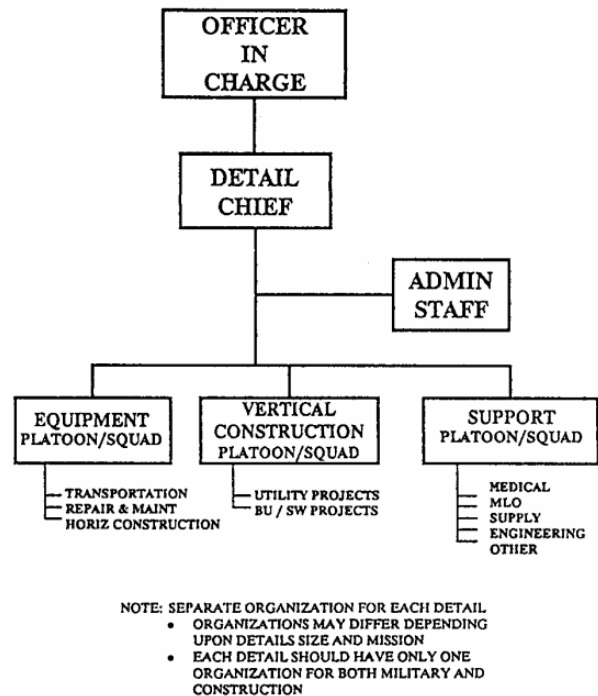

Figure 4-4.-Self-sufficient unit organization.

monitoring the efforts, plans, tasking, and work load of the on-site battalion at the next deployment site. The battalion also organizes a planning group that consist of personnel who are knowledgeable individuals in their particular rating. This group monitors the planning and estimating of the construction projects and performs as the quality control (QC) team during the deployment.

The *follow-on planning step* is the preliminary evaluation involving the in-depth study of all information received to date and the monitoring of the on-site battalions efforts. Part of the in-depth study is to evaluate any additional training needs for battalion personnel and to review and develop an overall method of execution for any particular project. After the preliminary evaluation is completed, the appropriate number of personnel for each detail, company, and staff elements are assigned. his evaluation should yield a significant number of questions which are normally resolved by message traffic, direct contact, or during the predeployment trip.

When the *detailed planning step* is reached, the battalion is ready to commence the project planning function. At this time, the companies and details become the primary planning units within the battalion. Also, this is when the project supervisor becomes involved with the planning and it is during this phase that the

project package is developed. Project packages are covered in the *NCF Seabee Petty Officer First Class*, NAVEDTRA 10601.

The quality control (QC) element assists the companies and details with the planning effort and coordinates the detailed analysis of project requirements. The analysis includes a distribution of resources required during various time frames to accomplish the battalion mission and also the monitoring of the on-site battalion's efforts and projecting the point at which each project should be turned over. This information, coupled with modifications to existing networks and new networks, is coordinated into a schedule. This schedule is based on the best information available and is subject to change as new information is received or as priorities change.

In conjunction with the detailed analysis and scheduling effort, each company reviews the bill of materials (BM) provided for a project and determines if it is complete. Each company also checks what tools and materials on the BM are required for each of the network activities. An estimate of all tools, equipment, personnel, time, material resources, quality control, safety plans, and special training requirements is developed during this step. This schedule is reviewed by the battalion staff and compared with the actual resources available to determine and resolve any excesses and deficiencies. After this step is completed, a preliminary overall battalion deployment plan should exist that indicates all projected evolutions of the battalion during the upcoming deployment and the schedule to accomplish them.

The *predeployment trip step* is a critical aspect in evaluating the project planning efforts of the battalion. This trip normally includes a visit to the main body and all current and anticipated detail sites.

The *ready-to-deploy evaluation step* is a readiness-to-deploy inspection (RDI) conducted by the regimental operations staff in three phases during the home-port period. The first phase inspection covers the battalion organizational and training plans; the second phase inspection covers the construction project plans; and the third phase covers the execution plans. These inspections are necessary to ensure that the battalion is well prepared for the upcoming deployment.

The *advance party phase* is the final evaluation step. During this phase, the advance party deploys to the main body site and to the various detail sites. Also, the monitoring efforts and planning accomplished by the

battalion up to this time are finalized to ensure proper employment of personnel.

The *main body arrival step* indicates the end of the primary planning cycle and commencement of the execution phase of the work; however, planning efforts of the battalion do not stop at this point, but assume a different role in the battalion's operations.

EARTHWORK COMPUTATIONS

Companies that are assigned as a prime contractor for a construction project are responsible for the full planning and estimating (P&E) of the project; however, areas of construction not relating to their specific skills normally require assistance from companies assigned as subcontractor for the planning and estimating of their area of expertise.

Normally, Alfa company is assigned to what is known as *horizontal construction*. The scope of the project is usually the primary factor in determining if Alfa company is assigned as the prime or subcontractor. As the project supervisor, you must be thoroughly knowledgeable of and stay on top of all P&E evolutions concerning your project. P&E estimates are used as a basis for purchasing materials and for determining equipment and manpower requirements. These estimates are also used in scheduling progress, which provides the basis for scheduling material deliveries, equipment, and manpower. You should review the project specifications and construction drawings and check all quantity estimates for accuracy. Mistakes made in P&E can be detrimental to the successful completion of the construction project.

Earthwork computations are calculations of earthwork volumes or quantities used to determine the following: final grades, balance cut and fill requirements, and PLANNING the most economical movement of material. Earthwork computations are a critical element in the planning of any project and the importance of these calculations cannot be overemphasized.

Volume Changes

Most earth moving is computed in cubic yards; however, on some deployment sites, the metric system is used. A cubic yard is a cube 3 feet long, 3 feet wide, and 3 feet high. Many dimensions in field measurements and contract plans are in feet; therefore, when they are multiplied together to obtain bulk (length x width x depth), the results

Table 4-1.-Volume Changes

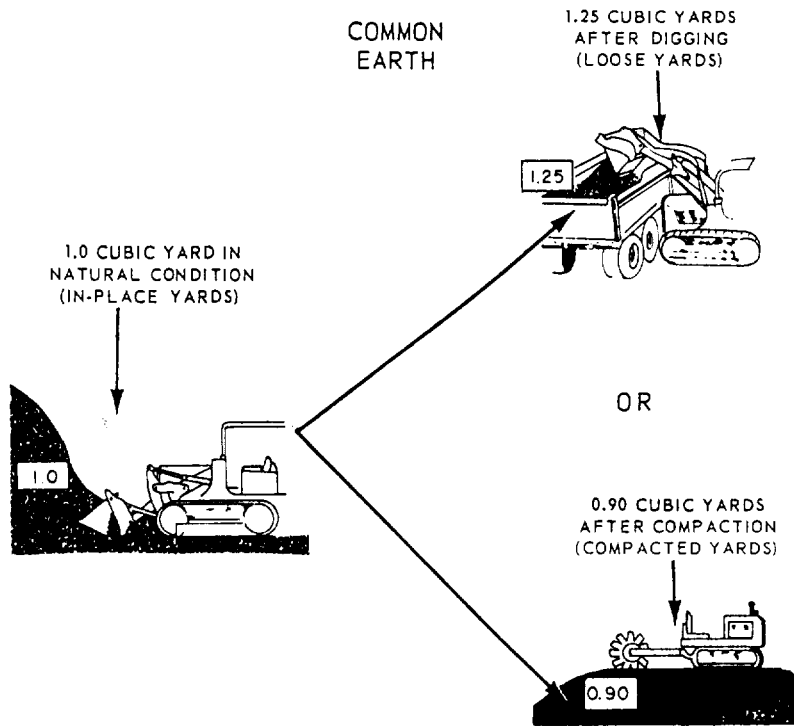

SOIL TYPE	PRESENT SOIL CONDITION	CONVERTED TO:		
		INPLACE	LOOSE	COMPACTED
SAND	INPLACE	1.00	1.11	0.95
	LOOSE	0.90	1.00	0.86
	COMPACTED	1.05	1.17	1.00
COMMON EARTH	INPLACE	1.00	1.25	0.90
	LOOSE	0.80	1.00	0.72
	COMPACTED	1.11	1.39	1.00
CLAY	INPLACE	1.00	1.43	0.90
	LOOSE	0.70	1.00	0.63
	COMPACTED	1.11	1.59	1.00
ROCK	INPLACE	1.00	1.30 - 2.00	1.25 - 1.50
	LOOSE	0.50 - 0.77	1.00	0.75 - 0.96
	COMPACTED	0.67 - 0.80	1.04 - 1.33	1.00

obtained are in cubic feet. To convert cubic feet into cubic yards, divide the cubic feet by 27 (there are 27 cubic feet in 1 cubic yard). Another method is to divide each original linear measurement by 3 to convert the number of feet into yards; then multiply the values together to cubic yards. Be aware, however, that this method may lead to working in fractions, decimals, and mixed numbers.

Cubic yards of material are either *inplace*, *loose*, or *compacted*. Material excavated in its natural state

increases in volume, commonly known as *swell*. Undisturbed material is measured as *inplace cubic yards*, material loosened by handling is measured in *loose cubic yards*, and the volume of compacted material is measured as *compacted cubic yards*. You must remember when calculating estimates from prints, cuts are estimated as *inplace cubic yards*, and fills are estimated as *compacted cubic yards*. To calculate the correct amount of material to be handled, you can convert the present soil conditions using table 4-1.

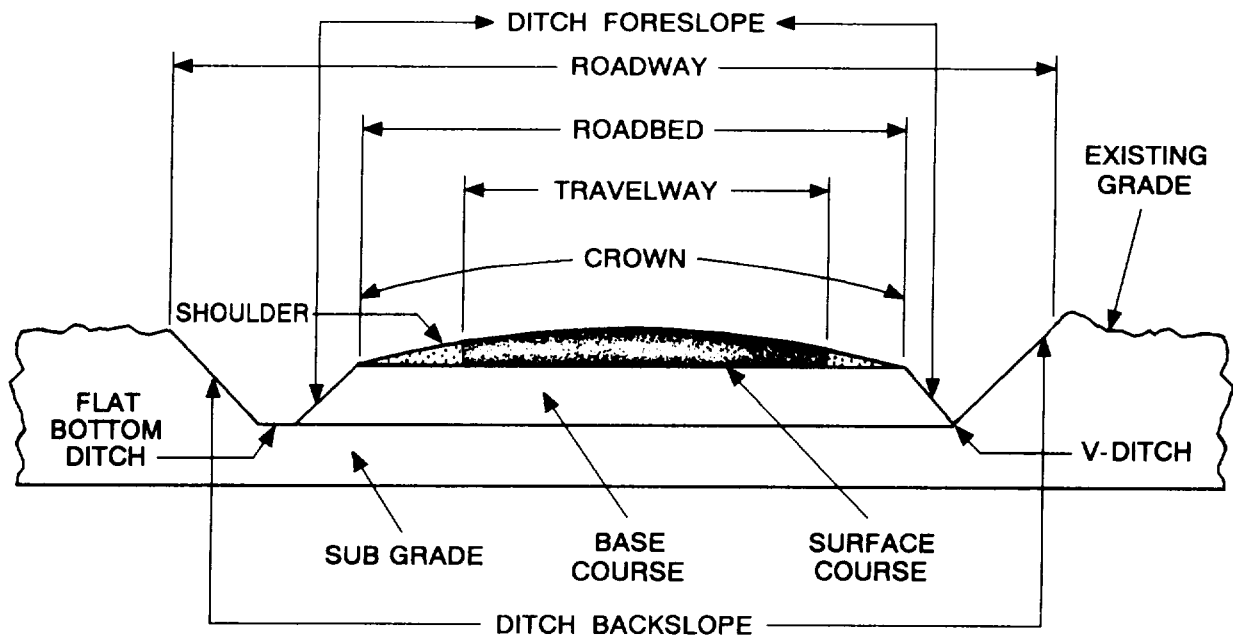
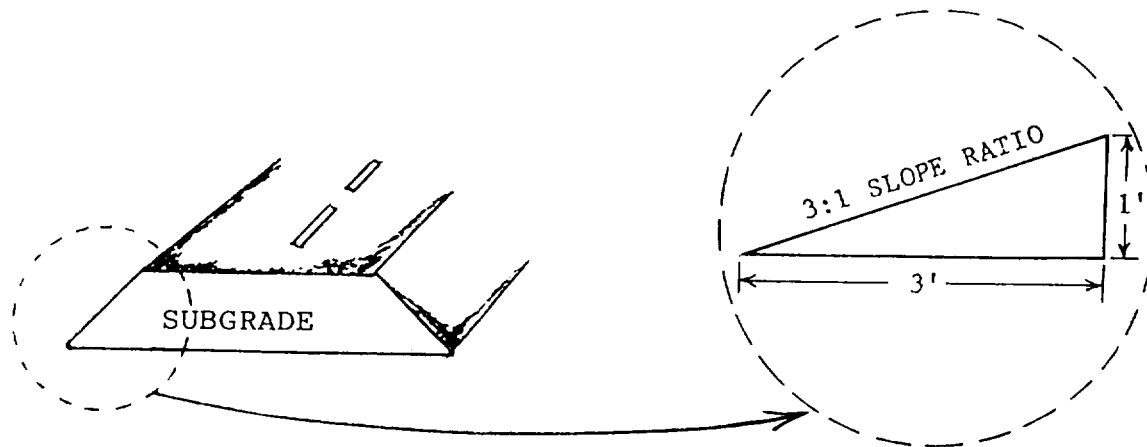
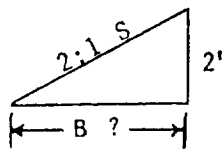

Figure 4-5. Road terminology.



3:1 (3 to 1) slope = 3' of horizontal distance for every one(1) foot of rise.



$$\text{SLOPE (2:1) X HEIGHT (2')} = 4' \text{ BASE}$$

$$S \times H = B$$

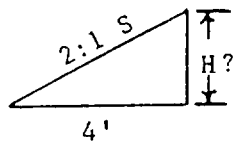

$$\text{BASE (4')} \div \text{SLOPE (2:1)} = 2' \text{ HEIGHT}$$

$$B \div S = H$$

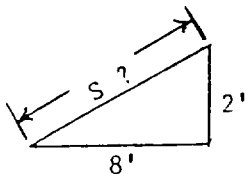

$$\text{BASE (8')} \div \text{HEIGHT (2')} = 4 \text{ (4 to 1) 4:1 SLOPE}$$

$$B \div H = S$$

Figure 4-6. Slope ratio.

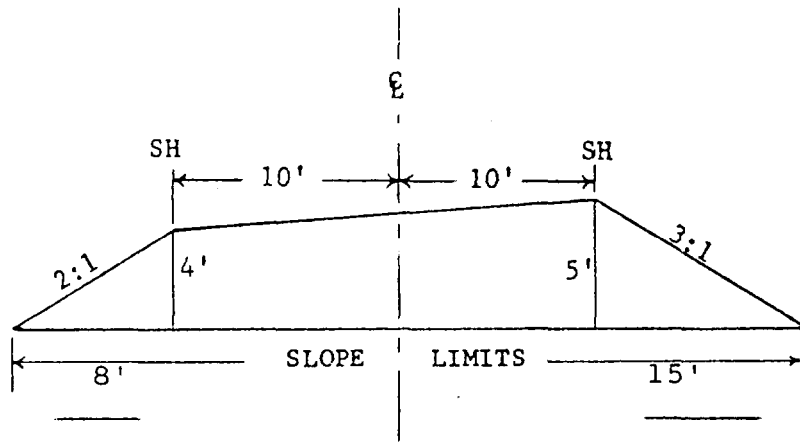

Figure 4-7.—Cross section.

Road Nomenclature

Part of the planning and estimating process is making sure your crew has the understanding of road terminology (fig. 4-5). Before any construction is performed on a project site, the elevation is known as *existing grade*. The driving surface of an existing road that is to be replaced is also known as the *existing grade*. The *subgrade* of a road is a prepared base for the placement of base course materials. The *base course* is a select layer of well-compacted soil that is placed in compacted lifts on top of the subgrade. This compaction can be accomplished by mechanical stabilization or chemical stabilization. The *surface course* and the *shoulders* complete the road. The surface course is usually concrete or asphalt and is part of the road that vehicles travel on. The shoulder of the road performs as a retainer on each side of the surface course and allows for an emergency parking area.

The *crown* of the road is an established slope from the center line of a roadbed to the outside of the shoulders and allows for excess water to drain from the surface into either a *V-type* or *flat bottom* ditch. The area that covers the entire width of the road project including the ditches is known as the *roadway*. The *roadbed* is the section that includes the surface course and both shoulders, and the *travelway* is the surface course that the vehicle travels on.

Slope Ratio

The two most common slopes used in road construction are the *backslope* and *foreslope*. The backslope extends from the top of the cut at the existing grade to the bottom of the ditch. The foreslope extends from the outside of the shoulder to the bottom of the

ditch. The amount of slope in a backslope or foreslope is the ratio of horizontal distance to vertical distance (fig. 4-6). This means that for every 1 foot of vertical (up or down) distance, the horizontal distance changes proportionally. The following are equations used to compute slope ratio:

1. If the base and the height are known factors, but not the slope, use:

$$\text{Base} \div \text{Height} = \text{Slope}$$

$$(B \div H = S)$$

2. If the slope ratio and height are known factors, but not the base, use:

$$\text{Slope} \times \text{Height} = \text{Base}$$

$$(S \times H = B)$$

3. If the base and the slope ratio are known factors, but not the height, use:

$$\text{Base} \div \text{Slope} = \text{Height}$$

$$(B \div S = H)$$

Cross Sections

A *cross-sectional view* (fig. 4-7) that is given for a road project is a cutaway end view of a proposed station between the left slope and the right slope. Typical cross sections are plotted at any intermediate place where there is a distance change in slope along the center line where the natural ground profile and grade line correspond. The cross section displays the slope limits, slope ratio, horizontal distance between centerline stakes and shoulder stakes. It also shows the vertical distance of the proposed cut or fill at the shoulder and centerline stakes.

TO COMPUTE THE AREA OF A CROSS SECTION, FIRST BREAK IT DOWN INTO GEOMETRIC FIGURES (SQUARES, TRIANGLES, ETC.); THEN COMPUTE EACH AREA SEPARATELY AND TOTAL THE RESULTS.

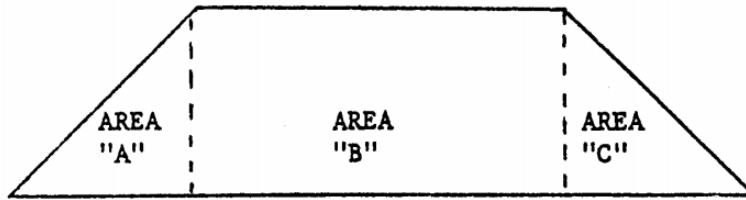

Figure 4-8.-Geometric sections of a cross section.

SQUARES and RECTANGLES may be computed for area by using the formula:

$$\text{AREA} = \text{BASE} \times \text{HEIGHT} \quad (A = B \times H)$$

EXAMPLE:

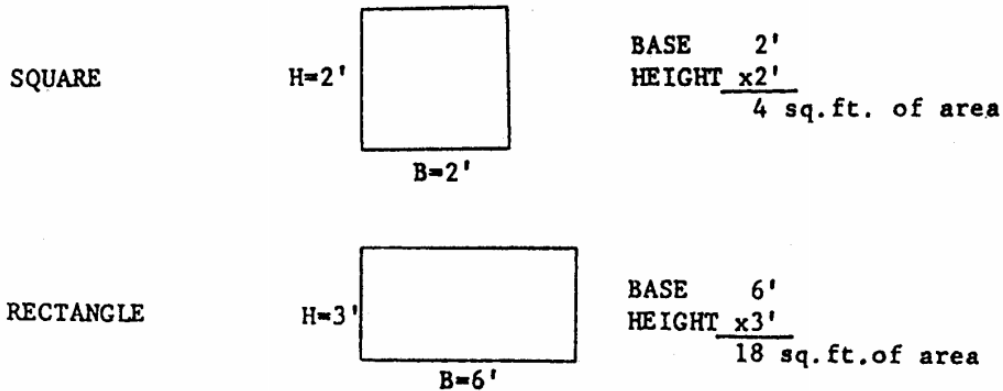

Figure 4-9.-Area of a square and rectangle.

To compute the area of across section, you must first break it down into geometric figures (squares, triangles, etc.). (See fig. 4-8.) Compute each area separately, then total the results to obtain the total square feet. To compute the square feet area of a SQUARE or RECTANGLE (fig. 4.9), use the following equation:

Area = Base \times Height or $(A = B \times H)$.
(See fig. 4-9.)

Since a RIGHT TRIANGLE is a square or rectangle cut in half diagonally, the same equation can be used to compute the area and the result divided by 2 (fig. 4-10). For example;

$$\text{Triangle area in square feet} = \frac{\text{Base} \times \text{Height}}{2}$$

or $B \times H \div 2 = \text{Triangle square feet}$

Another geometric figure you may encounter in a cross section is a TRAPEZOID (fig. 4-11). The equation to compute the area of a trapezoid is as follows:

$$\text{Trapezoid Area in square feet} = \left(\frac{H_1 + H_2}{2} \right) \times L$$

or $H_1 = \text{Height of one side}$

$+ H_2 = \text{Height of other side}$

$\text{Sum} \div 2 \times \text{Length} = \text{Trapezoid area in square feet.}$

The next step is to compute the total area in the cross section (fig. 4-12). This is accomplished by adding the results of each geometric figure in the cross section. This value is the total end area of the cross-sectional view.

To compute the amount of cubic yards between two cross sections, use the following equation:

THE FORMULA FOR COMPUTING THE AREA OF A TRIANGLE IS AS FOLLOWS:

$$\text{AREA} = \frac{\text{BASE} \times \text{HEIGHT}}{2} \quad \text{or } B \times H \div 2$$

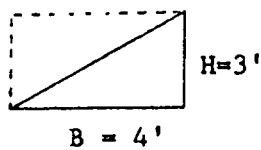

$$\begin{array}{r} \text{BASE} \quad 4' \\ \text{HEIGHT} \times 3' \\ \hline 2) 12 = 6 \text{ sq. ft.} \end{array}$$

Figure 4-10.-Area of a triangle.

THE FORMULA FOR COMPUTING THE AREA OF A TRAPEZOID IS AS FOLLOWS:

$$\text{AREA} = \frac{H_1 + H_2}{2} \times L$$

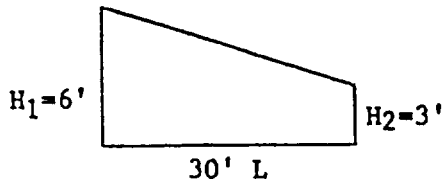

$$\begin{array}{r} H^1 = 6' \\ H^2 = +3' \\ \hline 2) 9 = 4.5 \times 30' = 135.0 \text{ sq. ft.} \end{array}$$

Figure 4-11.-Area of trapezoid.

THE FORMULA FOR COMPUTING CUBIC YARDS IS AS FOLLOWS:

$$(A_1 + A_2) 1.85 \times \text{DISTANCE} = \text{CUBIC YARDS}$$

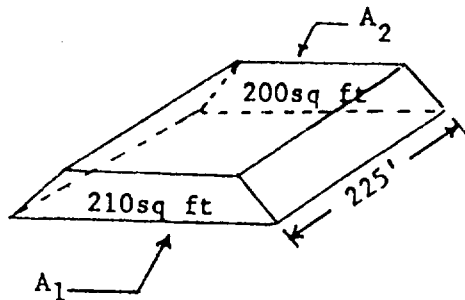

$$\begin{array}{r} A_1 = 210 \quad \text{sq ft} \\ A_2 = +200 \quad \text{sq ft} \\ \hline 410 \\ \times 1.85 \quad \text{FACTOR} \\ \hline 2050 \\ 3280 \\ 410 \\ \hline 758.50 \\ \times 2.25 \quad \text{DISTANCE} \\ \hline 379250 \\ 151700 \\ \hline 151700 \\ 1706.6250 \\ \hline 1706.63 \quad \text{CUBIC YARDS} \end{array}$$

Figure 4-12.-Computing cubic yards of cross sections.

CONSTRUCTION ACTIVITY SUMMARY SHEET

PROJECT TITLE: _____

B.M. CODE: _____ PREPARED BY: _____ CHECKED BY: _____

START SCHEDULED: _____ FINISH SCHEDULED: _____
 ACTUAL: _____ ACTUAL: _____

ACT. NO. _____ ACT. CODE _____

ACT. TITLE: _____

DESCRIPTION OF WORK METHOD: _____

DURATION: ESTIMATED _____ MANDAYS: ESTIMATED _____ WORKWEEK: _____
 ACTUAL _____ ACTUAL _____

PRODUCTION EFFICIENCY FACTOR: _____ RESULTING DELAY FACTOR: _____

LABOR RESOURCES:

NO.	DESCRIPTION	QTY.		NO.	DESCRIPTION	QTY.

EQUIPMENT RESOURCES:

NO.	DESCRIPTION	QTY.		NO.	DESCRIPTION	QTY.

MATERIAL RESOURCES:

L/I	DESCRIPTION	U/I	QTY.		NO.	DESCRIPTION	U/I	QTY.

ASSUMPTIONS: _____

Figure 4-13.-CAS sheet.

$$(A_1 + A_2) \times 1.85 \times \text{Distance} = \text{Cubic yards}$$

A₁ = Area of one end cross section

A₂ = Area of other end of cross section

1.85 = Constant factor

D = Distance between two end areas that must be changed to a decimal form; for example, 250 feet = 2.50, 125 feet = 1.25, 75 feet = .75, and so forth

To compute the equation take the area of one end section (cross section) plus the area of the other end and multiply the sum of the two areas by a constant factor of 1.85. This value should now be multiplied by the distance between the two end areas to determine the number of cubic yards. (See fig. 4-12.)

Earthwork equations to compute the volume of concrete are outlined in chapter 7. Other areas, such as equations to compute for prime and tack costs, single- and double-surface treatments, and asphalt volumes, are outlined in chapter 8.

EQUIPMENT ESTIMATES

Equipment estimates are used with production schedules to determine the construction equipment requirements and constraints for a construction project. One fact that must be remembered is that the speed of the equipment usually averages between 40 to 56 percent of the posted speed limit. The primary factors responsible for the variation in the percentage of the posted speed limit are as follows: road conditions, the

number of intersections, the amount of traffic, and hauling distances. Other factors considered are the types of material hauled (for example, damp sand or loam is much easier to handle than clay), safety (equipment limitations), operator experience, conditions of the equipment, work hours, and the local climate.

Equipment production must be determined so the amount and type of equipment may be selected. Equipment production rates are available in the *Seabee Planner's and Estimator's Handbook*, NAVFAC P-405. The handbook provides information on estimating construction work elements and material quantities, including equipment and manpower requirements. The production rate per day should be estimated for each piece of equipment. Consider the factors discussed above, information obtained from NAVFAC P-405, and your experience. The quantity of work divided by the production rate per day produces the number of days required to perform the project. Equipment required to support each construction activity is documented on the Construction Activity Summary Sheet (CAS sheet) (fig. 4-13), which is part of the project package. One of the purposes of the project package is to allow the project supervisor and the assigned P&E crew to perform a documented thorough analysis of their assigned project and to lay out an organized sequence plan of operation in order to complete the assigned tasking. Detailed information on project packages, project planning, project execution, and construction project supervision are outlined in the *Naval Mobile Construction Battalion Crew Leader's Handbook*.

CHAPTER 5

QUARRY SUPERVISOR

This chapter provides information on the selection and operations of pits and quarries. It describes basic principles of site selection, preparation, and methods and techniques of developing pits and quarries.

QUARRY SUPERVISOR RESPONSIBILITIES

Pit and quarry operations in the Naval Construction Force (NCF) are normally managed by Alfa company. The operations chief of Alfa company is usually responsible for the pit and quarry operations and normally assigns a quarry supervisor to direct the operations of the pit and quarry.

PITS AND QUARRIES

The operation of the pit and quarry is directly determined by the material requirements and tasking for construction projects and rock crushing operations. The size of the crew assigned to support the pit or quarry operations is dictated by the availability of the equipment and material required for a construction task.

Pits and quarries are classified according to the type of material they contain and the methods used to excavate and process the material (table 5-1).

Pits

Pits are excavations made at the earth's surface in unconsolidated materials, such as clay, sand, gravel, coral, and laterite. They are sites from which suitable construction materials are obtained in quantity, being removed or extracted from the surface without the use of blasting. Alluvial or stream-deposited gravel pits yield gravel that is usually clean and free of clay and humus and are therefore desirable for concrete and bituminous work. Bank or hill gravel pits yield a clayey gravel that is desirable for road or runway surfacing because of its binding qualities. Gravel is also used for base courses and fills. Soil (other than sand and gravel) selected for use in embankments, fills, and subgrades is obtained from borrow pits. Miscellaneous pits contain mixed tailings, slag, cinders, or the like, which are also used for road or runway surfacing and as aggregates.

Quarries

Quarries are sites where large, open excavations are made for the purpose of extracting or removing rock in its natural state by drilling, cutting, and blasting. In some cases, it may be possible to remove and break up rock by use of dozer rippers and bull pricks (jack hammer attachment). The primary types of rocks obtained from quarries are igneous and metamorphic, such as trap rock, granite, diorite, gneiss, quartzite, and certain shales. Military quarries are generally open-faced, which means the vertical surface of the rock is exposed. Since seldom used in its in-place state, quarry rock is processed with mobile equipment that crushes, screens, and washes.

SITE SELECTION

Before a pit or quarry is located, an investigation of the site must be performed to establish that suitable construction materials are available in adequate amounts and that the excavation can be worked efficiently with available equipment. Whenever possible, existing pits and quarries are used because (1) the quantity and quality of materials can easily be determined; (2) good haul and access roads are probably already built; (3) less effort can be spent on removal of overburden; and (4) facilities, such as ramps, hoppers, bins, power, and water, are generally available.

The chosen site should be as close as possible to the construction project and convenient to good routes of transportation. This allows more efficient hauling by decreasing the length of haul roads. Pit and quarry haulage is usually accomplished with equipment, such as dump trucks and scrapers.

Soil Formation

The formation of soil is a continuous process. Basically, the crust of the earth consists of rock that geologists classify into three groups: igneous, which is formed by cooling from a molten state; sedimentary, formed by the accumulation and cementing of existing particles and remains of plants and animals; and metamorphic, formed from existing rocks that have been subjected to heat and pressure. When the rock is

Table 5-1.-Classification of Pits and Quarries

<u>Type</u>	<u>Material</u>	<u>Primary Use</u>	<u>Operating Equipment</u>
PIT:			
Borrow:	Select soil other than sand and gravel.	Fill for embankments and subgrades.	Scraper, dozer, rooter, power shovel, front loader, or dragline and dump trucks.
Sand or gravel: (Bank or Hill)	Sand and gravel with clay.	Base course, subbases, and fills.	Scrapers or power shovel, front loader, or hand tools and dump trucks.
(Alluvial)	Clean sand and gravel.	Aggregates for concrete and bituminous mixes and free-draining, nonfrost susceptible fills.	Power shovel, front loader, dragline, or clamshell and dump trucks.
Miscellaneous: (Dumps)	Slag, mine tailings, cinders, etc.	Surfacing, tills, and aggregates.	Power shovel, front loader, or hand tools and dump trucks.
QUARRY:			
Hard rock	Hard, tough rocks like granite, felsite, gabbro, diorite, basalt, quartzite, and some sandstones, limestones, and dolomites.	Aggregates for base courses, surfacing, concrete and bituminous mixes, free-draining tills and stone for riprap, embankments, and marine structures.	Rock drill, blasting materials and machine, power shovel, front loader, dump trucks, and crushing, screening (and washing) plant.
Medium rock:	Moderately hard, tough rocks like most sandstones, limestones, solomites, and marbles.	Base courses and surfacing on roads and airfields and aggregates for some concrete and bituminous mixes.	Rock drill, blasting materials and machine, power shovel, front loader, dump trucks, and crushing, screening (and washing) plant.
Soft rock:	Cementaceous materials like limerock, coral, caliche, tuff, and laterite or weak rocks like disintegrated granite and some sandstones or conglomerates.	Fills and base courses and surfacing for roads and airfields.	Rooter, power shovel, front loader, and earth moving equipment.

exposed to the atmosphere, it undergoes a physical and chemical process called WEATHERING, which, over a sufficient length of time, disintegrates and decomposes the rock into a loose, incoherent mixture of gravel, sand, and finer material.

Soil Quality

The intended use of the soil is the determining factor in the quality required. In general, soil used for fills and subgrades do not have to meet the same specifications as those used for compacted rock surfaces, base courses, or pavements.

Seven properties of rock are used to help select rock and aggregates for construction. Briefly, these rock properties are as follows: toughness, hardness, durability, chemical stability, crushed shape, surface character, and density. Toughness, hardness, and durability are commonly checked in the field with a simple field test.

Hardness is the resistance of a rock to scratching or abrasion. This property is important in determining the suitability of aggregate for construction. Hardness can be measured using the Moh's scale of hardness (table 5-2). The harder the material, the higher its number on the Moh's scale. Any material will scratch another of

equal or lesser hardness. In the field, hardness may be measured using the common expedients shown in table 5-2; for example, when you are able to scratch a rock with a knife blade, the rock has a hardness of 5.0 or less. A rock which can be scratched by a copper coin has a hardness of 3.0 or less.

Aggregates for general construction should have a hardness of 5 to 7 and should be difficult or impossible to scratch with a knife. Material with a hardness greater than 7 should be avoided since they cause excessive wear to crushers, screens, and drilling equipment. Material with a hardness of less than 5 may be used if other sources of aggregate prove uneconomical.

The requirements as to toughness, durability, crushed shape, and other properties vary according to the type of construction. Chemical stability has specific importance when considering aggregates for concrete. Several rock types contain impure forms of silica that reacts with alkalis in cement. This reaction forms a gel that absorbs water and expands to crack or disintegrate hardened concrete. These reactive materials may be included in some gravel deposits as pebbles or as coatings on gravel. Potential alkali-aggregate reactions may be anticipated in the field by identifying the rock and comparing it to known reactive types or by investigating structures in which the aggregate has been used. Generally, light-colored or glassy volcanic rocks, chert, flints, and clayey rocks should be considered reactive unless proven otherwise.

Table 5-2.-MOH'S Scale of Hardness

Mineral	Hardness
Diamond	10
Corundum	9
Topaz or beryl	8
Quartz	7
Feldspar	6
Apatite	5
Fluorite	4
Calcite	3
Gypsum	2
Talc	1
Expedients	
Porcelain	7.0
Steel file	6.5
Windowglass	5.5
Knife blade	5.0
Copper coin	3.0
Fingernail	2.0

An additional property of rock is gradation (fig. 5-1). This property is also important for evaluating rock as possible construction material. Gradation is the distribution and range of particle sizes that are present in, or can be obtained from, a deposit. The gradation of pit materials can be readily determined from a simple test. Quarry materials may be more difficult to evaluate.

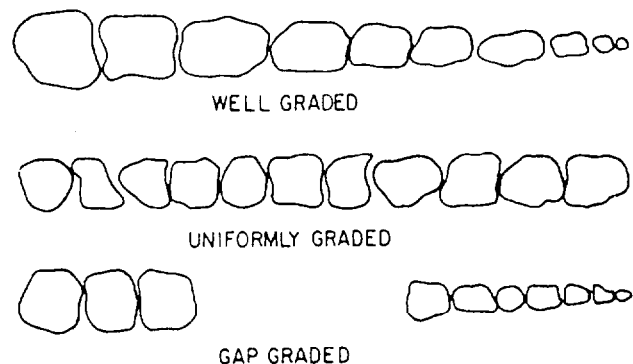

Figure 5-1.-Types of soil gradation.

MAJOR DIVISIONS		LETTER	SYMBOL		NAME
1	2		HATCHING	COLOR	
		3	4	5	6
COARSE-GRAINED SOILS	GRAVELS AND GRAVELLY SOILS	GW		RED	GRAVEL OR SANDY GRAVEL WELL GRADED
		GP			GRAVEL OR SANDY GRAVEL POORLY GRADED
		GM		YELLOW	SILTY GRAVEL OR SILTY SANDY GRAVEL
		GC			CLAYEY GRAVEL OR CLAYEY SANDY GRAVEL
	SANDS AND SANDY SOILS	SW		RED	SAND OR GRAVELLY SAND WELL GRADED
		SP			SAND OR GRAVELLY SAND POORLY GRADED
		SM		YELLOW	SILTY SAND OR SILTY GRAVELLY SAND
		SC			CLAYEY SAND OR CLAYEY GRAVELLY SAND
FINE-GRAINED SOILS	SILT AND CLAY SOILS (LOW LIQUID LIMIT)	ML		GREEN	SILTS, SANDY SILTS, GRAVELLY SILTS, OR DIATOMACEOUS SOILS
		CL			LEAN CLAYS, SANDY CLAYS, OR GRAVELLY CLAYS
		OL			ORGANIC SILTS OR LEAN ORGANIC CLAYS
	SILT AND CLAY SOILS (HIGH LIQUID LIMIT)	MH		BLUE	MICACEOUS SILTS, DIATOMACEOUS SOILS, OR ELASTIC SILTS
		CH			FAT CLAYS
		OH			FAT ORGANIC CLAYS
FIBROUS ORGANIC SOILS	P1		ORANGE	PEAT, HUMUS, AND OTHER ORGANIC SWAMP SOILS	

Figure 5-2.-Conventional graphic soil symbols.

Normally, the upper limit of particle sizes available is controlled by the thickness of rock layers and the spacing of cracks or fractures in the rock. The amount of fine particles produced during rock crushing operations can be highly variable. Generally, hard, tough rocks produce few fines, and soft, weak rocks produce large quantities of fines. Weak sandstones and granites usually produce large amounts of sand-size materials.

Types of Quarry Material

Natural sand and gravel are not always available, and it is sometimes necessary to produce aggregate by quarrying and processing rock. Quarrying normally is performed only where other materials of adequate quality and size cannot be obtained economically.

Many rock types suitable for construction exist throughout the world; therefore, the quality and durability of the rock type selected depends on local conditions. The following rock types are generally easy to quarry, durable, and resistant to weathering. When these are not available, it may be necessary to use softer rocks for base courses and surfacing on a temporary basis. The softer

rocks will usually require little or no blasting.

Granite. As a dimension stone, granite is fairly durable and has a texture and color desirable for polishing. As a construction material for base courses and aggregate, it is not as desirable as some of the more dense, fine-grained igneous rock.

Felsite-Rhyolite. This is durable and makes a good aggregate for base courses. It is not suitable for concrete aggregate.

Gabbro-Diorite. Gabbro and diorite both have good strength and durability. The mineral crystals of both rocks are deeply intermeshed, making them very tough and excellent for construction aggregate.

Basalt. The dense variety of basalt, when crushed, is excellent for use as a base course. It is very strong and durable.

Sandstone. Few sedimentary rocks are desirable for construction due to their variable physical properties; however, sandstone is generally durable. Because of the variable nature of the types of grains and cement, each deposit must be evaluated individually.

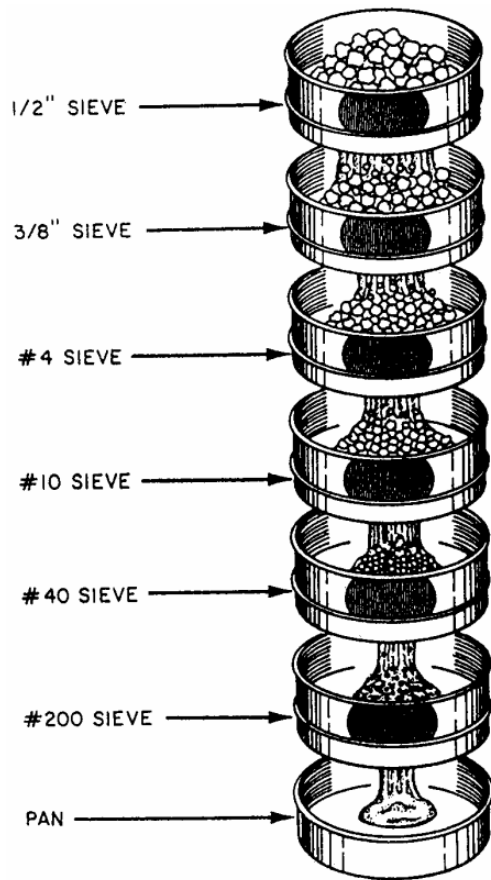

Figure 5-3.-Sieve sizes.

Limestone. Limestone is widely used for road surfacing, in concrete, and for lime.

Gneiss. Most varieties of gneiss have good strength and durability and make good road aggregates.

Quartzite. Quartzite is both hard and durable. Because of these qualities, it is an excellent rock for construction, although it is often difficult to quarry.

Marble. The texture and color of marble make it very desirable for dimension stone, and it can be used for base course or aggregate material.

Sieve Analysis

Soil is composed of particles of various sizes and composition. Figure 5-2 shows the major types of soils. Soil can be analyzed by size by sifting a dried and weighed sample through a set of testing sieves (fig. 5-3) and weighing the material retained on each screen. Further testing may be required by the specifications for the product you need to produce. These tests are normally

performed by the soil laboratory in the engineering department of the battalion.

Soil is classified according to the particle size, such as coarse aggregate, fine aggregate, and mineral filler. The maximum size of the aggregate varies, depending upon the construction specifications. Particle size is defined by passing a soil mass through several sieves with different sized openings (fig. 5-3).

Particles that pass through a given sieve are said to be passing that sieve size. Particles that fail to pass through a given sieve are said to be *retained on* that sieve. The sieve permits particles smaller than the opening to fall through and retains the larger particles on the sieve. When you use sieves with screen openings of different sizes, the soil can be separated into particle groups based on size.

A weighted sample of aggregate is placed in the top sieve, and the entire set of sieves (largest on the top, smallest on the bottom) is vibrated either by hand or mechanically. The individual weights are calculated as a percentage of the total weight, as shown in the following example: Assume we take 3,000 grams of soil mass and determine how much aggregate passes each sieve.

Aggregate passing 1/2-inch sieve and retained on 3/8-inch sieve =	720 grams =	24%
Aggregate passing 3/8-inch sieve and retained on No. 4 sieve =	600 grams =	20%
Aggregate passing No. 4 sieve and retained on No. 10 sieve =	450 grams =	15%
Aggregate passing No. 10 sieve and retained on No. 40 sieve =	570 grams =	19%
Aggregate passing No. 40 sieve and retained on No. 200 sieve =	420 grams =	14%
Aggregate passing No. 200 sieve =	240 grams =	8%
		3,000 grams = 100%

The above percentages are one way of expressing the gradation of a sample of aggregate.

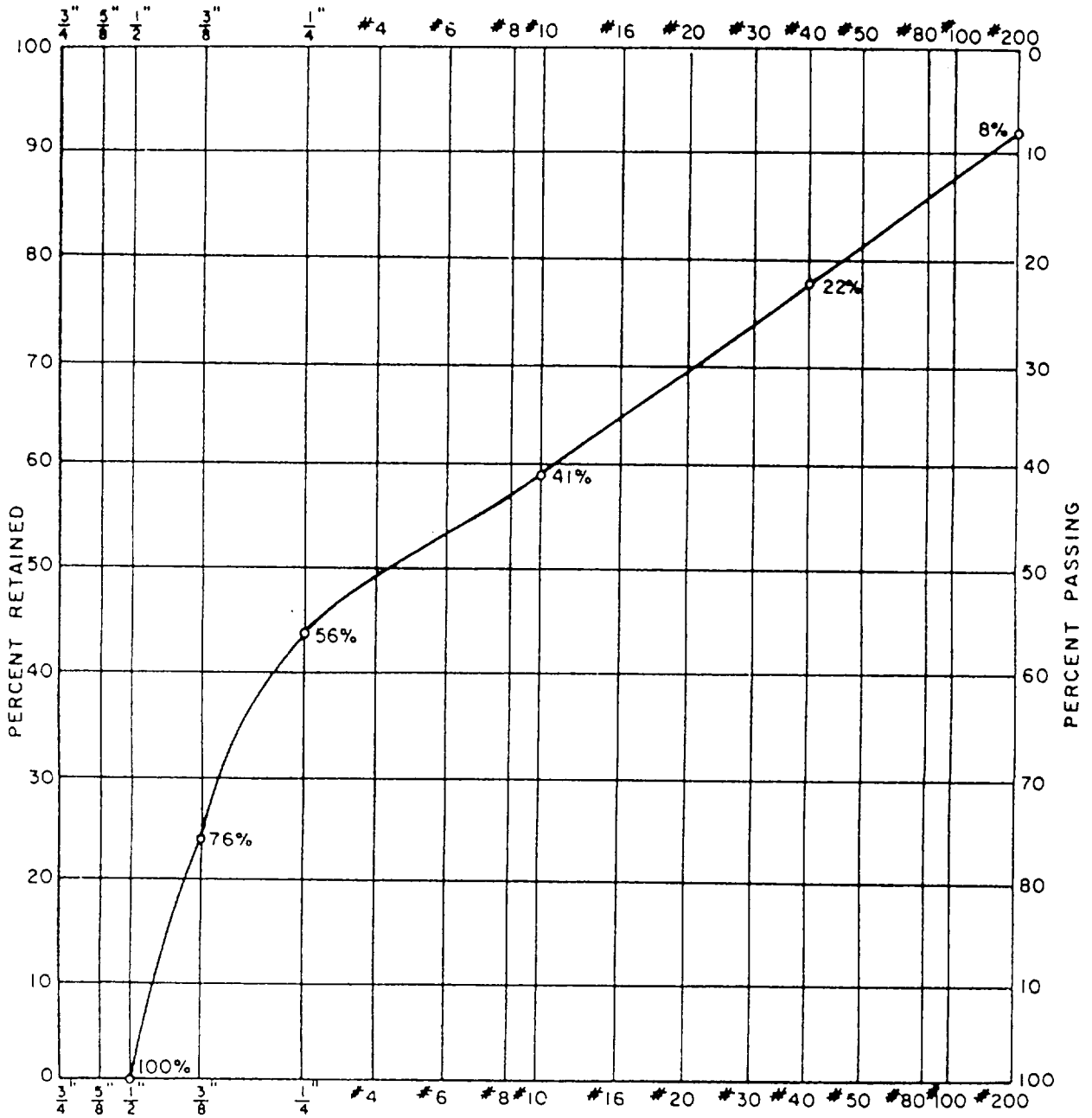

Figure 5-4. Sieve analysis.

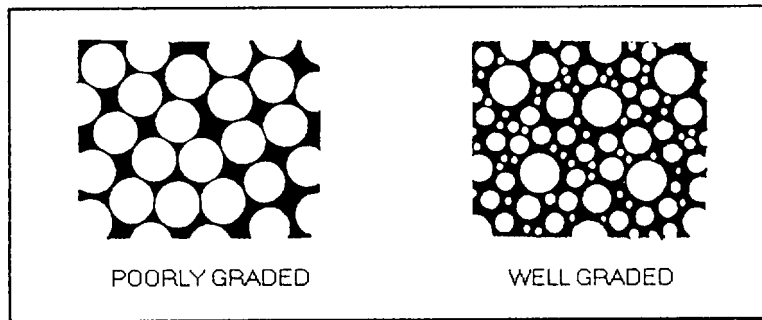

Figure 5-5.—Compactive soil.

Another method, more commonly used, is to express the gradation in terms of the **TOTAL PERCENTAGE** that passes each sieve. This is determined by adding the listed percentage that passed each sieve and was retained on the next finer sieve to the percentages listed beside each of the sieves below it.

For example, in the sample just analyzed, 24% passed the 1/2-inch sieve and was retained on the 3/8-inch sieve. The total percentage that passed the 1/2-inch sieve is 24% + 20% + 15% + 19% + 14% + 8% = 100%

The total percentage that passed the 3/8-inch sieve is 20% + 15% + 19% + 14% + 8% = 76%. Continuing the calculation as indicated, the results of the test in terms of total percentage passing each sieve are as follows:

Aggregate passing 1/2-inch sieve	= 3,000 grams = 100%
Aggregate passing 3/8-inch sieve	= 2,280 grams = 76%
Aggregate passing No. 4 sieve	= 1,680 grams = 56%
Aggregate passing No. 10 sieve	= 1,230 grams = 41%
Aggregate passing No. 40 sieve	= 660 grams = 22%
Aggregate passing No. 200 sieve	= 240 grams = 8%

Figure 5-4 shows the aggregate gradation curve for this particular example, plotted by using the above percentages.

For bituminous aggregate, anything that passes the No. 4 sieve and is retained on the No. 200 sieve is

considered *FINE* aggregate. Anything retained on the No. 4 sieve is considered *COARSE* aggregate.

Material that can pass a No. 200 sieve is sometimes used in bituminous paving; this material is known as *MINERAL FILLER, DUST, OR FINES*. It consists of finely powdered rock, portland cement, hydrated lime, or some other artificially or naturally powdered dust.

All testing sieves larger than three-sixteenths of an inch are identified by the actual clear opening in inches. All testing sieves smaller than three-sixteenth of an inch are identified by mesh number. (See fig. 5-4.)

Compaction Qualities of Soil

Compaction is the process of physically densifying or packing the soil. The strength of any given soil can be increased by the densification obtained from compaction.

Three factors affect compaction: material gradation, moisture content, and compactive effort.

Material gradation (fig. 5-1) refers to the distribution of different sizes of particles within a given soil sample. A well-graded sample contains a good, even distribution of particle sizes. When the composition of a soil sample is made up mostly of one size of particles, this soil would be poorly graded. A well-graded soil will compact more easily than one that is poorly graded. In well-graded material, the smaller particles tend to fill the empty spaces (voids) between the larger particles, leaving fewer voids after compaction (fig. 5-5).

Moisture content is the amount of water present in the soil. Because water acts as a lubricant that helps particles slide into a denser position, the moisture content of a soil is very important to compaction. Water also helps bond clay particles, giving cohesive materials their sticky qualities.

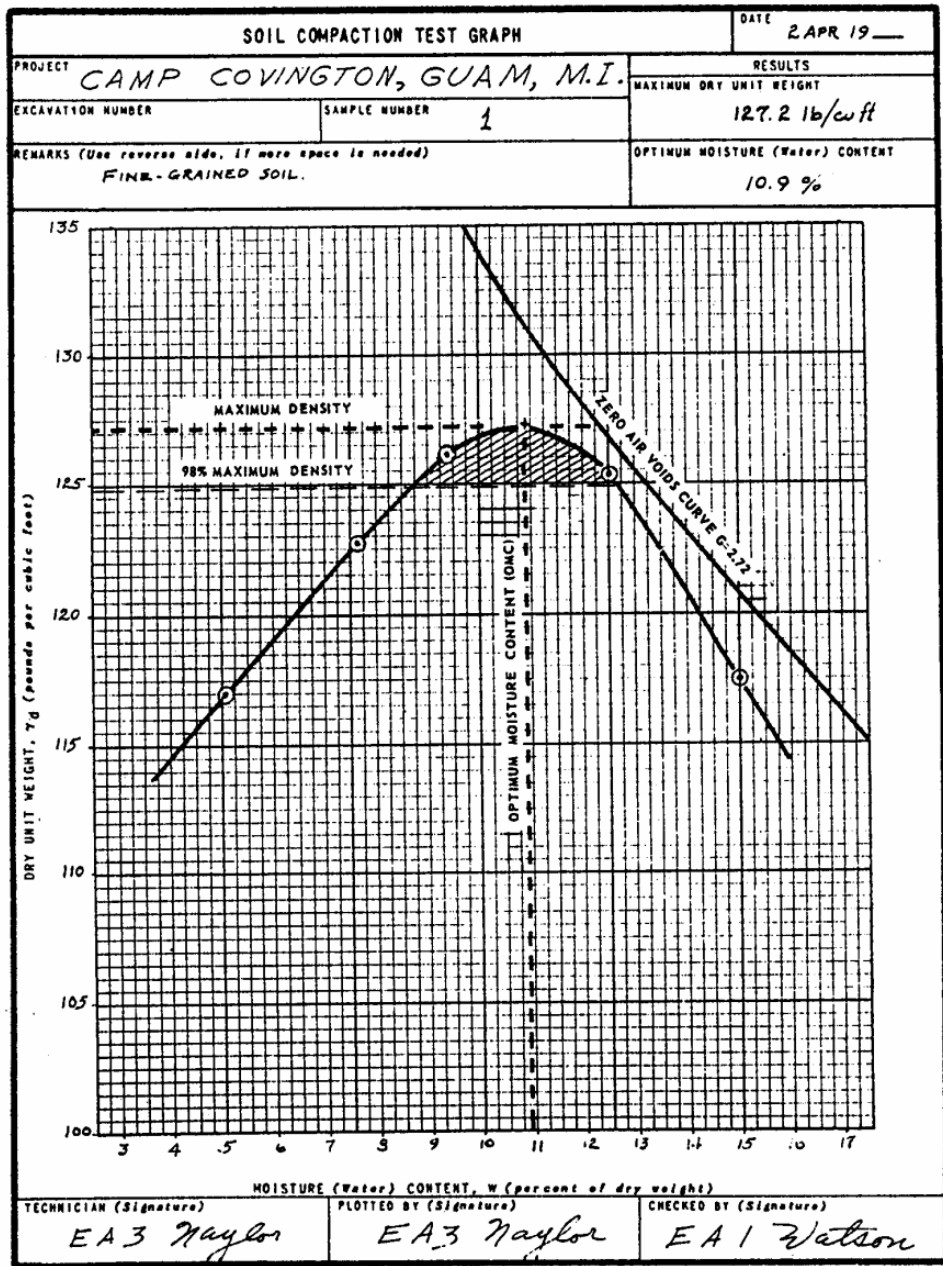

Figure 5-6.—Soil compaction test graph.

Experience has shown it is next to impossible to achieve proper compaction in materials that are too dry or too wet. Soil experts have proved that in every soil there is an amount of water, called the OPTIMUM MOISTURE CONTENT, at which it is possible to obtain maximum density with a given amount of compaction. Figure 5-6 is an example of a compaction curve that is used to show the relationship between dry density and moisture content. The soil laboratory performs and determines the optimum moisture content.

Compactive effort is the method by which the compactor imparts energy into

the soil to achieve compaction. Compactors are designed to use one or a combination of the following types of compactive effort: static weight (pressure), kneading action, impact, or vibration.

PIT OR QUARRY SITE PREPARATION

Preparation of a new site should start immediately after the site location has been selected. Preparatory work includes making an operations plan, clearing the site, removing overburden, draining the site, building

roads, loading ramps, and installing processing equipment.

Operations Plan

The operations plan is prepared before any earth is moved. The plan includes the limits of the site to be developed, methods of excavation, equipment to be used, number of personnel required, and locations of roads, structures, and support equipment. Also, plans for traffic control and drainage are established.

Clearing the Site

When the site is located in a wooded area, the first operation is to clear all timber, standing or fallen. If camouflage is necessary, trees or brush outside the designated cleared area should not be removed.

Construction equipment operations are usually the most rapid and efficient means of clearing a site. Use of the equipment is limited only by unusually large trees and stumps—terrain which hinders their maneuverability and maintenance requirements. The construction equipment used include bulldozers, winches, power saws, rippers, motor graders, and scrapers. In addition, hand tools are used in certain clearing operations.

Brush may be disposed of by burning on the site; however, check to see if a burn permit is required. Timber of suitable dimensions should be stockpiled at the perimeter of the site. This timber should be saved for possible use in construction of loading ramps. All stumps, roots, boulders, vegetation, and rubbish must be excavated and moved clear of the site.

Overburden

Overburden is usually removed from a pit or quarry site by a continuous process of stripping. The methods and equipment used in removing overburden are dependent upon the type of excavation planned, the depth of overburden, and the distance the overburden must be moved. It may be advantageous to leave in place the overburden at military quarry sites and blast it with the rock to provide binder for road building materials. Removal is coordinated with excavation to provide a continuously cleared area. The spoil should be dumped in a remote area to avoid double handling. On hillside locations, the spoil should be placed in banks, located on the downhill side, outside the working area.

Remember that all overburden is not necessarily waste. Some of the overburden is suitable for filling,

building access roads, and leveling stockpile and equipment sites.

In excavating aggregates for concrete, bituminous mixtures, or base courses, the overburden must be removed while the aggregates are processed. Frozen material is loosened either with a ripper or explosives. Overburden should be kept cleared at least 50 feet back from the top of the face of a quarry or pit to prevent rock and other material from falling on personnel working near the top of the face. Also, overburden should be cleared far enough back from the top so the equipment being used to clear the overburden does not interfere with drilling operations.

Drainage

Adequate drainage is essential to the operation of a pit or quarry. Alluvial gravel pits may be worked wet or dry, depending on water levels. Borrow pits and quarries are normally worked dry.

Drainage facilities are installed as early as possible so the site will be dry when work starts. The means of drainage depends primarily upon the location and the amount of water to be eliminated. Hillside locations are easy to drain by an interceptor ditch made along the uphill side with a scraper, dozer, or grader. When the floor of a site is belowground level, both surface and seepage water must be disposed of. When open ditches cannot be dug to take advantage of gravity flow, all water is directed to a sump hole. A slight slope on the site floor must be maintained at all times to permit water to drain away from the working face of the site.

Roads

Construction of access roads should start as soon as the operations plan is completed so they are ready for use when the pit and quarry equipment arrives. The access roads should be designed for all-weather operation under the heaviest loads anticipated. The roads should follow the shortest and easiest routes that satisfy the traffic control plan. To speed up hauling, you must avoid sharp curves and grades kept as low as possible. Ten percent grade (10-foot drop or climb every 100 feet) is the maximum grade for truck operations, whereas tractors and graders can climb 20-percent grades for short distances.

Except for the loop at the loading site, access roads should provide one-way traffic—one route to enter and another to haul out. Leave enough space between haul roads and borrow pits to avoid traffic hazards.



Figure 5-7. Plain chute loading ramp.

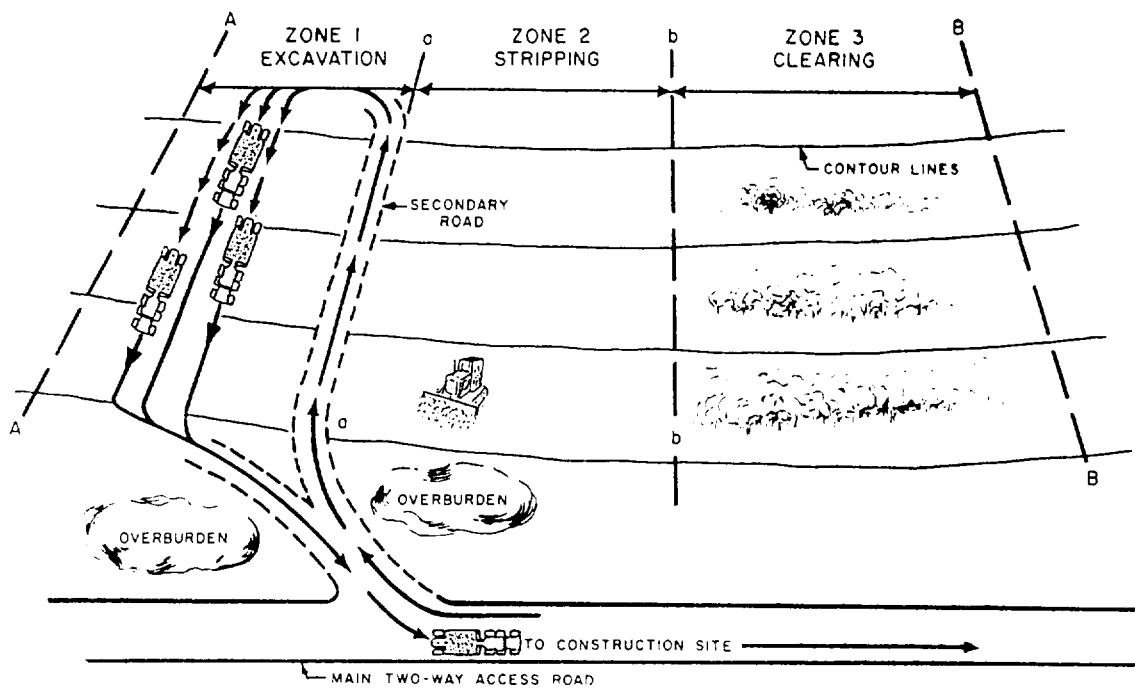

Figure 5-8. Layout and development of a scraper pit.

Chute Loading Ramps

A chute loading ramp is an expedient means of loading excavated material into trucks with earth moving equipment at sites where loaders and clamshells

are unavailable. An elementary type of loading ramp is the plain chute (fig. 5-7). Each ramp must be able to support the heaviest equipment used, plus an impact factor of 50 percent, and approximately 20 ton; of material.

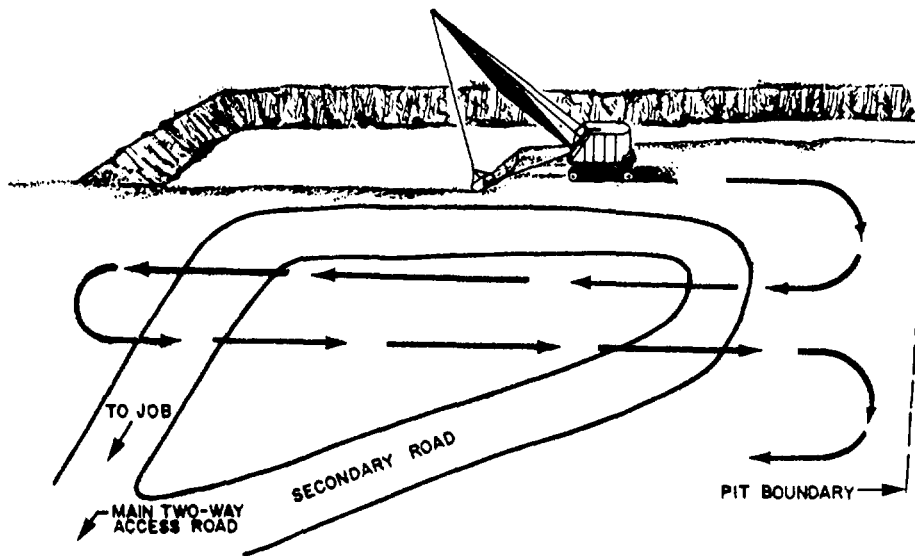

Figure 5-9. Layout and development of a pit, using a dragline.

PIT OPERATIONS

Sand, gravel, and other construction materials are extracted from pits with scrapers that can move huge volumes of material in a relatively short period of time. The material is removed from the floor of the pit in successive thin layers over its entire width.

During excavation, scrapers should be carefully spotted to maintain an even downgrade and prevent cutting holes below the general level of the pit floor. When the pit is longer than 100 feet in the direction of loading, the scraper spots should be staggered along the length of the cut as well as across the width of the zone. Figure 5-8 depicts the layout and development of a scraper pit with lines A-A and B-B showing the limits of the pit. Lines A-A and B-B divide the area into three zones for current excavating, stripping, and clearing. Zone 1 is being excavated at the same time Zone 2 is being stripped and Zone 3 is being cleared. Three scrapers in staggered formation load downhill in Zone 1, and a dozer strips downhill in Zone 2.

In consolidated gravel or soft rock, when scrapers assisted by pusher tractors (Push Cat) will not pickup a heaping load within 150 feet, a ripper should be used to loosen the material, thereby increasing the loading efficiency of the scrapers. Rippers should be operated downhill, and an entire zone should be ripped at one time while the scrapers are hauling from another zone.

The dragline is the most practical piece of construction equipment for underwater digging and is particularly adapted to submerged gravel pit operations. Draglines can efficiently recover sand, gravel, laterite, or coral from beaches, the beds of streams, and the bottoms of lakes and lagoons. Figure 5-9 depicts the layout and development of a pit being excavated with a dragline.

Clamshells are capable of excavating loose sand, gravel, and crushed stone at, above, or below ground level. The clamshell can be raised and loads dumped at heights equal to the distance from the tip of the boom to the ground, minus the length of the clamshell bucket, to allow adequate clearance for the bucket when it is opening.

Material removed from pits can seldom be used in its in place state. In most cases, pit material must be processed (crushed and screened) to meet job specifications. But, before the material can be processed, it must be loaded and delivered to the processing equipment. Loading and delivery may require additional handling equipment, such as front-end loaders equipped with either a rollback bucket or 4-in-1 bucket and conveyers that may be used singly or in series to load vehicles, construction equipment, or hoppers from stockpiled material. Bucket loaders may also be used. They consist of a power-driven endless chain to which buckets are attached so material is loaded on the downward travel. Handling equipment is used to

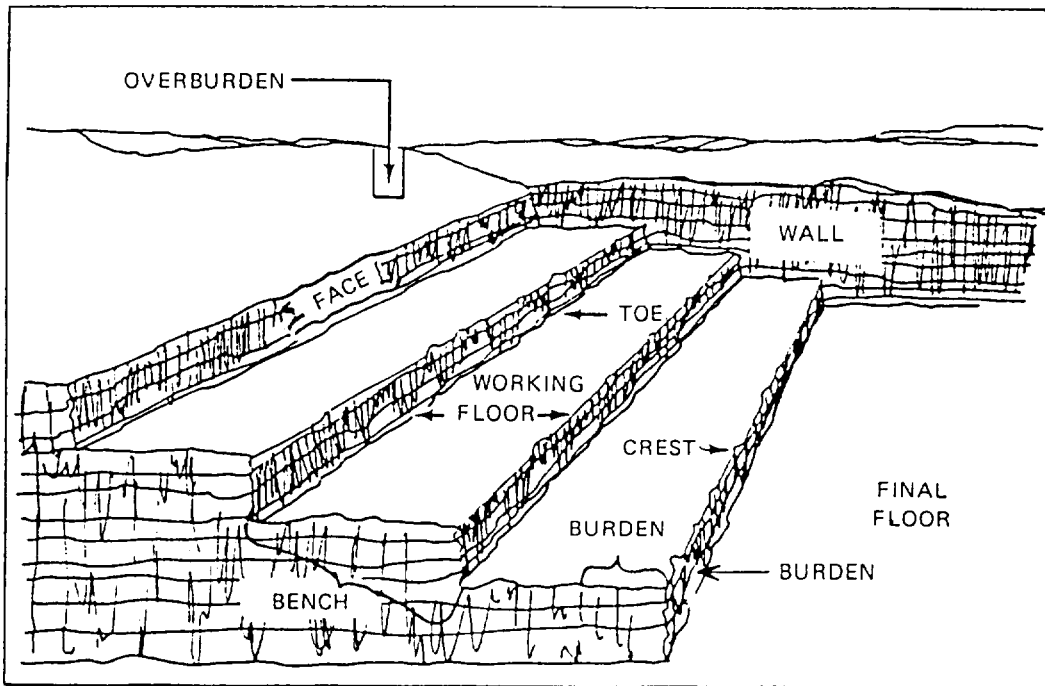

Figure 5-10.-Quarry terminology.

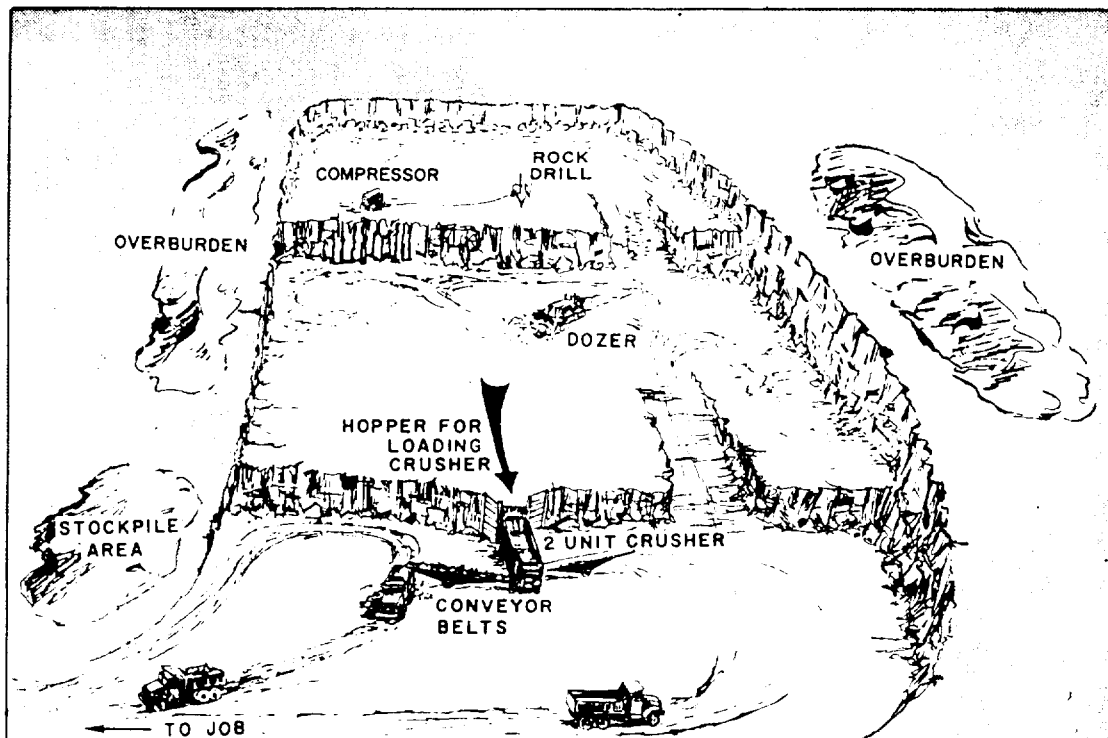

Figure 5-11.-Typical quarry layout.

load stockpiled material into overhead hoppers and trucks.

The production of any pit material that requires crushing and screening depends on the capacity of the processing equipment used.

QUARRY OPERATIONS

Quarrying involves not only extraction of material (rock) but also crushing and screening that makes the rock suitable for use as construction material.

Quarry Terminology

Figure 5-10 shows the names of various quarry features. *Overburden* is the waste material that often overlies pit or quarry sites. Deposits within the waste materials are called spoil and must be removed before excavation of the construction materials lying below. *Overburden* refers to loose material but locally it may include solid rock lying above the desired material. *Burden* is the construction material on the face of a quarry. The *floor* of the quarry is the inside bottom surface that marks the lower limit of excavation. Often quarries contain one or more *working floors* at various levels above the final quarry floor. A *quarry wall* is a more or less vertical surface that marks the lateral limit of excavation. The *face* of a quarry is a rock surface (usually vertical) from which rock is to be excavated. The top of the face is called the *crest*, and the bottom is called the *toe*. A *bench* is a steplike mass of rock behind a face and below a working floor. Notice that each bench has a face, toe, and crest.

Quarry Development

The layout of a quarry should provide a gravity flow of material from the face to the crusher, from the crusher to the storage bin, and from the bin to the hauling equipment, as illustrated in figure 5-11. A quarry laid out in this manner assures that a maximum quantity of rock can be processed with a minimum of labor and equipment. In quarries laid out on the gravity-flow principle, the drainage problem is practically eliminated.

Military quarries are generally of the open-face type with the vertical surface of the rock exposed. Depending

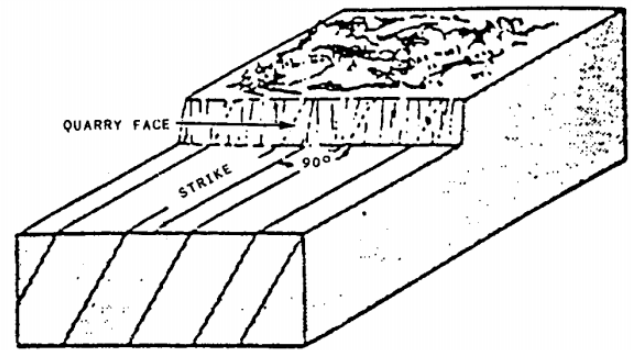

A INCLINED STRATA

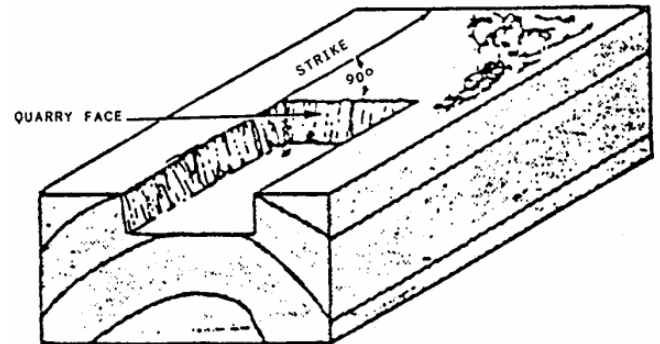

B FOLDED STRATUM (ANTICLINE)

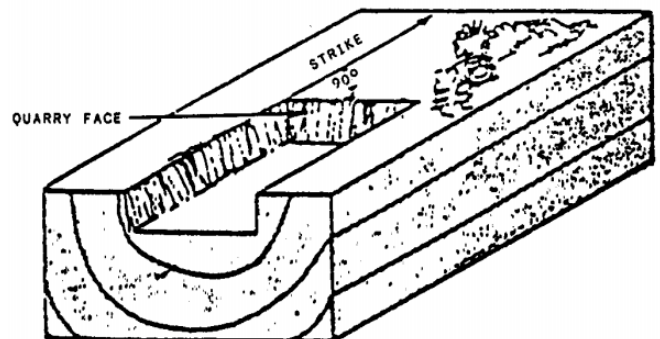

C FOLDED STRATUM (SYNCLINE)

Figure 5-12.-Determining the direction of the quarry face.

upon local conditions, they may be developed by the single- or multiple-bench method.

Where the rock face is not exposed, core samples should be taken in a grid pattern so rock formations can be plotted, and the lay of the strata, the quality and quantity of the deposit, and depth of overburden can be determined. Should a rock formation be jointed or stratified, the layout of the quarry is determined by the strike (direction) of the formation; that is, the face of the quarry must be directed at right angles to the strike (fig. 5-12). This ensures a vertical or near vertical face with less chance of undercutting the face and creating a dangerous overhang.

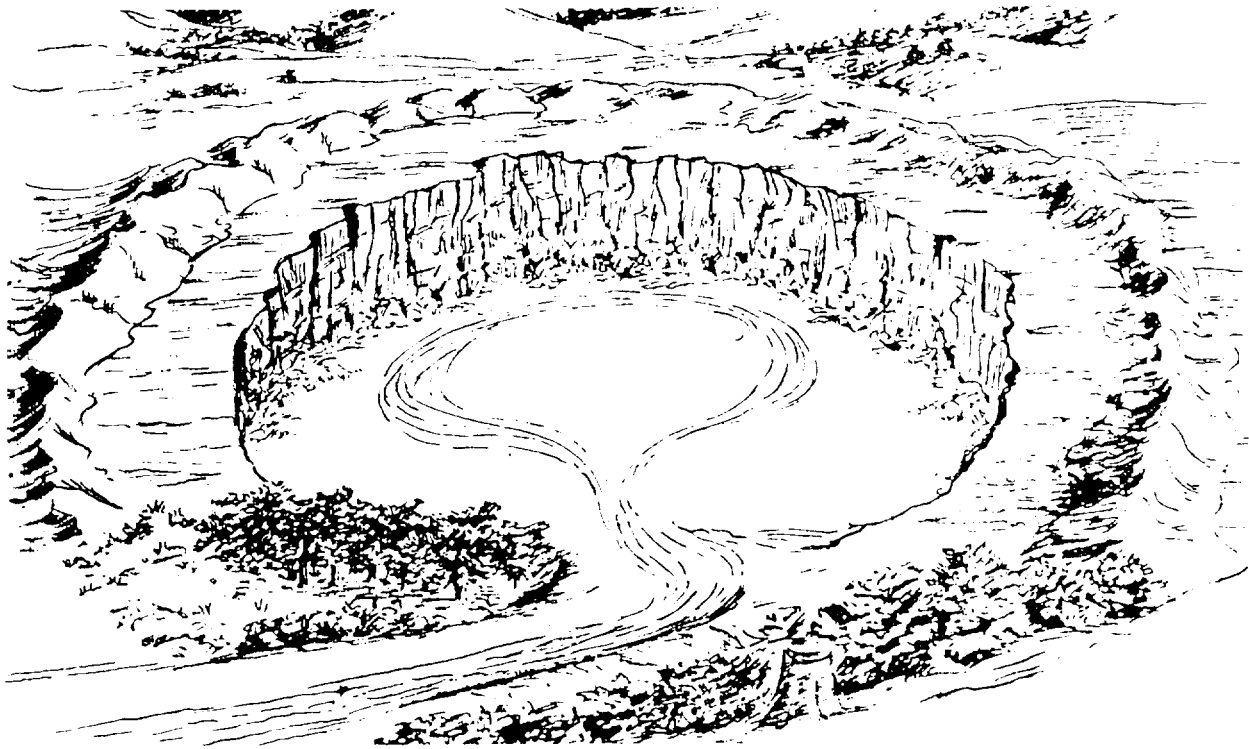

Figure 5-13.-Single-bench quarry.

A single-bench quarry (fig. 5-13) is one having the entire floor on one level. The height of the bench will depend on the reach of the equipment available. In the NCF, the recommended bench height is 10 feet; however, depending on the drilling equipment available, type of rock, magnitude of operation, and experience of the operating personnel, bench heights can range from 8 to 40 feet.

Military quarries are usually of the single-bench type. This type offers greater safety and efficient operation. All operations are on one level, a greater amount of rock is shot at one blast, and less equipment is needed in the overall process. In addition, this type of quarry requires less training for the operating crews.

Blast trial shots are made in both existing and new quarries before installing equipment for two reasons. First, to avoid possible damage to installed equipment and the second, in the case of new quarries, is that the trial shots will provide necessary ballast to construct

access roads and for foundations to place equipment upon.

WARNING

Blasting must be supervised and controlled directly by a qualified blaster. Also, all personnel working around blasting should wear hard hats, safety goggles, dust respirators, earplugs, and hard toe safety shoes.

A multiple-bench quarry (fig. 5-14) is one having a series of ledges or terraces resembling steps. The highest bench is blasted and worked first. Then successive lower levels are simultaneously developed as the work progresses and as each bench is required.

Quarries are developed by the multiple-bench method when the face is too high for single shots, horizontal seams or separations are present, or deep and narrow deposits exist. This method of development permits equipment to be used simultaneously at more

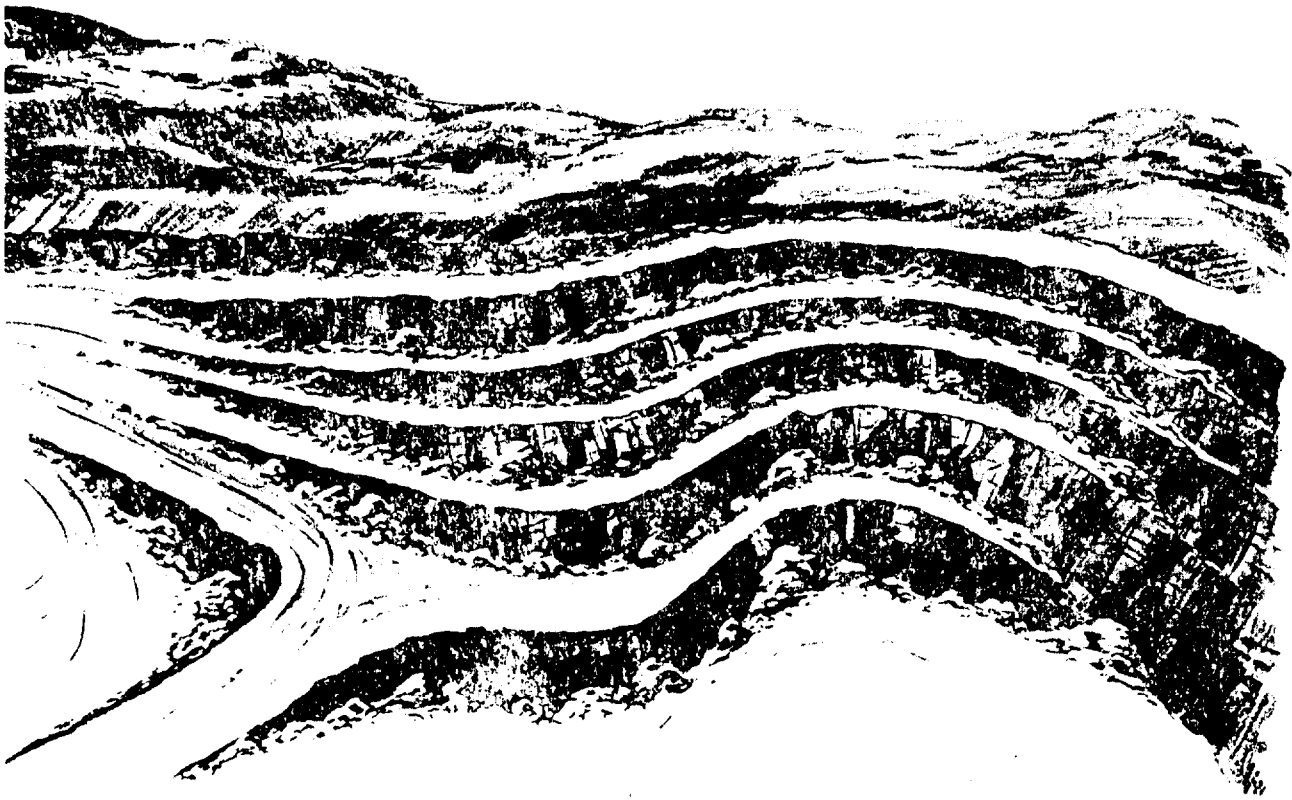

Figure 5-14.-Multiple-bench quarry.

than one level. All benches must be made wide enough to allow the use of equipment to remove blasted rock (50 feet minimum). Multiple-bench quarries make possible greater continuity of operation than single-bench quarries.

NOTE: When you are developing a multibench quarry, blasting must be confined to only one bench at a time. Simultaneous blasting at several levels is NOT permitted under any circumstances.

QUARRY EQUIPMENT

CESE is available in the Naval Construction Force TOA to enable construction units to meet their own aggregate production requirements. Quarry equipment is subject to exceptionally hard wear due to the abrasive action of rock and rock dust; therefore, the operator's maintenance procedures contained in the manufacturer's maintenance and service manuals must be strictly followed.

The equipment used in hard-rock quarries consists of bulldozers, air compressors, rock drills, drill steel and bits, loading and hauling equipment, and miscellaneous tools. As the supervisor in charge of quarry operations, you must ensure that operator's maintenance is performed and that all cutting edges, end bits, teeth and shanks, dozer tracks, tires, blades, and so forth, are checked daily for wear, adjustments, and cracks.

Wearfacing

Equipment used in quarry operations should be wear-faced. Wearfacing greatly extends the usable life of construction equipment, ensures efficient operation with less downtime, and greatly reduces the need for spare parts. Guidelines for wearfacing equipment parts and accessories are outlined in the *NCF Welding Materials Handbook*, NAVFAC P-433.

Wearfacing is commonly known in the NCF as hardfacing. The purpose of hardfacing (fig. 5-15) is to insulate many working parts of equipment from the destructive forces that cause metal wear. The selection of a hardfacing alloy for a certain application is based on the capacity of the alloy to withstand or resist impact and abrasion. Impact refers to a blow or series of blows on a surface that results in a fracture or gradual deterioration. Abrasion is the grinding action that results when one surface slides, rolls, or rubs against another. Under high compressive loads, this action can result in gouging.

Alloys that resist abrasion well are poor in withstanding impact, whereas those that withstand impact well are poor in resisting abrasion; however, there are many alloys whose hardfacing properties fall between two extremes. These alloys offer some protection against abrasion and withstand impact fairly well. The hard-faced welding procedures, the type material the part is manufactured from, and the primary and alternate electrodes to perform the hardfacing procedures are all outlined in NAVFAC P-433. Hardfacing operations must be approved by the maintenance supervisor.

Maintenance

Often, maintenance is put off to a later date because of production. This may satisfy the immediate production demands of the unit, but it is not good for the

equipment and creates a lax attitude toward scheduled maintenance. When this occurs, a precedent is set that leads to putting maintenance second to production. Should this happen, it is not long before production rates decline because of equipment breakdowns.

BLASTING OPERATIONS

Blasting operations are usually necessary when working a quarry containing materials that cannot be removed with construction equipment, such as front-end loaders, bulldozers, and hauling equipment. Should this be the case, blasting will come under the direct supervision and control of a qualified blaster who carries the NEC-5708. All other quarry personnel assigned must follow written and oral instructions, carry out assigned duties, and observe all safety precautions.

Limiting the number of personnel handling explosives lessens the risk of accidents occurring. This means one or two blasters have a definite assignment to conduct several of the tasks involved in loading and firing a blast. These tasks include the following: carrying explosives and detonators, opening cases, priming, loading, stemming, connecting blasting circuits, and firing. The entire quarry crew must know exactly what the blaster's duties are. With such a system observed, everything is accomplished in a precise and orderly manner with no haphazard assumption of the various tasks to be performed.

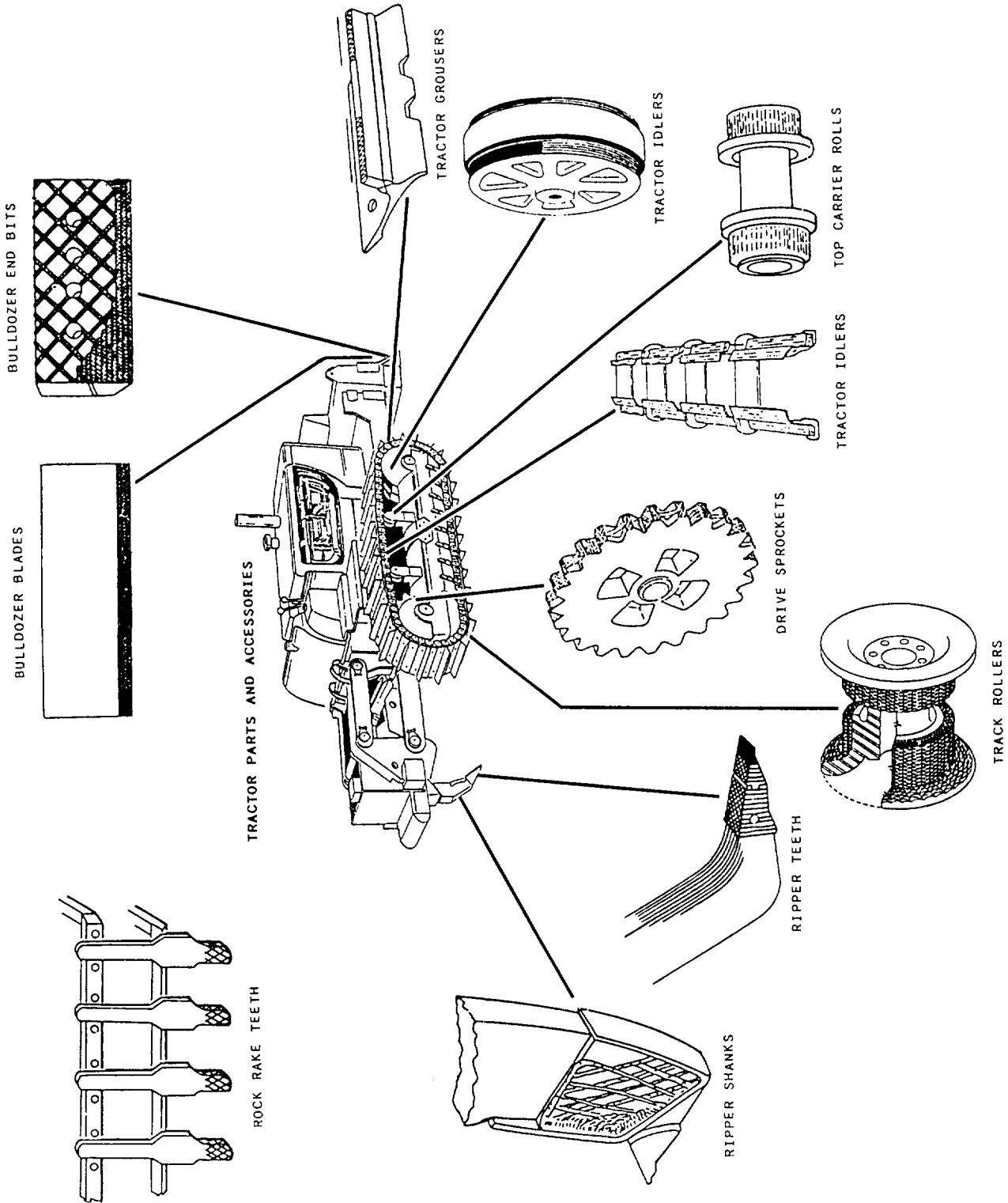

Figure 5-15.—Hard-faced parts and accessories.

CHAPTER 6

CRUSHER SUPERVISOR

Equipment is provided by the Naval Construction Force (NCF) to enable the Seabees to meet aggregate production requirements. Of this equipment, crushing equipment is the critical item that provides the capability to reduce and process material from a *pit* or *quarry* to produce finished aggregate in sufficient quality and quantity to meet construction requirements.

Seabees are tasked with crusher operations in both Pacific and Atlantic fleet deployment sites. The Naval Construction Training Center (NCTC), Port Hueneme, California, provides training for crusher operations; however, the majority of training in this area is achieved through on-the-job-training (OJT).

The *COMSECOND/COMTHIRDCB* direct the tasking of crusher operations conducted by the Naval Mobile Construction Battalions (NMCBs). The NMCBs schedule a predetermined number of man-days for crushing a variety of sizes and volumes of material used to support construction projects, concrete plants, crete mobiles, and asphalt plants. At the end of a deployment, each battalion involved is usually tasked to turn over a specified number of cubic yards of material of various sizes to the relieving battalion. The magnitude of the rock crusher tasking dictates the size of the crew assigned to support the rock crusher operations.

CRUSHER SUPERVISOR RESPONSIBILITIES

In the Naval Construction Force (NCF), crusher operations are usually managed by Alfa company. The Alfa company operations chief is responsible for crusher operations and should assign a crusher supervisor to direct the operations of the crusher. This chapter presents important information an EO must master to gain the basic knowledge of rock crusher operations required to perform the duties of a crusher supervisor.

ROCK CRUSHER

Crushing plants are classified by their capacity output. The most often used plant, classified medium-to-large, has a rated capacity of 75 tons per hour (tph). This plant has two separate and distinct sets of equipment: the primary unit and secondary unit.

The primary unit reduces the quarry rock or coarse gravel by crushing. The secondary unit is primarily used to process the crushed product.

The amount of crushing required to produce a suitable amount of aggregate material depends upon the availability of raw materials and the specifications established for the end product. In any crusher operations, there are four basic functions that have to be accomplished. The four functions are as follows:

1. Particle size reduction by crushing.
2. Separation into particle size ranges by screening.
3. Elimination of undesirable materials by washing.
4. Movement of the material from one location to another.

Primary Unit

The primary unit (fig. 6-1) consists of a 20-inch by 36-inch standard type of jaw crusher (fig. 6-2), a vibrating grizzly, an under crusher delivery conveyor, and a running gear. The jaw crusher can be powered by a diesel engine or by electrical power. All other components are driven by individual electric motors. Normally, power is supplied by a 200-kW diesel generator. The running gear is equipped with a fifth wheel and towing dolly.

CAUTION

Make certain each electrically powered component is grounded.

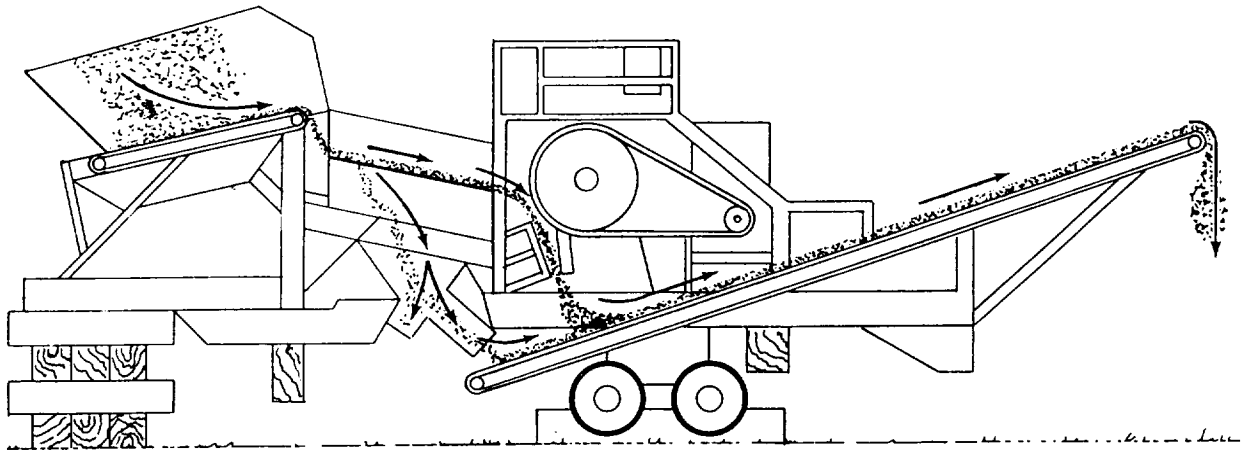

Figure 6-1.-Primary unit.

Most crusher and screening units plants are equipped with some type of feeder to regulate the flow of material into the crusher unit. A heavy-duty apron type of feeder (fig. 6-3) is usually used to feed the primary crusher. Raw materials from the pit or quarry are deposited into the hopper of the heavy-duty apron feeder that moves the material onto the deck of the vibrating grizzly. The rate of flow of the feeder belt is controlled by the operator using the **START** and **STOP** buttons located on the control panel.

As material is moved out of the apron feeder, it is processed across the vibrating grizzly. The deck is normally a bar type of screen with a 1 1/2-inch fixed opening. It screens out material smaller than 1 1/2 inches and routes the oversized material through the jaw chamber to be crushed. The undersized material is routed through a chute to the undercrusher conveyer. From this point the material can join the jaw crusher product by closing a flop gate. This material can be directed through another chute (by closing a flop gate) and routed to a by-product stockpile.

The vibrating grizzly prescreens material that is already down to size, allowing the material to bypass the jaw crusher. The grizzly also dry-cleans the material by vibrating it vigorously. The flop gates on the grizzly enable the operator to select and decide what to do with smaller particles.

Oversized material is routed through the jaw crusher where it is gradually reduced in size by a series of elliptical- downward crushing strokes and is then discharged onto the undercrusher delivery conveyer belt. The product size is determined by the product setting adjustment made at the discharge end of the jaw plates.

The hourly rate of production to be obtained from a given size jaw crusher depends upon a number of variable factors:

1. The toughness of the raw material.
2. The product setting.
3. The reduction ratio. (The size of the material fed to the crusher compared to the product size.)

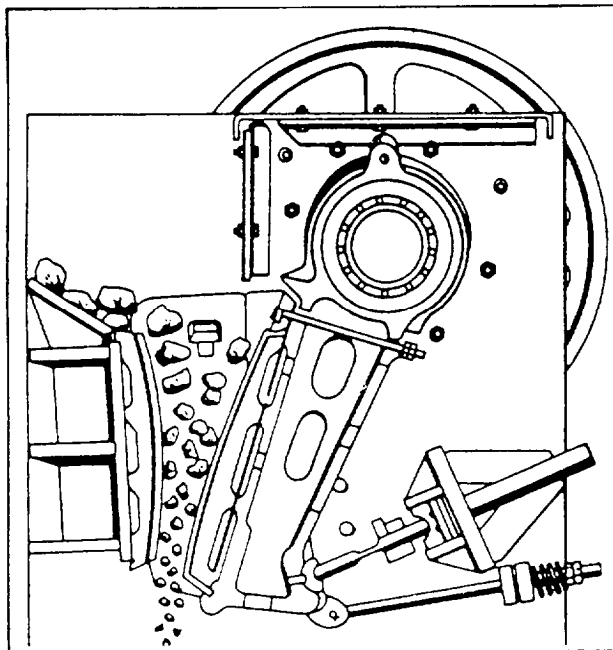

Figure 6-2.-Jaw crusher.

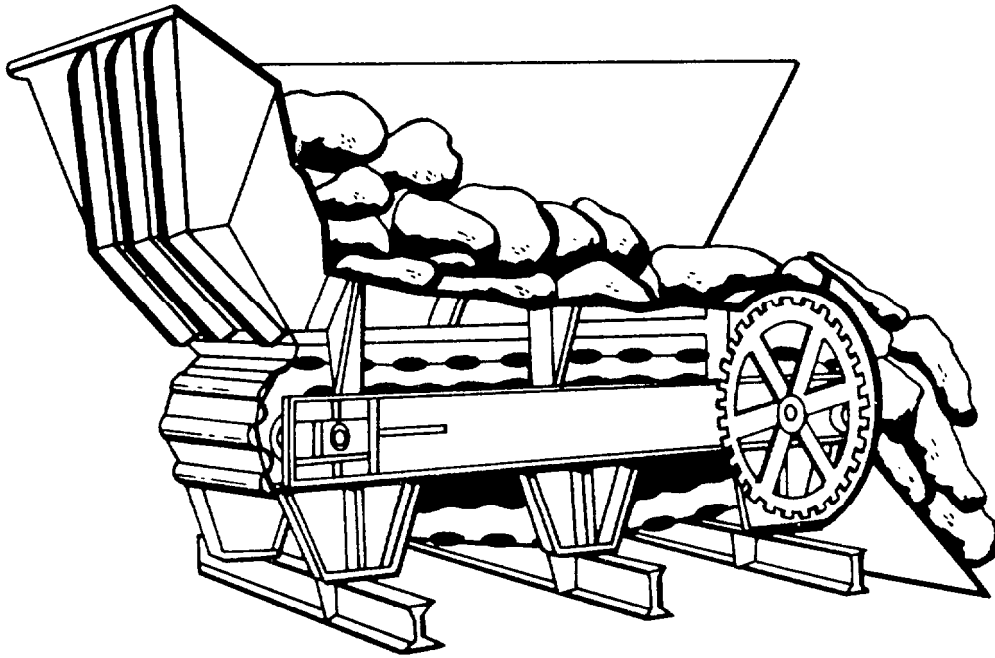

Figure 6-3.-Apron feeder.

4. The gradation of raw material.
5. The extent of wear to the corrugated surfaces of the jaw plates.
6. The rate of feeding.

Feeding problems may develop due to irregular shapes and unwieldy nature of quarry run rock. Feeding problems can drastically reduce production. Some common problems are blocking, bridging, choking, and packing.

Blocking occurs when an oversize rock settles over the jaw opening and stops the flow of incoming material. The jaw continues to operate but no crushing takes place. To prevent blocking, you should let the maximum size of material processed be 2 inches less than the jaw crusher size. Blocking can be controlled or eliminated by using a scalping grizzly to prescreen material. *For optimum production, the ideal feed size is 75 percent of the jaw size.*

Bridging occurs when two rocks, within the maximum size, arrive at the same time. The two rocks interlock and bridge the jaws open. When this occurs, all production stops. When large rocks approach the opening, they should be fed individually to prevent bridging.

Choking occurs when the jaw chamber is continually overfilled. This creates an overload

condition and causes the engine to lug down and may damage the equipment. For optimum production, the operator should try to keep the jaw chamber 75 percent full.

Packing occurs when feed material cakes and packs in the crusher chamber. Plastic material, such as clay, may become sticky and cause this problem. Packing can become so severe that it completely stops production. Packing can be reduced or eliminated by prescreening or prewashing the material. In most cases, the most practical solution is to wet down the material thoroughly. Then process the material even though it is almost in the form of a slurry.

The jaw crusher can produce at a rate of 55 to 185 tph, depending upon the product setting and the toughness of the material being crushed. The maximum product setting is 5 inches, and the minimum setting is 1 1/2 inches.

WARNING

Keep all parts of your body out of the jaw cavity when you are operating or adjusting the jaws.

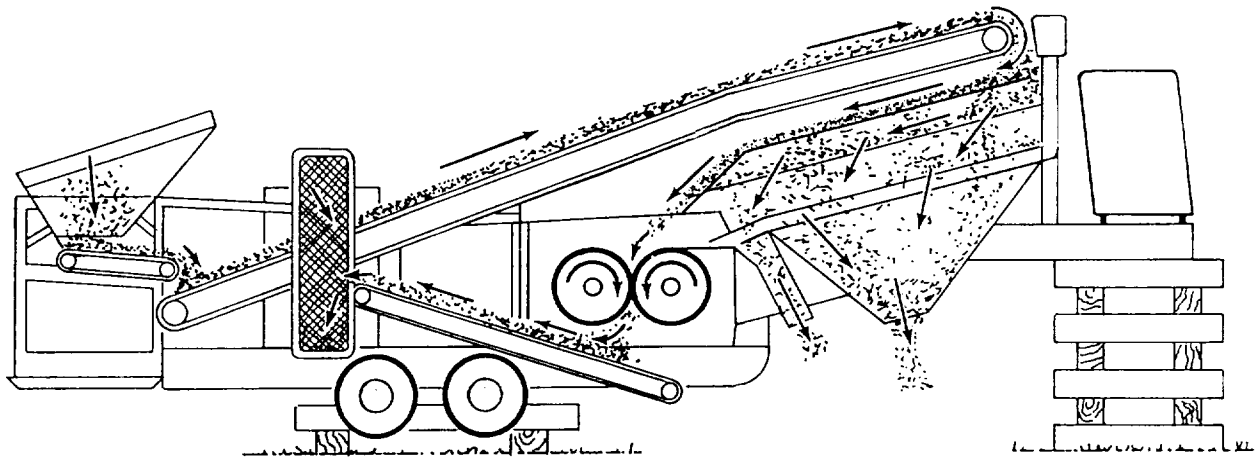

Figure 6-4. Secondary unit.

Secondary Unit

The secondary unit (fig. 6-4) consists of a reciprocating feed hopper, an overcrusher conveyer, a two-deck vibrating screen, a *dual roll crusher* (fig. 6-5) or *hydrocone crusher* (fig. 6-6), an undercrusher return conveyer, a revolving elevator wheel, a diesel power unit, and the running gear. The dual roll or hydrocone crusher can be driven by a diesel engine or an electric motor. All other components are driven by individual electric motors and power is normally supplied by a 200-kW generator.

Material to be processed is introduced into the hopper of the reciprocating feeder. The rate of flow is controlled by the adjustable gate opening. Material is deposited onto the overcrusher conveyer and carried to the feed end of the top screen. Material that has been crushed down to product size by the jaw crusher passes the top screen. Oversized material is retained on the top screen and directed through a *dual roll crusher* or *hydrocone crusher* for further reduction.

The *dual roll crusher* consists of a set of rolls that revolve toward each other at a constant rim speed. Stone particles are reduced in size as they are drawn between the two rolls. Product setting is determined by the

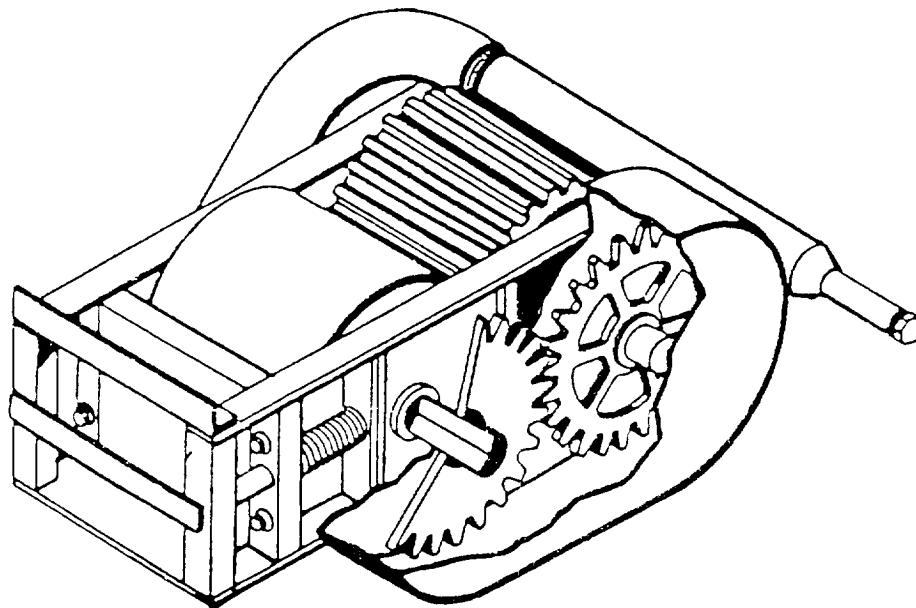

Figure 6-5. Dual roll crusher.

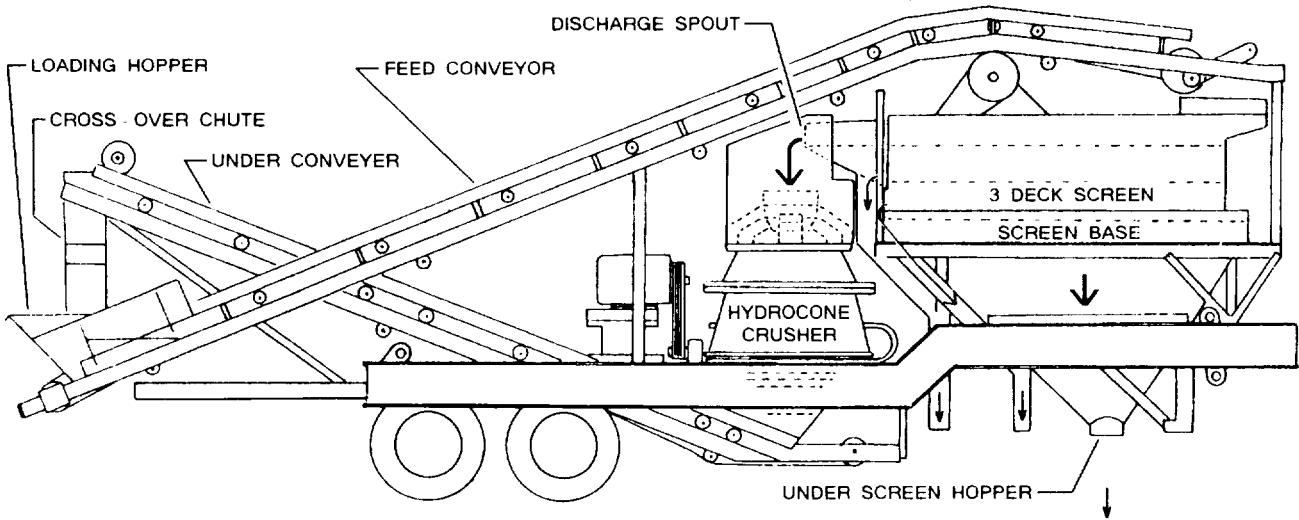
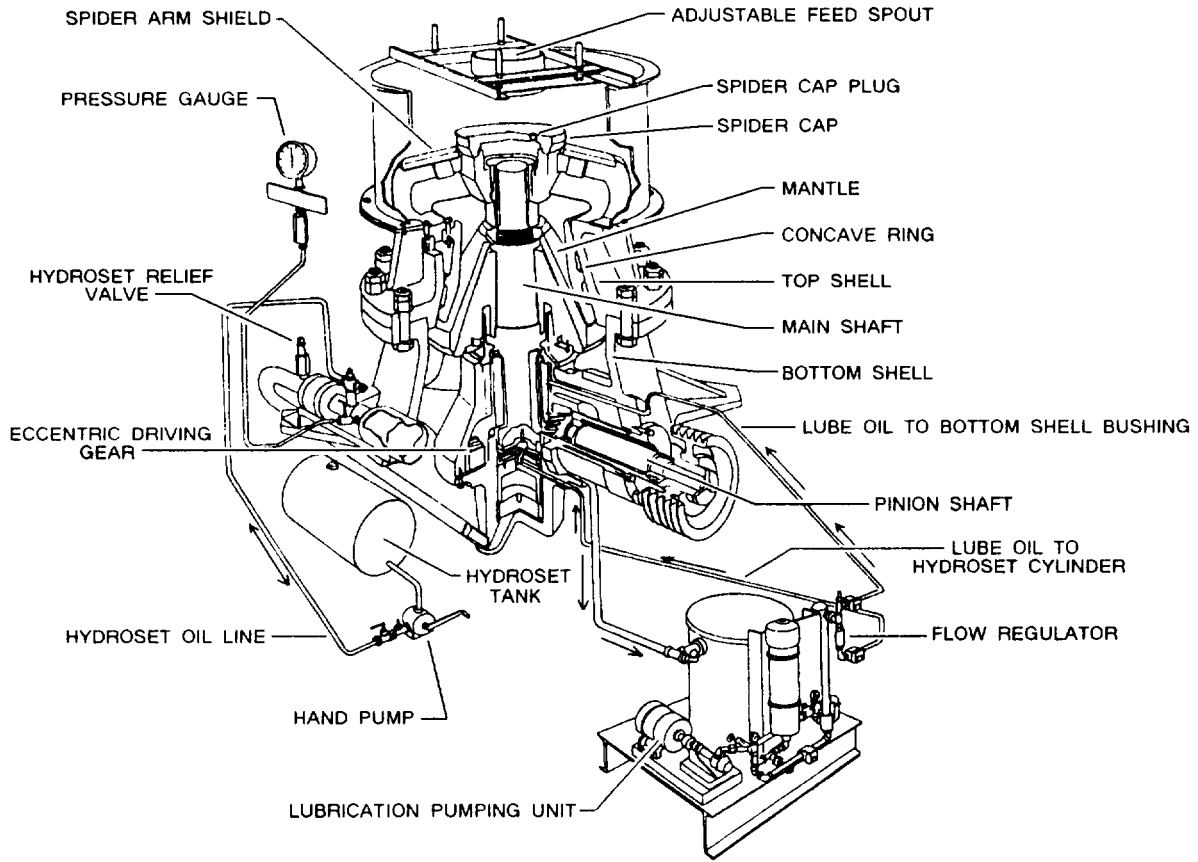

Figure 6-6. Cone crusher plant.

spacing between the rolls. It is necessary to set the opening between the rolls slightly closer than the top product size required. With two coarse corrugated shells (fig. 6-7), the tip-to-tip setting produces a product larger than two smooth shells set at the same distance.

In the NCF, the *hydrocone crusher* is normally used as the secondary unit. These machines have a conical or domed crushing member called a cone, head, or sphere, which moves in a small circle around a vertical axis inside a fixed bowl or mantle.

The cone may be relatively stationary at the top and move at the bottom only, or be mounted so that the head can wobble as well as gyrate. The crushing head is free to turn under the thrust from the material being crushed. The fineness of the product is adjusted by raising or lowering the mantle.

Effective feed and discharge arrangements are essential to the operation of any cone type of crusher. For maximum crushing efficiency, feed must be supplied to the crushing chamber in the optimum amount and distributed evenly around the entire crushing area.

NOTE: Material received by the *hydrocone crusher* must be evenly distributed

nonsegregated feed. This means that the material entering the crusher is evenly distributed around the entire crushing chamber, with fine and coarse material well intermixed in the feed. Unevenly distributed or segregated feed results in poor manganese wear, reduced capacity, and high stresses within the crusher. These problems can cause short bearing life and possible failure of major components. An evenly distributed, nonsegregated feed results in maximum capacity, a uniform product, and a smooth running machine.

A pressure gauge is standard on all *hydrocone crushers*. Erratic hydroset control pressure and motor amperage (horse-power draw) readings are evidence of poor feeding conditions and uneven feed distribution in the crushing chamber. The pressure gauge enables the operator to read high, average, and low pressures in the hydroset control and take corrective measures against erratic and high-pressure conditions. The pressure gauge should be checked regularly when the crusher is receiving the full or maximum amount of feed.

NOTE: When excessive fluctuations occur in the pressure in the hydroset control and horsepower draw, determine and eliminate the cause immediately. Operating the crusher under these conditions can cause

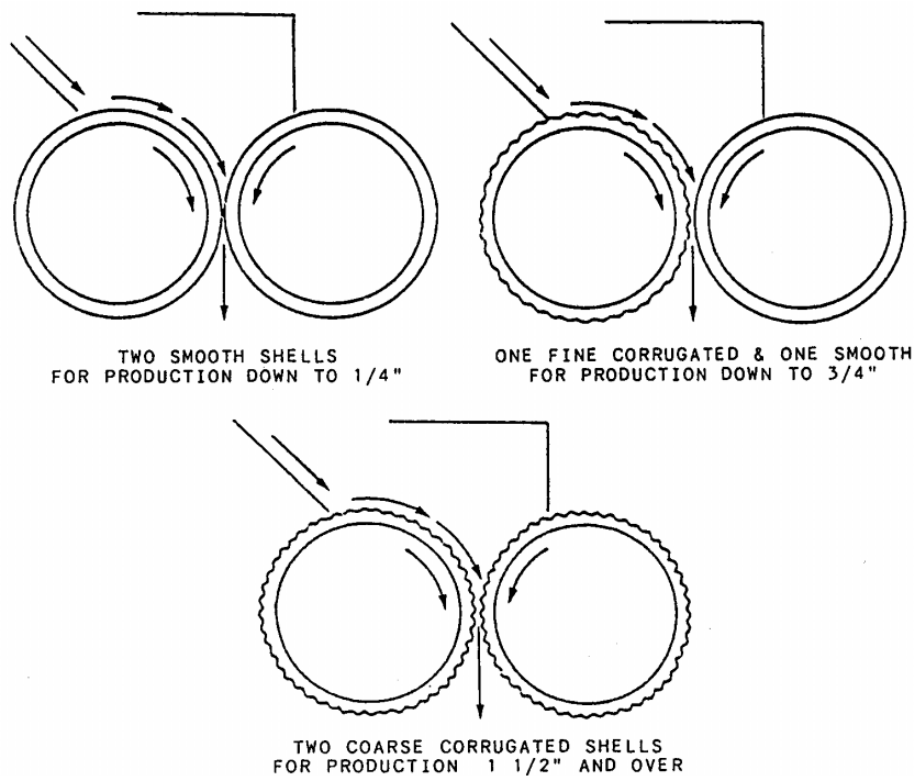

Figure 6-7.—Shell combinations for dual roll crushers.

excessive shock loading and may result in serious damage to the crusher.

All *hydrocone crushers* are supplied with a feed hopper with an adjustable feed spout that is adjustable both vertically and horizontally. Horizontal adjustment of the spout is accomplished by moving the adjustable feed spout frame on the feed hopper. Slotted holes in the upper flange of the feed hopper, and in the feed spout frame, allow the feed spout to be moved horizontally in order to position it properly over the feeder plate or spider cap. The feed spout can be positioned vertically by using studs and adjusting nuts to fasten the spout to the frame. The vertical position of the spout controls the amount of feed going into the *hydrocone crusher*.

Adjustable feed spout frame construction allows the mounting of a suitable feedbox. Normally, it is better to have the incoming feed hit the side of the feedbox, after which it falls vertically through the feed spout. This is the most effective way of obtaining proper feed to the *hydrocone crusher* (fig. 6-8).

The discharge arrangement setup must allow the material to discharge freely without backing up underneath the crusher. Material backing up below and into the *hydrocone crusher* can result in serious damage to the machine.

A straight-down discharge is commonly used with *hydrocone crushers*. With this arrangement, crushed material falls into a stone box below the crusher.

Material passes through a hole in the stone box floor onto a conveyer belt that carries it away. This discharge arrangement helps prevent buildup of sticky materials beneath the crusher.

The crushing chamber is annular (ring shaped). Rock fed into the top falls between the cone and the mantle and is crushed as the opening narrows with the movement of the cone. When the opening widens again, the pieces fall farther, to be crushed again as the cone gyrates. The crushing action is similar to that of a jaw crusher, except the squeeze comes from the side rather than from the bottom and the curve of the jaws.

The cone speed and the distance of travel must be carefully synchronized. A wide space allows pieces to fall more freely than a narrow one when the cone is moving slowly; however, it allows pieces to fall too far before the next impact. On the other hand, where the space is narrow and the cone is moving rapidly, the pieces cannot fall far enough and this causes production to be low for the amount of power being used.

CAUTION

DO NOT operate the *cone crusher* at a smaller setting than that for which it was designed. Operation at too small a discharge

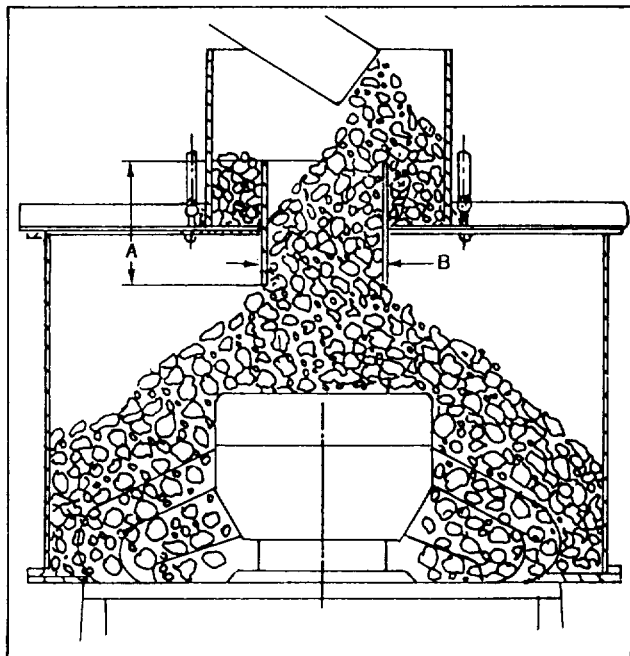

RECOMMENDED FEED ARRANGEMENT

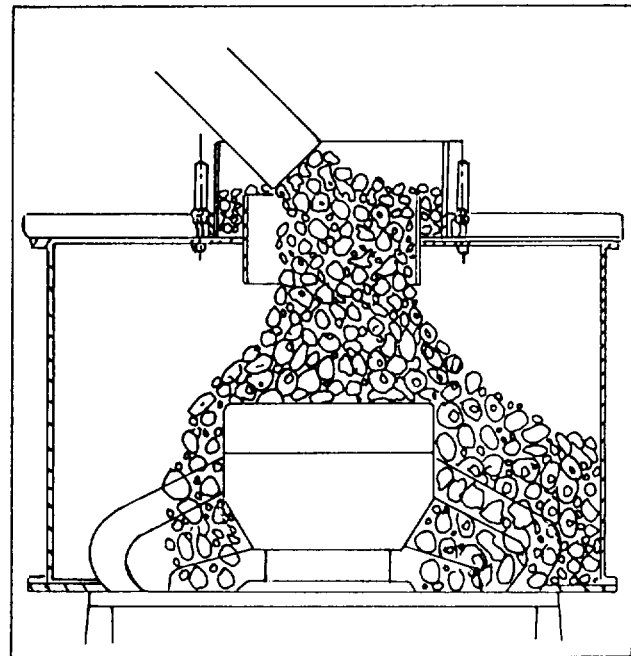

INCORRECT FEED ARRANGEMENT

Figure 6-8. Recommended cone crusher feed arrangement.

setting may result in packing in the crusher chamber, high loads and stresses, and possible damage to major components.

After passing the *dual roll crusher*, the material is recirculated to the top screen by means of a return conveyer and a revolving elevator wheel. The material from the *hydrocone crusher* is recirculated to the top screen by means of a return conveyer and a crossover chute. Any material still too large to pass the top screen is routed through the *roll crusher* or *hydrocone crusher* again. This is known as a “closed circuit” crushing system. It is obvious that the product setting on the *roll crusher* or *hydrocone crusher* should be set at or slightly less than the opening size of the top screen.

The material retained on the bottom screen is the product that is routed through a chute to a conveyer and then delivered to the product stockpile. Material too small to meet product specifications is screened out by the bottom screen and delivered to a by-product stockpile.

The secondary unit includes a bar type of scalping screen that can be inserted into the top rim of the sloping hopper. When inserted, this screen causes any oversized material to be scalped and rolled off of the screen and to the rear of the machine.

The same factors discussed for the jaw crusher also affect the production of the roll crusher. By comparison, *dual roll crushers* have a limited “stage of reduction” capability. “*Stage of reduction*” is the difference,

expressed in inches or centimeters, between the maximum input and maximum output size of material due to a single crushing action. A stage of reduction of 3 inches (7.6 cm) indicates a 3-inch (7.6-cm) reduction in maximum particle size. This reduction capability is a function of the diameter of the rolls and of the nature of the roll shell surface; therefore, every different size and combination of roll shells has a somewhat different stage of reduction capacity. For this reason the maximum size of material to be fed to a *dual roll crusher* is critical.

The maximum allowable feed size is the sum of the stage of reduction capability and the product setting. If the maximum feed size is exceeded, unsatisfactory results likely to occur are as follows:

1. Retarded production
2. Excessive roll shell wear
3. Excessive long-and-flat particles

These units also have a wide range of production capability. The actual rate of production in tons per hour is usually determined by the screening capacity of the screens. In some cases, the rate may be limited by the capacity of the *dual roll crusher* or *hydrocone crusher*.

Screens

Crushed rock particles are separated into two or more particle size ranges by the use of screens (fig. 6-9). Screens are also used to scalp off oversized rock and to

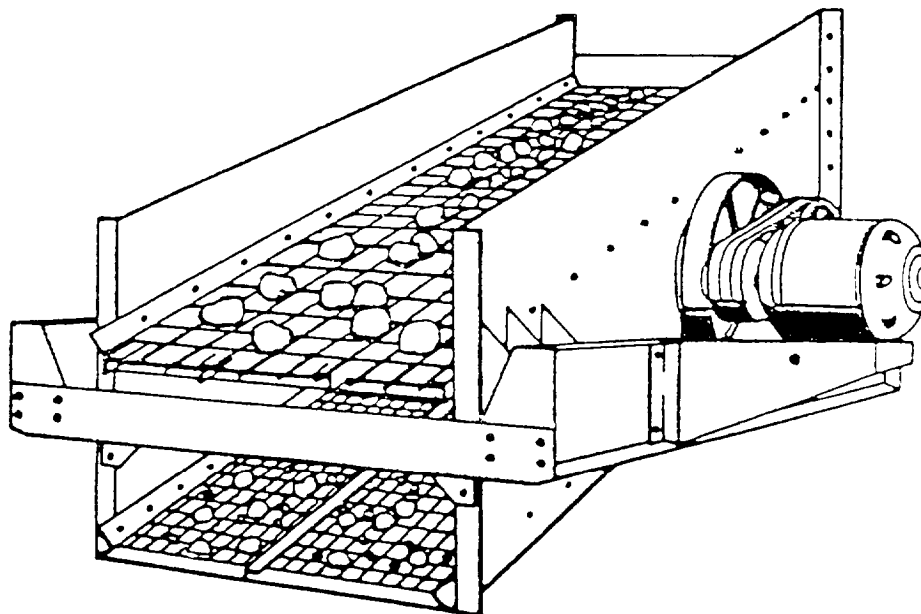

Figure 6-9.-Vibrating screen box.

screen out fines. This enables you to direct certain selected material to receive special or additional processing. Certain material may also be directed to bypass processing that is not required.

Screens consist of two, three, or four layers or decks of open-mesh screen wire cloth, mounted one above the other in a rectangular metal box. The screen surfaces are vibrated to aid sorting. Material is fed at one end and is separated into size ranges as it passes over the screening surface. The screening process is based upon the fact that particle sizes smaller than the screen cloth opening size passes through the screen and oversized particles are retained.

Stratification of the feed material must occur rapidly as the material is passed over the screen surface to obtain good efficiency and high capacity. This ensures the smaller particles can move quickly to the bottom and fall through the screen openings, and the larger oversized particles are carried to the top of the feed stream where they are retained and directed off the end of the screen. The desired performance of specific screens is obtained by varying the *degree of inclination, frequency and amplitude of stroke, and the direction of throw.* Screens may be horizontal or inclined up to about 20 degrees and vibrate at 850 to 1,250 strokes per minute, depending upon the particular application.

CAPACITY.— Capacity is the rate in tons per hour at which a screen produces (passes) the material desired. The capacity of a screen is the rate at which it separates desired material from the feed.

FEEDING MATERIALS TO SCREEN.— Care must be taken to spread the flow of material evenly across the full width of the screen. *The thickness of the bed of feed material should be approximately four times the screen opening size.* If this is exceeded, the screen becomes overloaded and the vibrations are dampened. This results in the finer particles being unable to find their way to the screen wire opening. When an insufficient amount of material is fed, the total capacity of the screen is not used.

VARIABLE FACTORS.— Numerous factors can affect the performance of screens. Some examples of these are as follows: shapes, weight, and gradation of particles; degree of inclination and vibration; type of wire screen cloth; position of the screen within the deck; and wet screening (washing).

Screen Selection

Once the gradation of material has been determined, screens must be selected that can segregate the materials into appropriate sizes. The number of screens to be selected is dependent upon the number of size ranges into which the material must be segregated and the type of equipment available for screening. Table 6-1 gives the screen sizes of vibrating screens used to produce specific sizes of aggregate.

Table 61.-Vibrating Screen Selection Chart

<i>Product size</i>	<i>Required screen size</i>
No. 8	No. 4
No. 6	3/16"
No. 4	1/4"
1/4"	5/16"
5/16"	3/8"
3/8"	7/16"
7/16"	1/2"
1/2"	5/8"
11/16"	3/4"
3/4"	7/8"
7/8"	1"
1"	1-1/8"
1-1/8"	1-1/4"
1-1/4"	1-3/8"
1-3/8"	1-1/2"
1-1/2"	1-3/4"
1-3/4"	2"
2"	2-1/4"
2-1/4"	2-1/2"
2-1/2"	2-3/4"
2-3/4"	3"
3"	3-1/2"
3-1/2"	4"

The selection of screen sizes depends upon the size of the product desired. The maximum and minimum sizes of the product are expressed in the specifications. Consider the following specifications:

<u>Size</u>	<u>Percent Passing</u>
1 inch	100 percent
3/4 inch	90 to 100 percent
1/2 inch	20 to 50 percent
3/8 inch	0 to 15 percent
No. 4	0 to 5 percent

By this specification, the largest size aggregate that is acceptable is 1 inch. Since 100 percent must pass through the screen for 1-inch aggregate, 0 percent can be larger than 1 inch. Although the specification says that the lot is acceptable with up to 5 percent of the total product passing through a No. 4 sieve, it is saying that the No. 4 aggregate is the smallest size desired.

Based on these specifications, the plant should be calibrated to produce a product between 3/4 and 3/8 inches. The reasoning behind calibrating the plant to produce a 3/4-inch to 3/8-inch aggregate rather than a 1-inch to No. 4-size aggregate is because somewhat oversized particles can pass a given screen opening size when oriented diagonally.

By calibrating the plant to produce a top size of 3/4-inch aggregate, you can provide a safety margin of 10 percent in the event the product stockpile may contain aggregate over 3/4 inch, but less than 1 inch. The same reasoning holds true on the minimum product size. Calibrate the plant to produce 3/8-inch aggregate as the minimum size, thereby creating a 15-percent leeway for particles in the stockpile being less than 3/8 inch. Therefore, *you should choose the next smaller size screen than the given maximum specification size for the upper size calibration. Similarly, you should choose the next larger size screen than the given minimum specification size for the lower size calibration.*

Remember: It is necessary to select screens with openings slightly larger than the size products desired. This is due to screen inefficiency caused by the tangle of inclination, throw, and angular particle shapes.

Table 6-1 is used for the selection of screens and the relationship between product size and screen size. For example:

If your plant has a two-deck vibrating screen, you should select the following screens:

<u>Product Size Desired</u>	<u>Screen Size Selected</u>
Top 3/4 inch	7/8 inch
Bottom 3/8 inch	7/16 inch

The relationship between aggregate size and screen size is important. The required screen sizes are slightly larger than the product sizes. If a 7/8-inch screen is not available, a 3/4-inch screen should be selected to be put in the unit. If a 7/16-inch screen is not available, a 3/8-inch screen should be used.

Conveyers

Conveyers (fig. 6-10) are used to move material being processed from one component to another and to convey the finished product into bins, trucks, or stockpiles. Rubber belt conveyers are of the fixed or portable type. Fixed conveyers are attached to an area component of the crusher unit. They are similar in design and work on the same principle as do portable conveyers.

Before operating conveyers, check to see that belts are aligned and do not rub on the frame or other parts of the plant. As each conveyer is operated, check to see if the belts are running true. If the conveyer belt is running to one side on the head or tail pulley, then tighten the end adjustments on that side until the belt is running in the center of the pulleys. On new assembled conveyers, this procedure must be performed quite often during the first few days until the belt is trained. Even after the head and tail pulleys are set and the belts are running centrally over them, a conveyer belt may ride to one side and off the end of the troughing rolls. Should this occur, loosen three or four troughing roll assemblies and slide the ends upward about one-fourth inch on the side to which the belt is climbing. This action forces the belt toward the center of the troughing rolls. The (roughing roll frames have slotted holes to allow for this adjustment. The return roll frames have slotted holes for adjustments and may be adjusted in the same manner as the (roughing rolls.

Make sure all troughing and return rolls are rotating. Rolls can be worn through and belts damaged if the rolls become jammed. The belts should be checked frequently to ensure the fasteners are holding and the belts are not slashed or torn. Operating a conveyer with defective fasteners or belts is dangerous to personnel operating the plant and could also cause damage to other equipment.

All conveyers are provided with wipers located near the tail pulley on the return run of the belt. Keep the

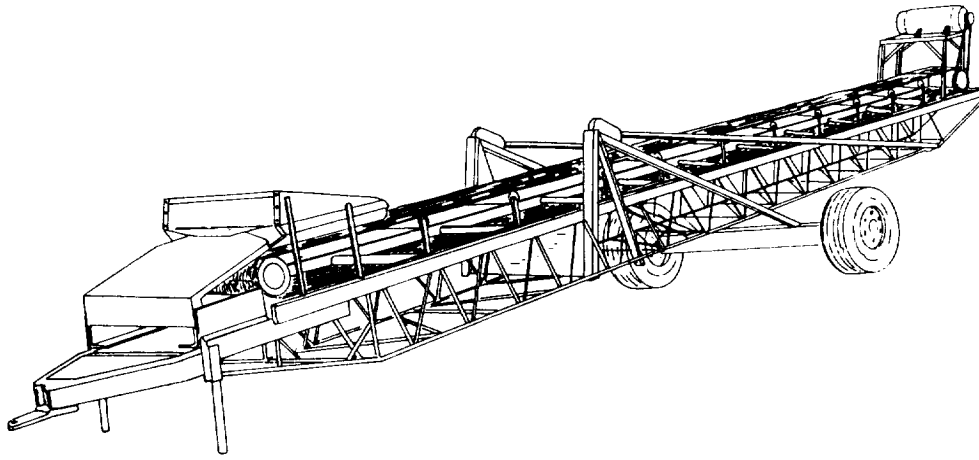

Figure 6-10.-Conveyer.

rubber stripping of the wipers adjusted to just make contact with the face of the belt. This adjustment removes rocks from the belt, thus preventing rocks from entering between the pulley face and inside face of the belt.

Three factors affect the efficiency of conveyer operation. These factors are as follows: speed, loading, and incline.

1. Speed. Most conveyers operate at a speed of approximately 300 feet per minute and have a capacity of approximately 300 tons of material per hour. A reduction in speed obviously reduces the conveyer capacity, and an increase in speed theoretically increases the capacity. An increase in conveyer speed may also increase wear on the conveyer belt due to increased slippage of the material at the loading point. An increase in speed also increases the *throw* of the material at the discharge end of the conveyer. In some cases, it may be necessary to fit the end of the conveyer with a box or *bangboard* so the material from the belt falls properly.

2. Loading. Proper loading of a belt conveyer is mandatory for efficient operation. This includes placing the load in a position centered on the conveyer belt. A *good practice is to load a conveyer in such a manner that allows the material to strike the belt in the direction of travel.* When material is to be delivered from a spout or belt to another belt from one side, a transfer box or *bangboard* should be provided to facilitate proper delivery on the belt. Loading a conveyer belt on one side causes it to run to the opposite side of the support rollers which results in excessive belt wear.

3. Incline. Portable conveyers can be adjusted to operate at the various inclines required to meet job conditions. The maximum incline is determined by the

material carried on the conveyer and varies from 12 degrees for washed gravel to 20 degrees for loose earth. When the maximum angle is exceeded, slippage may occur.

WASH PLANT

In many types of construction operations, it is not necessary to have washed clean aggregates in the finished product; however, some types of operations require clean aggregates free of objectionable material. The wash and screen plant (fig. 6-11) consists of a scrubber, a vibrating screen, and a screw (sand) dehydrator (fig. 6-12). In operation the raw material is fed into a scrubber designed to break loose all deleterious material. The scrubbed aggregate and wash water are cast upon a triple deck vibrating screen for size separation. The materials retained on the decks of the screen are sent by individual chutes to their respective conveyers for further disposition. The wash water and sand are carried through the third deck into the well of the sand dehydrator, where the undesirable products are removed from the sand by the abrasive washing action of the spiral conveyer and carried out into a flume by means of the overflow water. The clean sand is carried up and out of the water and discharged into a stockpiling conveyer.

The capacity of the washing and screening plant is based on the percent of sand in the deposit; for example, each single screw washer can handle a certain amount of material. The screen is also a factor to consider when figuring the capacity of this plant. It is necessary to have enough screening area to handle each gradation of material desired.

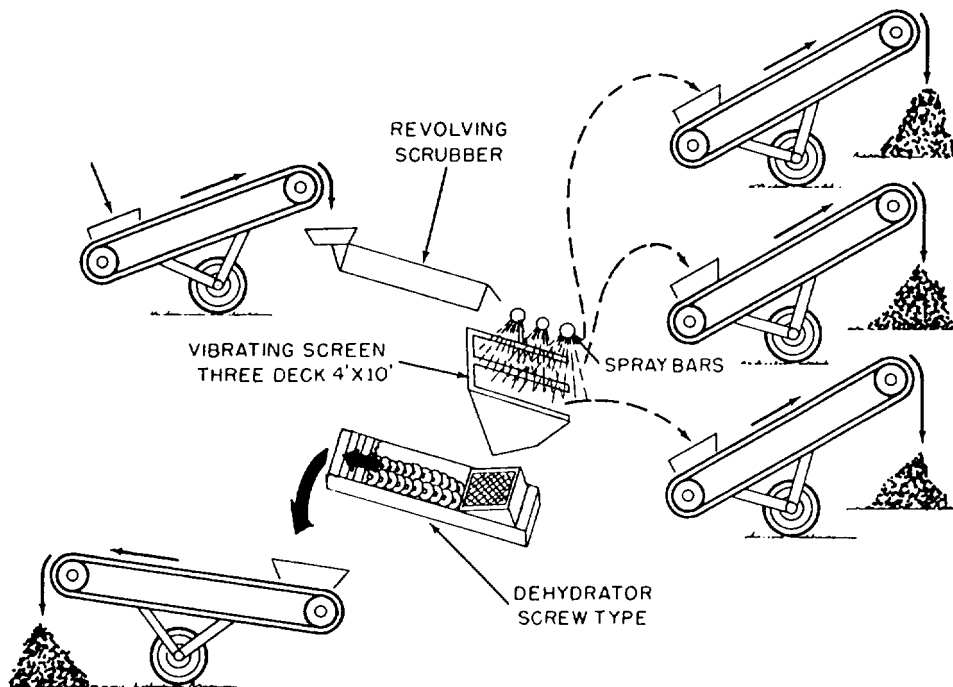

Figure 6-11.—Wash and screen plant.

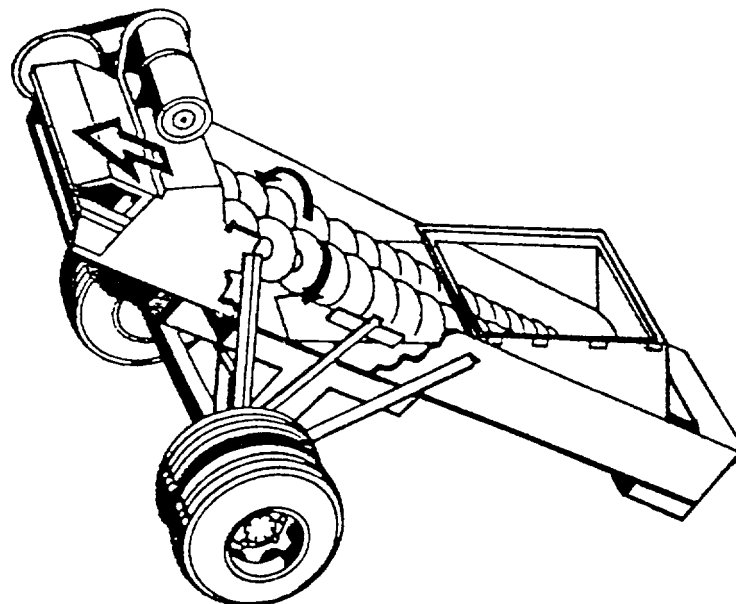

Figure 6-12.—Sand dehydrator.

PLANT LAYOUT

Once the plant is in operation, there is seldom time available to stop operations to remodel; therefore, the layout and erection of the crusher unit should be given adequate time to ensure an efficient facility is built.

Equipment Configuration

Special attention should be given to creating a logical flow of material from the point where trucks enter the plant with raw material to the point where trucks depart from the crusher with crushed aggregate products. You should evaluate the physical environmental requirements of each piece of equipment, such as foundation requirements, water requirements, and power requirements, to ensure they are included during the construction stage.

Drainage

Adequate drainage channels should be constructed during the initial earthworking stage of construction and constantly improved as the plant is built. This is significant because most of the rock crushing plants have electrical components inherent to their operation.

Prevailing Winds

Equipment should be oriented in such a manner that prevailing winds carry the rock dust generated by the crusher away from the facility. Support equipment, such as generators and water pumps, and permanent facilities, such as latrines, offices, and maintenance shops, should be located out of the path of winds carrying the rock dust.

DO NOT FORGET THE DEPARTMENT OF ENVIRONMENTAL QUALITY (DEQ) REQUIREMENTS FOR DUST CONTROL. The DEQ works for the *Environmental Protection Agency (EPA)*. The EPA has established standards for controlling the amount of rock dust that can be admitted into the air.

The *COMSECOND/COMTHIRDNCB Equipment Offices* work closely with the DEQ to ensure the plants in the NCF abide by the rules of the DEQ. Sprinkler systems have been installed on rock crushers in the NCF to control the rock dust produced from crushing operations to meet the requirements of one rule. As the crusher supervisor, you are responsible to make sure these systems remain operational.

Organization of Space

The crusher design should include adequate space around the equipment. This space is required to provide access areas for maintenance personnel to perform repairs, space to move cranes in and out to lift out and replace or rotate worn jaw plates and roll shells, space for the fuel truck to refuel the equipment, and space to remove and replace components of the crusher unit.

Material Handling and Storage

The plant should include adequate material-handling devices to expedite the flow of material through the plant and eliminate double handling of the material.

A headwall ramp should be constructed to allow haul units or loaders to back up to or approach the apron feeder of the primary unit and discharge their loads. If a problem with oversized rock is anticipated, you should have a prescreening grizzly built in the quarry or over the apron feeder to remove the oversized rock.

When possible, store quality product size aggregate in bins, rather than in open stockpiles. This is most important when the aggregate is crushed to specifications sizes or has been washed. Open stockpiling of aggregate can be contaminated by windblown sand, fines, and trash.

When bins are not available for aggregate storage, headwalls should be constructed for stockpiles to ensure separation of different sizes of aggregate being processed. The area separating headwalls should be large enough to stockpile a large supply of aggregate and have adequate space on the front side for loading vehicles without causing congested traffic areas.

Aggregate stockpiles are loaded by loaders or clamshells. These machines are most efficient for loading vehicles with clean aggregate off the top of stockpiles. The aggregates at the bottom of stockpiles become embedded in the ground and tend to become contaminated. This layer is lost for use.

Stockpiling

Stockpiling is most efficiently accomplished on hard, flat, clear areas. The location of the stockpiles should be convenient to the quarry, the crusher, and the hauling unit. When available space is large compared with the bulk of material to be stored, trucks may dump piles as closely as possible to each other.

When packing by trucks does not cause damage to the material, a pile can be smoothed off with a dozer, and one or more additional layers can be added. Factors limiting the maximum height are the slope in from the edges and the gradual grade for the truck ramp. Figure 6-13 illustrates the building of a stockpile by backing trucks upon the ramp and building it up in layers. Ramp grade should not be so steep as to strain the truck or to prevent them from dumping cleanly.

Figure 6-14 illustrates the building of a stockpile by use of a spiral ramp. This is started as a narrow, backup pile that is spread on the outside far enough to protect the ramp from caving in and well past the center on the inside. The ramp, steadily rising, is turned and comes back on the far side, parallel with the first section, but above it. Material is still dumped far enough to the outside and inside to protect the ramp.

When material is too soft or too loose to support trucks, the ramps may be strengthened by the use of wire mats, or small quantities of screening, soil, or other binders if their use will not spoil the value of the stockpile.

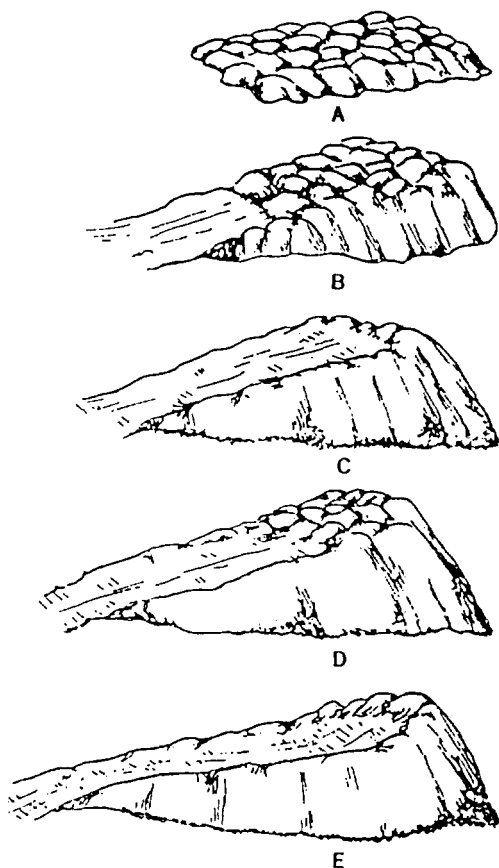

Figure 6-13.-Ramp stockpile.

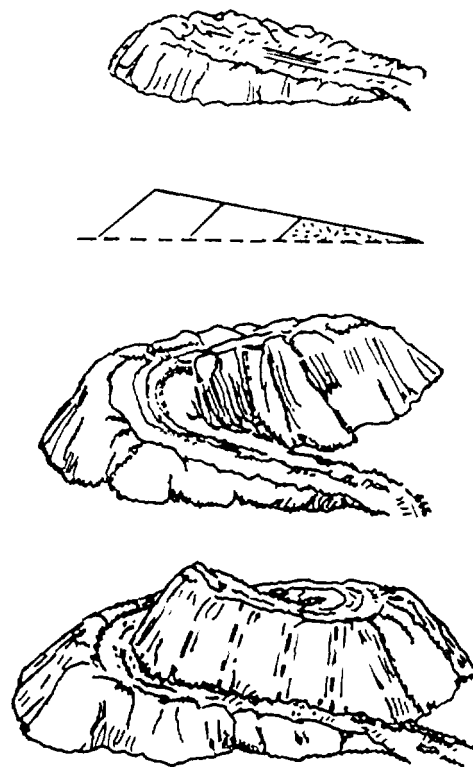

Figure 6-14.-Spiral ramp stockpile.

Trucks may be kept off a stockpile, either for safety measures or to avoid packing, by dumping on level ground and piling by dozer or loader. The loader is more efficient because it can combine lift with push for higher, steeper piles with shorter moves and less power consumption heaping stockpiles rapidly. The dozer is entirely flexible in placing or varying the size and shape of a stockpile and can be used for a variety of other work; however, it must move its entire weight up the pile with each load, and the constantly working tracks on the dozer may be subjected to severe wear in sand or other abrasive materials. Also, the tracks may pack or crush soft materials that drastically reduces their value.

Choice of tracks or wheels depends on the availability of equipment and the type of material. Wheels provide more compaction and cause less breakage into fines. They wear less in sand or gravel as long as the operators avoid spinning the tires during loading operations; however, wheels become ineffective under slippery conditions.

Loaders of either type can be used to reclaim the pile, loading the material into trucks or carrying it to hoppers or to the area of use. Tires have an advantage in both speed and economy for carries greater than 50 feet.

Road Networks

During the plant erection stage, plans should be made for the layout of roads. Well-planned roads are needed to prevent congestion, decrease the time haul units are in the plant, and for safety. Road networks are needed for the following:

1. Haul units bringing rock from the quarry
2. Trucks hauling the product aggregate to construction sites
3. Service vehicles, such as crew, fuel, and maintenance vehicles

If possible, plant roads should be one way and be wide enough for the largest haul unit expected. They should be designed to support heavy loads.

Plant roads must be maintained constantly. In dry areas where there is little rainfall, a water truck is required to wet down the roads to control the dust. In wet areas crushed rock should be used on the roads to keep haul units from sliding off into ditches. A maximum speed limit should be posted for vehicular traffic within the crusher area and on the haul roads.

PLANT ERECTION

The importance of proper site preparation and proper stationing of the plant cannot be overemphasized. Your site for stationing the plant should be flat, level, and well compacted. Crushing and screening plants may be operated for short periods of time from the wheelbase. But it is advantageous on longer and more deliberate jobs, from a maintenance standpoint, not to operate the plant until it has been blocked and leveled with the tires clear of the ground. You should include the following steps in the operational start-up phase:

Operating instructions. All appropriate technical manuals must be reviewed and studied before the beginning of plant operations.

Training. You should train all personnel assigned to operate and maintain the plant. During this training period the importance of site preparation, setup, maintenance, and safety should be emphasized. You should keep the proper tools, materials, and manuals at the site. A high rate of aggregate production should not be expected until personnel become familiar with the equipment.

Tools. The tools used in maintenance and assembly of the plant are included in the mechanic's tool kit which

is part of the NCF TOA. Basic issue items that are incorporated with each plant are also available.

Leveling. The plant should be leveled before initial operation and should be frequently checked while in operation. Leveling should be done on the frame for longitudinal leveling. A rigid, straight plank should be used across the unit frame rails for transverse leveling. The leveling should be checked at several points throughout the unit.

Blocking. Blocks should be installed under each side of the tandem axles and under the dolly axle or the fifth wheel plate to raise the tires or landing gear clear of the ground. Place blocking or cribbing parallel to the longitudinal center line of the unit.

Hydraulic jacks. Jacks should be on each side of the unit opposite each other and under the unit frame members. Raise and lower the jacks in equal increments to prevent bending of the frame.

Screw type of stabilizing jacks. Tighten the screw type of stabilizing jacks to *maximum* torque after the crusher has been blocked and leveled.

Nuts and bolts. Ensure *all bolts are tight by torquing the nuts, not the bolt heads*. Additionally, retorquing should be continued throughout the operation of the plant. This should be performed at critical locations and during the initial operation to assure proper seating and prevent parts from loosening and getting out of adjustment. Any adjustments required, such as movement of trunnion wheels on the trunnion shaft, should be made during the first hours of operation.

Jaw plates and roll shells are held in place by wedges which are secured by keeper bolts. The wedges must be driven *home* with a sledge hammer while constantly applying torque with the wrench to achieve proper tightening.

Visual inspection. To prevent damage and eventual breakage, you should visually inspect the plant constantly to detect any misadjustment or loss of adjustment. Visual inspections should be made from ground level, from the platform, and from walkways. All adjustments should be checked with the components operating while empty and rechecked while loaded with aggregate.

75-tph Plant

The 75-ton-per-hour plant is used in any of four basic setups, depending upon the raw material available

and the nature of end products required for construction projects. The four basic setups are as follows:

1. The jaw crusher is used alone to work with quarry rock. Large quantities of material are ordinarily needed for base course, roads, and airfields; the fine particles are desired for binder. This means all of the crushed material is used together with no screening necessary.

2. The primary and secondary units are used in conjunction with each other to produce graded aggregate from quarry rock. The material is reduced in successive stages and screened to separate material into size ranges required to meet specifications.

3. The primary and secondary units are used together to produce graded aggregate from gravel deposits which are too large in size to be handled by the secondary unit alone.

4. The secondary unit is used alone when the bulk of material in a gravel deposit does not exceed 3 inches in diameter. In this case, a positive means is provided to limit the size of material fed to the unit.

Rarely are two aggregate production operations exactly the same. Each project must be analyzed on the basis of its own particular conditions and requirements. The 75-tph plant equipment is sufficiently flexible to meet all aggregate requirements of construction battalions.

Maintaining Quarry Equipment

Because of the working conditions around a crushing operation, the entire crew must be totally

familiar with the manufacturer's requirements and any special conditions that may exist. This ensures proper maintenance and the safe and productive operation of the crusher equipment.

The entire quarry and rock production operation depends on proper and adequate maintenance of equipment. A regulated program of maintenance, including step-by-step procedures, is recommended for each piece of equipment.

In contrast to other types of construction equipment, procurement of repair parts and new units for crushing and screening equipment requires a much greater lead time. Without proper parts and units, production either slows down or stops altogether.

As the supervisor in charge of crushing and screening operations, you must ensure operator maintenance procedures are performed by the operators and maintenance mechanics to ensure continuous operation of the equipment.

WARNING

Be sure the main power sources remains "OFF" and are properly "red-tagged" while personnel are working on electrical equipment.

Frequent inspections should be made during operations to ensure that the equipment is not being abused, that the units are level and cribbed, that calibrations are correct, and that proper shutdown procedures are followed.

CONCRETE BATCH PLANT SUPERVISOR

Concrete is a mixture of cement and water that binds aggregates, such as sand and gravel or crushed stone, into a rocklike mass and when properly constructed, it is very rigid and has a long life. This is a result of the chemical reaction between the cement and water called *hydration*. The Naval Construction Force (NCF) has various equipment used to provide concrete for construction purposes. This equipment ranges from the 11S mixer, transit mixer, mobile concrete mixer plant (crete mobile), and the concrete batch plant.

Most concrete production operations are supported by an experienced Builder (BU). However, EOs must understand the basic principles of concrete mix design and the procedures performed to produce quality concrete.

CONCRETE BATCH PLANT SUPERVISOR RESPONSIBILITIES

When assigned as the supervisor of a concrete batch plant in the NCF, you supervise the production and transport of concrete products used to construct sidewalks, roads, footers, foundations, walls, roofs, runways, rapid runway repairs, and so forth.

PORTLAND CEMENT

Portland cement is usually made of materials, such as limestone or marl and shale or clay. The raw materials are crushed, pulverized, and mixed in proper proportions for the correct chemical composition. Then, the raw material is fed into a rotary kiln and is calcined (burned) at a temperature of approximately 2700°F. This process transforms the material into a clinker. The clinker is cooled and pulverized so fine that nearly all of the powder can pass through a No. 200 mesh sieve.

Types of Cement

When powdered Portland cement and water are combined, hydration occurs. The amount of water per unit weight of cement is called the water-cement ratio normally given in terms of pounds of water per pounds of cement. Concrete with a low water cement ratio gains

more strength than cement with a higher water cement ratio.

There are many types of cement, but only the most common types are listed here:

Type I (normal portland cement) is the most widely used cement for pavements, sidewalks, buildings, bridges, masonry units, and soil-cement mixtures. In general, it is used when the concrete will not be subjected to special sulfate hazards or where the heat generated by the hydration of the cement does not cause an objectionable rise in temperature.

Type II (modified portland cement) has a lower heat of hydration than Type I. This lower heat gives this cement an improved resistance to sulfate attack. Type II cement is used in large structures where cement of moderate heat of hydration tends to minimize a rise in temperature. Examples are as follows: large piers, heavy abutments, heavy retaining walls, and when the concrete is placed in warm weather. Type 11 cement is also used in drainage structures where the sulfate concentrations are higher than normal.

Type III (high-early-strength portland cement) is used when superior strength is required in a short time. It is used in cold-weather construction to reduce the period of protection against low temperatures. Type III is also used when forms have to be removed immediately to allow the concrete to be put in service as quickly as possible. Type III cement requires less protection time from freezing and attains normal 3-day strength in 1 day. The volume of heat during hydration is also accelerated. Normally, this cement is not used in large-scale construction operations because it is very expensive.

Storage of Cement

Portland cement is a moisture-sensitive material that must be protected from damp air or moisture. Cement not protected when in storage sets more slowly because hydration has already begun; therefore, it has less strength than portland cement that is kept dry.

Most types of portland cement are shipped in bulk by rail, truck, or barge. Pneumatic loading and unloading of the transport vehicles is the usual method

used to handle bulk cement. Bulk cement is measured in tons (2,000 lb) and smaller quantities are bagged in cloth or paper sacks, each containing 94 pounds of cement. A 94-pound sack of cement is equal to 1 cubic foot by loose volume.

Cement bags should not be stored on damp floors, but should rest on pallets. The bags should be stacked against each other to prevent circulation of air between them, but not stacked against outside walls. If the stacks of cement are to be stored undisturbed for long periods, they should be covered with tarpaulins.

Cement bags that have been stacked in storage for long periods sometimes acquire a hardness called *WAREHOUSEPACK*. This can usually be loosened by rolling the sack around. Cement that has lumps or is not free flowing should not be used.

AGGREGATE

The aggregates used in concrete must be strong, durable, and chemically inert and generally occupy 60 to 75 percent of the concrete mix in volume (70 to 85 percent by weight). Natural aggregate deposits are excavated from pits, rivers, lakes, or seabeds. These natural deposits consist of gravel and sand that can be readily used in concrete after minimal processing. Crushed aggregates are produced by crushing quarry rock, boulders, cobbles, or large-size gravel. Crushed aggregates are usually washed and graded before being used in concrete. The most commonly used aggregates are sand and gravel and when combined with cement produce a strong, durable mass that is practically without voids.

The coarse aggregates used in a mix usually consist of gravel or crushed stone up to 1 1/2 inches in size. Course aggregates are primarily used as filler. These aggregates can pass through a 3-inch sieve and are retained on a No. 4 sieve. In massive structures like dams, the coarse aggregates may include natural stones or rocks, ranging up to 6 inches or more in size.

Fine aggregates are those materials that can pass through a No. 4 sieve but are retained on a No. 100 sieve. The fine aggregates and sand in concrete are used to fill the voids between the large aggregates. Care should be taken to prevent dirt and other debris from getting mixed into the sand. The foreign material affects the bonding quality of the sand.

The gradation of the aggregate is a major factor in the workability, water requirements, and strength of concrete. Fine and coarse aggregates are usually sieved

separately—the fine aggregates on sieves with openings 1/4 inch or smaller and the coarse aggregate on sieves with square openings from about 1/4 inch and larger. The fine sieves are numbered—the larger the number, the smaller the sieve opening; for instance, the No. 100 sieve has 100 openings per inch, and the No. 4 sieve has 4 openings per inch.

The grading of both coarse and fine aggregate and the relative proportions of each in the mix can greatly affect the properties of the fresh concrete. Concrete made with coarse sand or not enough sand is hard to pump and will be harsh and difficult to trowel. Also, aggregates can segregate or separate from the cement paste during placement, producing nonuniform concrete. Air-entraining will help in overcoming grading problems of this kind. Coarse aggregates should be round or subround in shape. This shape allows the cement paste to coat the particles more easily during mixing.

HANDLING AND STORAGE OF AGGREGATES

Aggregates containing particles of different sizes have a natural tendency to segregate whenever loaded, transported, or otherwise disturbed. Aggregates should always be handled and stored by a method that minimizes segregation.

Stockpiles should not be built up in cone shapes, formed by dropping successive loads at the same spot. This process causes larger aggregate particles to segregate and roll down the sides, leaving the pile with a large amount of fine aggregate at the top and a large amount of coarse aggregate at the bottom. A stockpile should be built up in layers, each made by dumping successive loads alongside each other.

If aggregate is dropped in a free fall from a clamshell, loader, or a conveyor, some of the fine material may be blown aside, causing segregation of fines on the lee side of the pile. Clamshells, loaders, and conveyors should be discharged in contact with the pile.

The bottom of an overhead charging bin should always slope at least 50 degrees towards the center outlet. If the slope is less than 50 degrees, segregation will occur as the material is discharged. When a bin is being charged, the material should be dropped from a point directly over the outlet. Material dropped in at an angle or discharged against the sides of the bin will segregate. Since a long drop causes both segregation and the breakage of aggregate particles, the length of a drop

into a bin should be kept to a minimum by keeping the bin as full as possible at all times.

WATER

The primary function of water used in a concrete mix is to start the hardening process of the concrete through hydration of the cement. A secondary function is to make the mix workable enough to satisfy the requirements of the job. However, too much water will cause a loss of strength by upsetting the water-cement ratio. It will also cause "water gain" on the surface, a condition which leaves a surface layer of weak material called LAITANCE. Also, an excessive amount of water will impair the water tightness of the concrete.

Water used in mixing concrete must be clean and free from oils, alkalis, acids, and organic materials. Most specifications recommend the mixing water be fit for drinking. This is because any water fit for drinking is usually satisfactory for use in mixing concrete. Seawater may be used for unreinforced concrete.

ADDITIVES USED IN CONCRETE

There are several additives or admixtures used to change the composition of concrete or to accelerate or retard its hardening. The three commonly used are air-entraining agents, retarders, and accelerators. Additives are not recommended if the end result can be reached more economically by altering the mix proportions.

Air-entraining portland cement is a special cement that can be used with good results for a variety of conditions. It was developed to produce concrete that has a resistance to freeze-thaw action and scaling caused by chemicals applied for severe frost and ice removal. Air-entraining agents are liquids derived from natural wood resins, animal fats, vegetable fats, or various wetting agents, such as alkali salts and water-soluble soaps. Agents are blended with the cement during manufacturing or added at the mixing site. If done at the site, the agent is added to the water used in the mix.

Manufactured air-entraining cements are indicated by the letter *A* in the type number (Types IA, IIA, IIIA, etc.). Concrete made with this cement contains billions of extremely small, entirely separated air bubbles per cubic foot of concrete. These bubbles provide space for water to expand due to freezing without damage to the concrete.

Retarders are used to slow down the rate of setting of a concrete. High temperatures of fresh concrete (85°F - 90°F and higher) are often the cause of an increased rate of hardening that makes placing and finishing difficult. One practical way to reduce the temperature of the concrete is by cooling the mixing water or the aggregates. Retarders do not decrease the initial temperature of the concrete. Retarders are sometimes used to do the following:

1. Offset the accelerating effect of hot weather on the setting of concrete
2. Delay the initial set of concrete when difficult or unusual conditions of placement occur, such as placing concrete in large piers and foundations
3. Delay the set for a special finishing process, such as an exposed aggregate surface

Some of the materials used to retard the set of a concrete mixture are lignin, borax, sugar, tartaric acid, and salt. These materials should be added to the mixing water.

CAUTION

If 20 percent by volume of retarding agent is added to the mix, the effect is reversed and it then acts as an accelerator.

Accelerators are used to accelerate the strength development of concrete at an early age. Calcium chloride is the material most commonly used in accelerating admixtures; however, in addition to accelerating strength gain, calcium chloride causes an increase in drying shrinkage, potential reinforcement corrosion, discoloration, and scaling potential. Calcium chloride should be added to the concrete mix in solution form as part of the mixing water. If added to the concrete in dry form, all of the dry particles may not be completely dissolved during mixing. Undissolved lumps in the mix can cause pop-outs of dark spots in the hardened concrete. The amount of accelerator used should not exceed 2 percent by weight of cement.

COMPUTING CONCRETE VOLUME

To compute the volume of concrete required for a concrete pad, multiply the length of the pad by its width times its depth to get cubic feet ($L \times W \times D$); for example, a concrete pad is 20 feet in length by 30 feet in width and has a depth of 3 inches. First, convert the 3 inches into feet by dividing 3 by 12 to get 0.25 foot. Next, multiply the 20-foot length by the 30-foot width

to get 600. Finally, multiply the 600 by 0.25 to determine the volume of concrete required for the pad which, in this case, is 150 cubic feet.

Concrete is ordered and produced in quantities of cubic yards. To calculate the number of cubic yards required for the pad, divide the cubic feet of the pad by 27. This is required because there is 27 cubic feet in 1 cubic yard. Therefore, the concrete pad described in the previous paragraph, which has a volume of 150 cubic feet, requires 5.56 cubic yards of concrete: 150 cubic feet divided by 27 = 5.56 cubic yards.

Concrete projects often present varying degrees of difficulty; therefore, extra concrete is required to compensate for these difficulties. Once the total number of cubic yards of concrete is computed, add a little extra, normally 10 percent, to compensate for waste. To calculate the excess needed, multiply the cubic yards by .10 (10 percent). In the above case, multiply 5.56 cubic yards by .10 to get 0.556 cubic yards. Add the 0.556 cubic yards to the 5.56 cubic yards for a total of 6.116 or 6.12 cubic yards required for the concrete pad.

BATCHING CONCRETE

Batching is the process of weighing or volumetrically measuring and introducing into a mixer the ingredients for a batch of concrete. To produce a uniform quality concrete mix, measure the ingredients accurately for each batch. Most concrete specifications require that the batching be performed by weight, rather than by volume, because of inaccuracies in measuring aggregate, especially damp aggregate. Water and liquid air-entraining admixtures can be measured accurately by either weight or volume. Batching by using weight provides greater accuracy and avoids problems created by bulking of damp sand. Volumetric batching is used for concrete mixed in a continuous mixer, and the mobile concrete mixer (crete mobile) where weighing facilities are not at hand.

Specifications generally require that materials be measured in individual batches within the following percentages of accuracy: cement 1%, aggregate 2%, water 1%, and air-entraining admixtures 3%.

Equipment within the plant should be capable of measuring quantities within these tolerances for the smallest to the largest batch of concrete produced. The accuracy of the batching equipment must be checked and adjusted when necessary.

Mixing Concrete

Concrete should be mixed until it is uniform in appearance and all the ingredients are evenly distributed. Mixers should not be loaded above their rated capacities and should be operated at approximately the speeds for which they were designed. If the blades of the mixer become worn or coated with hardened concrete, the mixing action will be less efficient. Worn blades should be replaced and the hardened concrete removed periodically, preferably after each production of concrete.

When a transit mixer (TM) (fig. 7-1) is used for mixing concrete, 70 to 100 revolutions of the drum at the rate of rotation designated by the manufacturer as *mixing speed* are usually required to produce the specified uniformity. No more than 100 revolutions at mixing speed should be used. All revolutions after 100 should be at a rate of rotation designated by the manufacturer as *agitating speed*. Agitating speed is usually about 2 to 6 revolutions per minute, and mixing speed is generally about 6 to 18 revolutions per minute. Mixing for long periods of time at high speeds, about 1 or more hours, can result in concrete strength loss, temperature rise, excessive loss of entrained air, and accelerated slump loss.

Concrete mixed in a transit mixer should be delivered and discharged within 1 1/2 hours or before the drum has revolved 300 times after the introduction of water to cement and aggregates or the cement to the aggregates. Mixers and agitators should always be operated within the limits of the volume and speed of rotation designated by the equipment manufacturer.

Overmixing Concrete

Overmixing concrete damages the quality of the concrete, tends to grind the aggregate into smaller pieces, increases the temperature of the mix, lowers the slump, decreases air entrainment, and decreases the strength of the concrete. Also, overmixing puts needless wear on the drum and blades of the transit mixer.

To select the best mixing speed for a load of concrete, estimate the travel time to the project (in minutes) and divide this into the minimum desired number of revolutions at mixing speed-70. The results will be the best drum speed; for instance, if the haul is 10 minutes, 70 divided by 10 equals 7. With this drum speed, the load will arrive on the jobsite with exactly 70 turns at mixing speed, with no overmixing of the concrete mix and no unnecessary wear on the

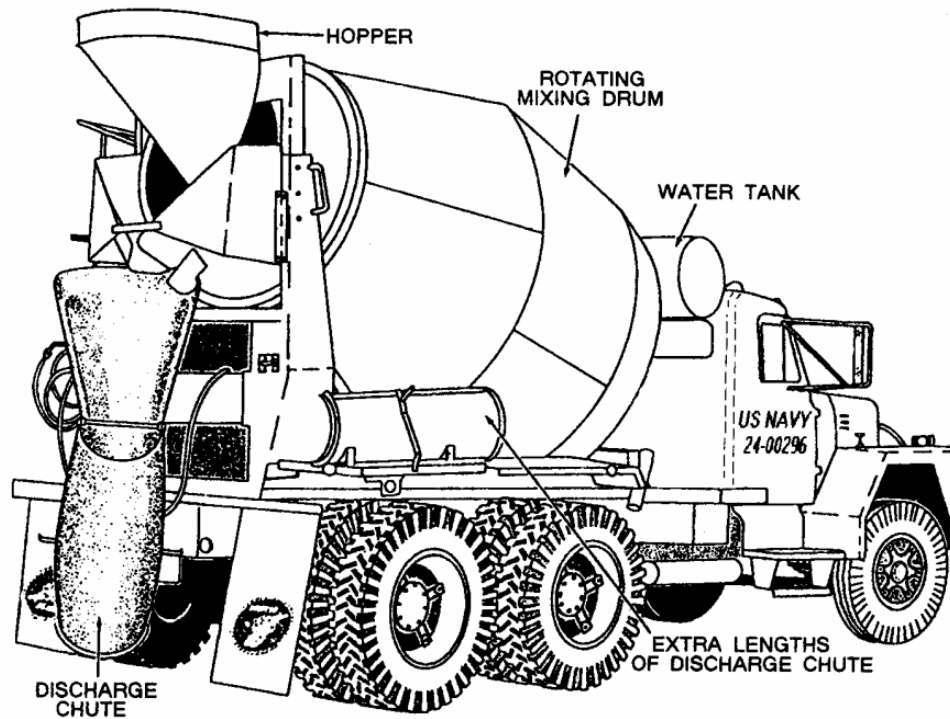

Figure 7-1.-Transit mixer.

equipment. If the concrete cannot be discharged immediately, the operator should turn the drum at the minimum agitating speed of 2 revolutions per minute. When the transit mixer arrives at the project having used the minimum amount of mixing turns, the operator is able, if necessary, to delay discharging the concrete. Delay is limited by the maximum of 300 rotations allowed.

Remixing Concrete

Concrete begins to stiffen as soon as the cement and water are mixed. However, the degree of stiffening that occurs in the first 30 minutes is not usually a problem; concrete that is kept agitated generally can be placed within 1 1/2 hours after mixing.

Fresh concrete left to agitate in the mixer drum may be used if upon remixing it becomes sufficiently plastic to be consolidated in the forms. Under careful supervision a small amount of water may be added to remix the concrete provided the following conditions are met: (1) maximum allowable water-cement ratio is not exceeded, (2) maximum allowable slump is not exceeded, (3) maximum allowable mixing and agitating time (or drum revolutions) are not exceeded, and (4) concrete is remixed for at least half the minimum required mixing time or number of revolutions.

Adding too much water to make concrete more fluid should not be allowed because this lowers the quality of the concrete. Remixed concrete can be expected to harden quickly. Subsequently, a cold joint may develop when concrete is placed next to or above the remixed concrete.

Mixer Cleaning

After the load of concrete is discharged from the mixer, the operator should wash off all excess concrete in the mixer drum and blades, the discharge chute opening, and the discharge chute before it has a chance to harden. Spraying 15 to 25 gallons of water into the drum while it is rotating will clean the inside of the drum as well as remove all grout which may have collected in the water nozzle during discharge. A washdown hose is provided on the mixer to clean areas accessible from the outside. A clean mixer produces a more satisfactory mixing and discharge of concrete.

At the plant, flush a minimum of 150 to 250 gallons of water, depending on the size of the mixer, into the drum. With the flush water in the drum, rotate the drum in the mixing direction for a few minutes, then discharge the flush water at the maximum drum rpm. Complete the cleaning of the outside of the mixer, particularly around the discharge end.

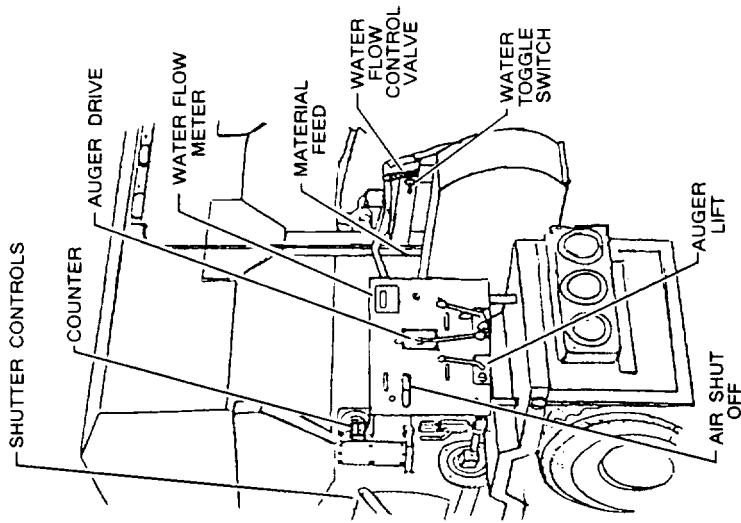
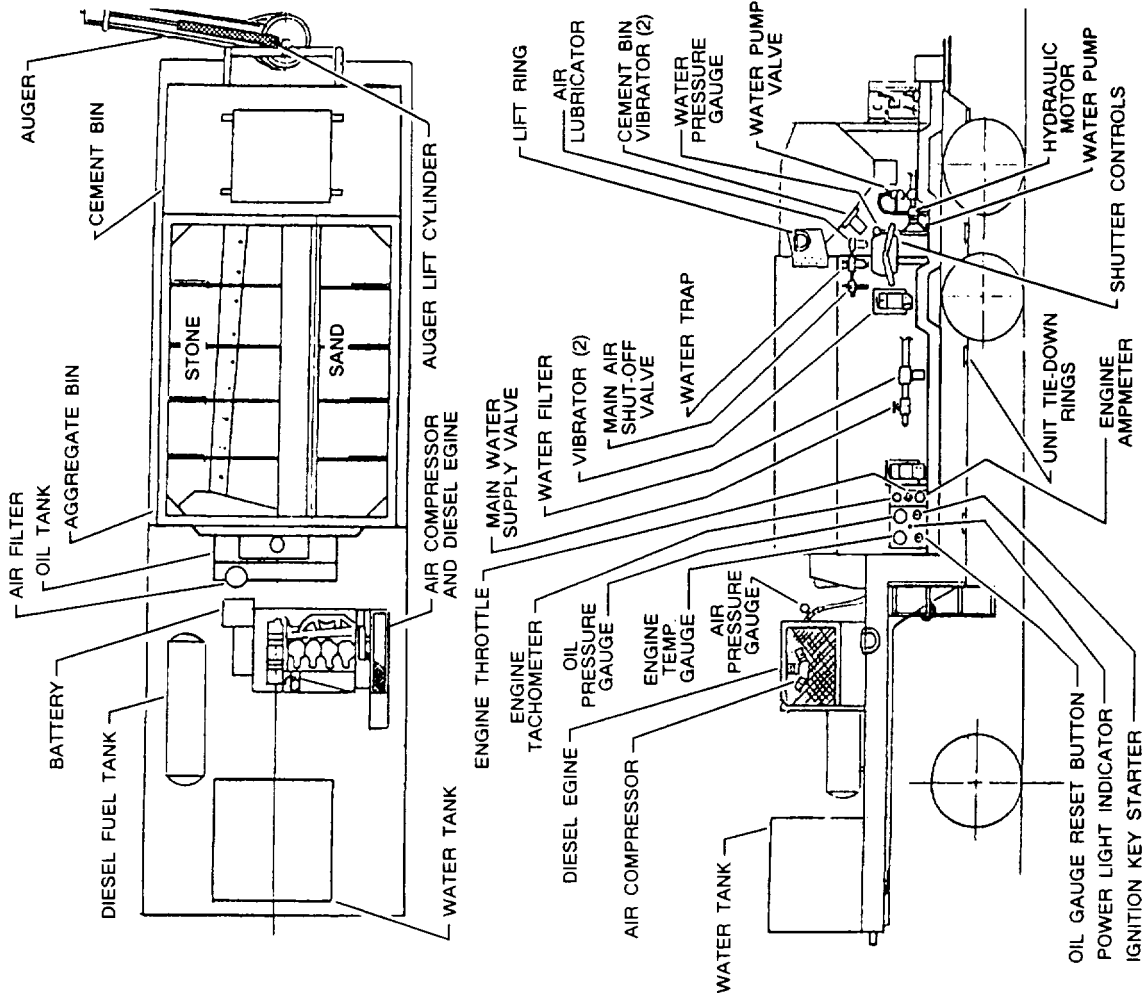

Figure 7-2.-Mobile concrete mixer plant.

MOBILE CONCRETE MIXER PLANT

The trailer-mounted mobile concrete mixer plant (fig. 7-2) carries cement, sand, and coarse aggregates in divided bins mounted on the unit. The cement is carried in a separate bin located across the rear of the unit, and the sand and aggregate are carried on each side of the unit. Water is carried in a single tank mounted in front of the aggregate bins and is pumped to the mix auger. Sand and aggregates are accurately proportioned by weight or volume and simultaneously dropped with a mixture of cement from the material feed system into the charging end of the mix auger/conveyor at the rear of the unit. At this point, a predetermined amount of water enters the mix auger. The action of this combined auger and paddle homogenizer mixes the ingredients and water rapidly, thoroughly, and continuously to produce a continuous flow of uniformed quality concrete. The material mixing action is a continuous process that can proceed until the aggregate bins are empty. On the other hand, mixing and delivery may be stopped at any time and then started again at the will of the operator. This permits production to be balanced to the demands of the placing and finishing crews and other job requirements.

Operators assigned to the "crete mobile" must thoroughly read and understand the technical manual before operating the plant.

The following are the mobile concrete mixer plant cautions and warnings:

Follow all preventive maintenance procedures.

- Do not allow any foreign matter in the cement bin.
- Do not allow particles larger than 1 1/2 inch in the aggregate bin.
- Do not allow the waterlines and flowmeters to freeze with water in them.
- Do not run the water pump dry.
- Do not continue to operate the machine if the hydraulic oil temperature exceeds 190°F.
- Wash out the auger within 20 minutes of the last use.
- Never attempt to operate the unit while in motion.

- Never attempt to repair the machine while in operation (always turn the power source off).
- Keep your entire body clear from all moving parts.
- Never attempt to walk on top of the aggregate bin to cross from the cement bin to the water tank (use the ladder).
- Never walk or stand under the auger.
- Never climb inside the aggregate bin (use a small pole to dislodge any aggregate that has bridged).
- Never enter the cement bin while in operation (there are moving parts inside the bin).

SLUMP TEST

The slump test is used to measure the consistency of a concrete mix. The test is normally performed by an Engineering Aid (EA) and is made by using a slump cone. The cone is 12 inches high with an 8-inch-diameter base and a 4-inch-diameter top (fig. 7-3).

A bucket is filled with a sample of the concrete from the discharge chute from the mixer. From this sample, the cone is filled in three layers. Each layer should contain approximately one third of the volume of the cone. Each layer is *rodded in* the cone with 25 strokes from a 5/8-inch-diameter tamping rod 24 inches long. The strokes should be distributed uniformly over the cross section of the cone and should penetrate into the underlying layer. The bottom layer should be rodded

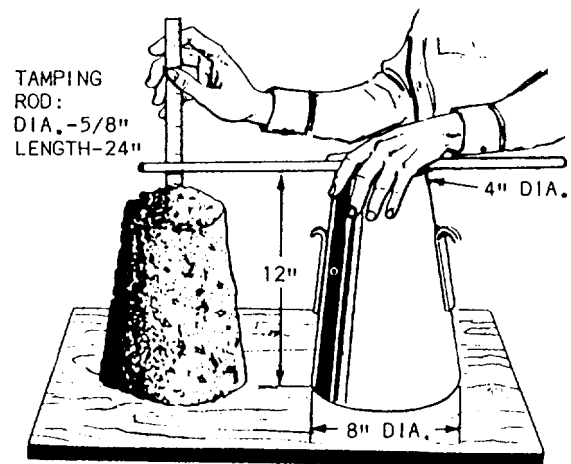

Figure 7-3.-Measurement of slumps.

throughout the depth. The strokes will eliminate any voids when the concrete is placed in the cone.

If the cone is overfilled, the excess concrete is made flush with the top of the cone with a straightedge. The cone is raised from the concrete by raising the cone carefully in a vertical direction. The slump is determined by measuring the difference between the height of the cone and the height of the concrete specimen (fig. 7-3). The slump is recorded in inches on the quality control report.

After the slump measurement is completed, the side of the mix is tapped gently with the tamping rod. The behavior of the concrete under this test is a valuable indication of the cohesiveness, workability, and placability of the concrete mix. If the mix is well-proportioned, tapping will only cause it to slump lower and retain its original identity, and a poor mix will crumble, segregate, and fall apart. Normally, the EAs perform three slump tests per truck load of concrete. Another test performed by the EAs on a concrete mix is a concrete strength test. This test is performed to control the quality of concrete manufactured in the field, to evaluate the performance of available materials used in a concrete mix, and to establish mix proportions that give concrete the required strength.

PLANT SAFETY

1. All personnel working in the batch plant area should wear hard hats at all times.
2. When hoppers are being charged with a clamshell or loader, personnel should stay away from the area of falling aggregate.
3. Housekeeping of the charging area is important. Keep the area clean and free of spoiled material and overflow.

4. Respirators must be worn by all personnel when handling bag or bulk cement.
5. Particular attention should be given to any rash or other irregularities of the skin as it might indicate "cement poisoning."
6. Vapor type of goggles should be worn by personnel in batch plant operations.

TRANSIT MIXER SAFETY

The use of transit mixers on construction projects impose traffic problems that must be considered. Caution must be used during backing of the transit mixer. Backing should be controlled by a signalman, positioned so the operator can clearly observe the directions given. Extreme caution must be used when traveling on a construction site. The stability of the mixer is greatly reduced with the extra weight of the concrete. Also, the weight of the mixer can crush newly placed underground utilities, sink in the mud, crack sidewalks, and so forth. In such cases, a slow speed is recommended.

Some additional safety precautions that must be enforced are as follows:

1. Reduce speed before making a turn or applying the truck brakes.
2. Secure the discharge chute properly, using the lock provided.
3. Check to make certain other personnel are in the clear before starting the mixer charging or discharging.
4. Make sure the mixer is stopped before making any adjustments.

CHAPTER 8

ASPHALT PLANT SUPERVISOR

The Naval Construction Force (NCF) uses various makes and models of asphalt plants in both the Atlantic and Pacific Fleet deployment sites. As an asphalt plant supervisor, you are a key member and share the responsibility for producing a quality mix. You must be aware of all operational functions of the plant and bring to the attention of the Alfa company operations chief any detected problems or potential problems. Additionally, you must be aware of all federal, state, and local regulations and ordinances relating to the operation of the plant, such as air and water pollution restrictions, anti noise requirements, restricted hours of operation, and so forth. Before deploying, contact the COMSECON/COMTHIRDNCB equipment offices for *Environmental Protection Agency (EPA)* directives, and operator's manuals that relate to the asphalt plant at your prospective deployment site.

ASPHALT PLANT SUPERVISOR RESPONSIBILITIES

This chapter presents the basic information concerning the operations of asphalt plants and the production and uses of bituminous materials. The Seabees need well-qualified personnel to operate and maintain asphalt plants. To ensure personnel are qualified, you must emphasize on-the-job training programs. Also, personnel must gain a thorough understanding of the manufacturers' operator and maintenance manuals.

An asphalt plant is an assembly of mechanical, computerized, electronic equipment where aggregates are blended, heated, dried, and mixed with asphalt to produce a hot-asphalt mix that meets specified requirements. An asphalt plant can be small, large, stationary, or portable. Whatever the size or configuration, every plant can be categorized as either a batch asphalt plant (fig. 8-1), a continuous-flow

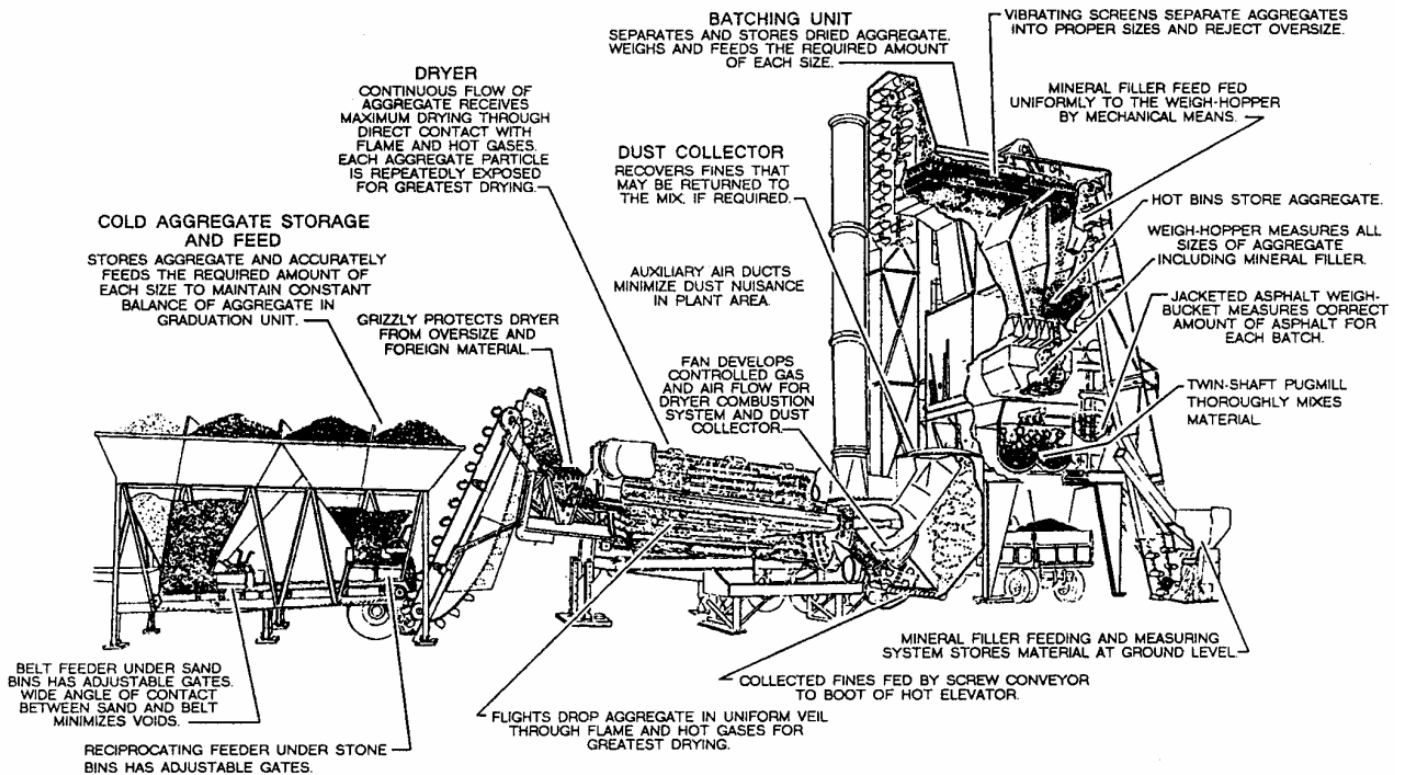

Figure 8-1.—Batch asphalt plant.

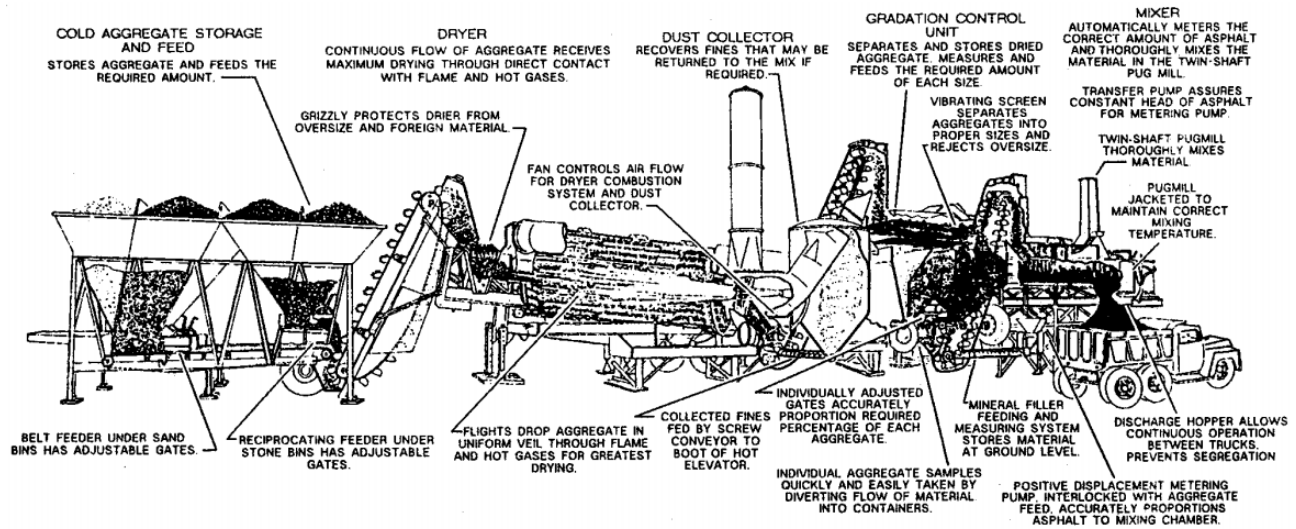

Figure 8-2.—Continuous-flow asphalt plant.

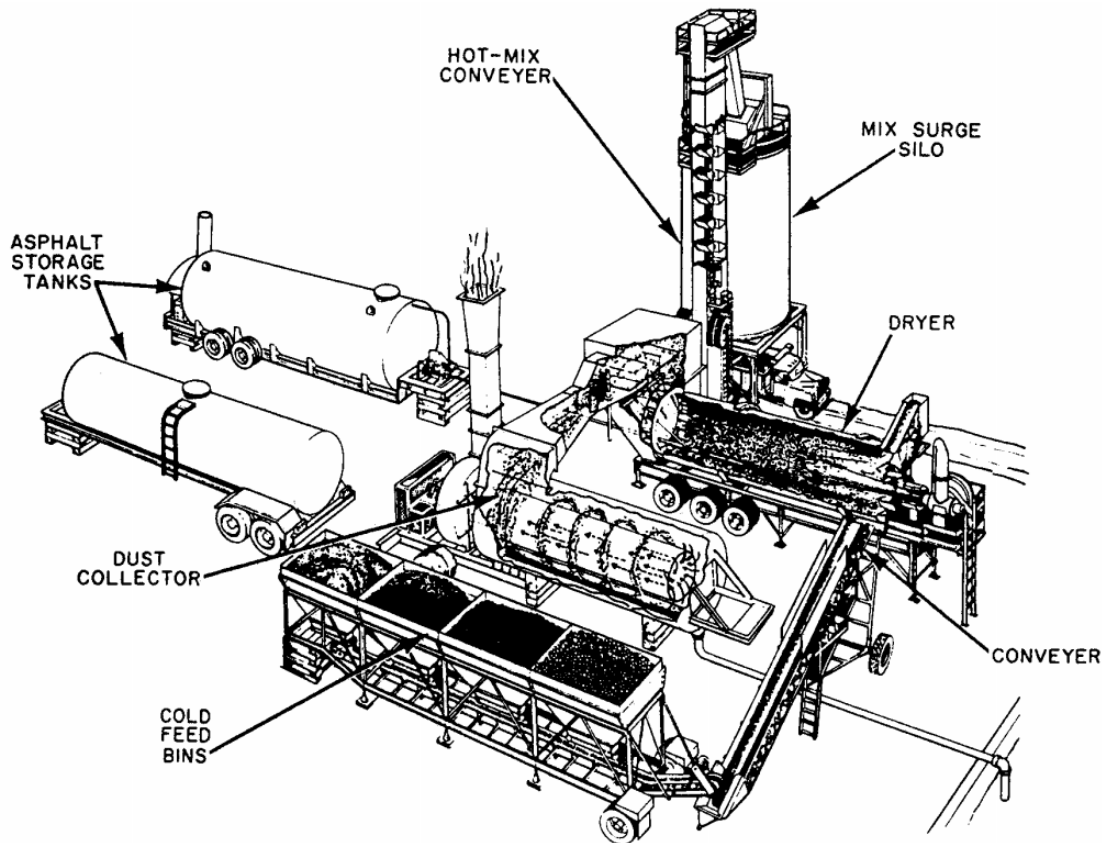

Figure 8-3.—Drum-mix asphalt plant.

asphalt plant (fig. 8-2), or a drum-mix asphalt plant (fig. 8-3).

ASPHALT PLANT OPERATIONS

Batch plants get their name because they produce hot mix in batches; one batch at a time, one after the other. The size of a batch varies according to the capacity of the plant pugmill (fig. 8-4).

Batch plants are distinguished from continuous-type plants, such as drum-mixers, which produce hot mix in a steady flow.

Aggregate Cold-Feed System

The aggregate storage and cold feed system (fig. 8-5) moves (unheated) aggregate from storage into the

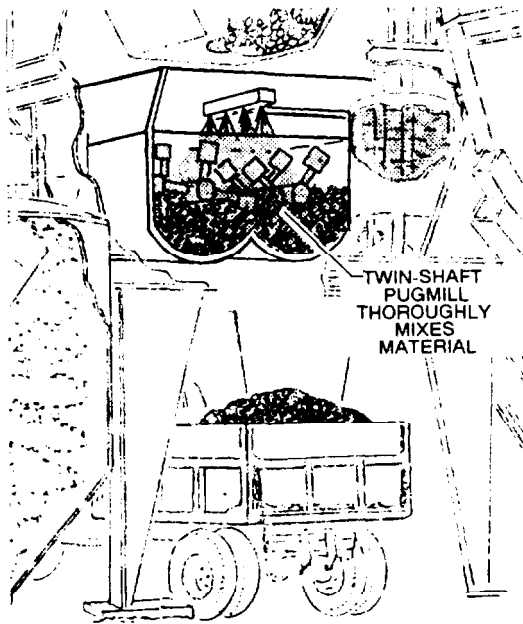

Figure 8-4.-Pugmill

plant. The feeder may be charged by a clamshell or front-end loader. Aggregate feeder units should have controls that can beset and secured to produce a uniform flow of aggregate to the cold elevator.

For a uniform OUTPUT from the asphalt plant, INPUT must be accurately measured. The importance of feeding the exact amounts of each size aggregate into the dryer at the correct rate of flow cannot be overemphasized.

The following conditions ensure a uniform flow of aggregate sizes:

- Correct sizes of aggregate in stockpiles.
- No intermixing of stockpiles.
- Accurately calibrated, set, and secured feeder gates.
- Gates kept free of obstruction.
- No excessive arching in the fine aggregates. Arching can be minimized by using rectangular (rather than square) openings above the feeders or placing

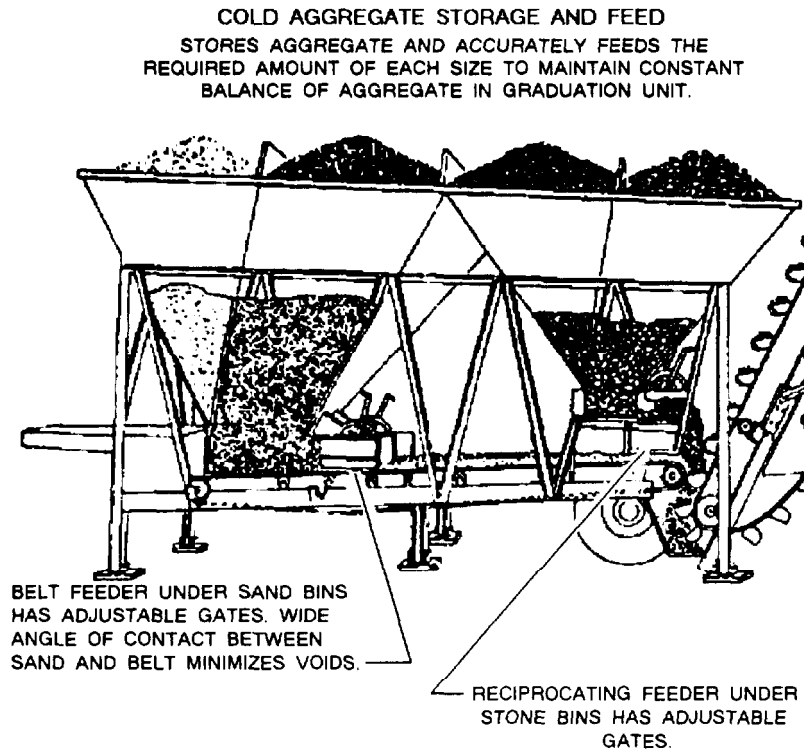

Figure 8-5.-Aggregate storage and cold-feed system.

GRADATION UNIT FEEDER GATES CALIBRATION GRAPH
CONTINUOUS MIX PLANT

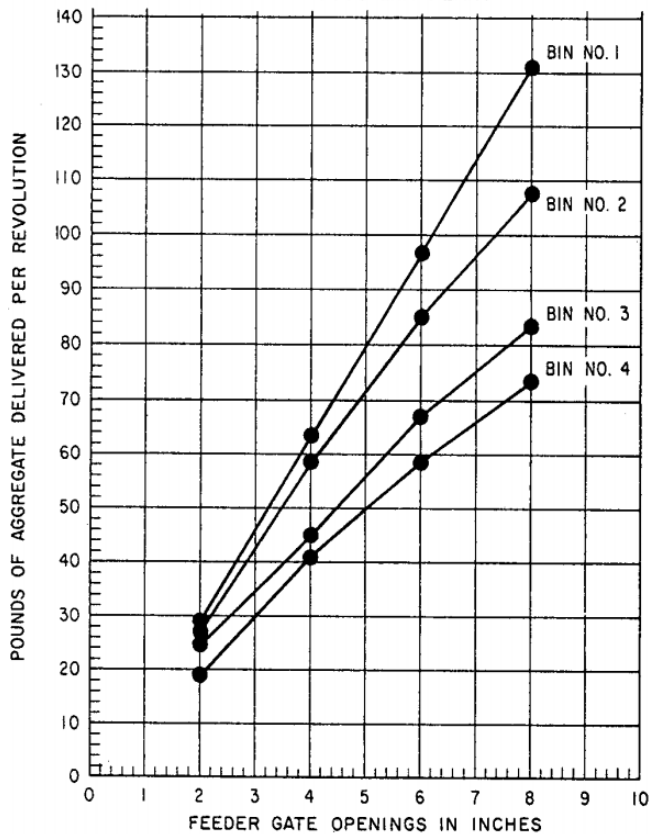

Figure 8-6.-Calibration chart, gradation feeder gates.

vibrators on the outside of the fine aggregate bins, or both. Vibrators should be wired to cut off automatically when the feeder stops. This eliminates excessive packing in the bin.

The following conditions underscore the need for proper cold feeding:

- Wide variations in the moisture content or in the quantity of a specific aggregate at the cold feed may cause a considerable change in the temperature of the aggregate leaving the dryer.

- A sudden increase in the cold feed can overload the screens, creating a carry-over of the fine aggregate into the coarse aggregate hot bins.

- Erratic feeding may cause some bins to overflow while starving others. This can result in the following problems:

1. Layers of variable grading in the hot bin gradation unit storage, especially in the fine bin, resulting in alternating rich and lean batches
2. An overloaded dust collection system

3. A reduced dryer draft

The cold aggregate feeder gates should be calibrated. Most manufacturers furnish approximate calibrations for the gate openings of their equipment. When these are available, they are helpful in making the initial gate setting. But the only accurate way to set gates is by making a calibration chart for each gate, using the aggregate to be used in the mix.

The gate opening (in inches or square inches) is plotted on the chart as the horizontal coordinate, and the pounds of material per revolution of the feeding mechanism (or pounds per minute) is the vertical coordinate. When the calibration chart is being prepared, the gate is set, usually at 25 percent or less of the total opening, and the feeder is started. When the feeder is running normally, the material is measured into a tare container and weighed at known time intervals (or number of revolutions). This gives one point on the calibration chart. The operation is repeated for three or more gate openings and the points connected on the chart (fig. 8-6). After the gates have been calibrated and locked, minor adjustments may be necessary to assure uniform production.

When the gates discharge on to the belt conveyer, their output may be checked by closing all of the gates except one, which is set at one of the calibration points. When the gates cannot be closed completely, it may be necessary to stop the feeder or disconnect it if it is mechanically driven.

The plant is started and brought to normal operating speed. Then the plant is stopped and the material from a measured section of the belt is removed and weighed, using care to remove all fines.

The weight of the material, divided by the length (in feet) of the belt section, multiplied by the belt speed (in feet per minute), will give the amount of material delivered per minute from the gate opening. The material from other gate openings is determined in the same manner and the gate calibration chart plotted as described above.

When variable speed drives are used to control belt feeders, calibration is simplified. The gate opening can be estimated, and the speed of the belt can be increased or decreased to deliver the required percentage and tonnage of aggregate.

In calculating the output of a gate for a given opening, deduct the weight of the surface moisture on the aggregate being weighed. This is very important

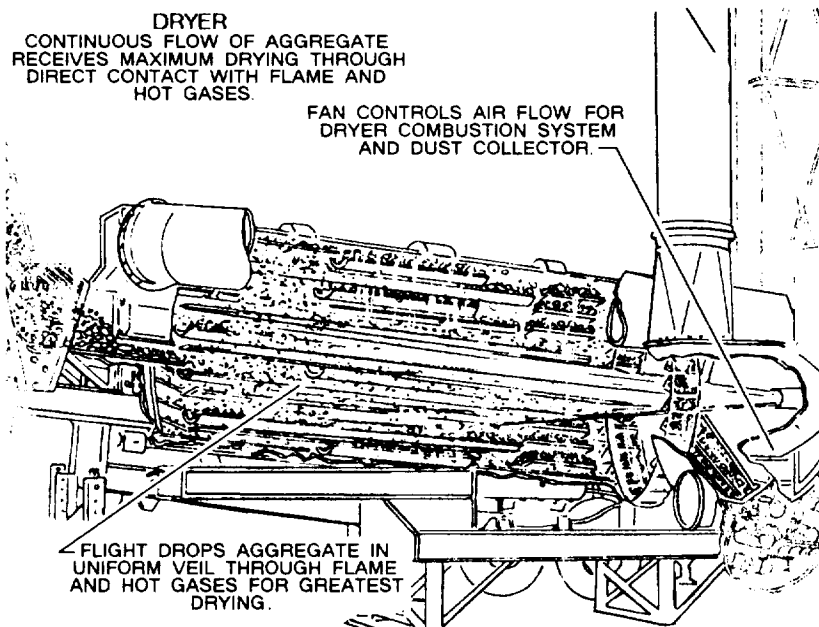

Figure 8-7.-Dryer.

when calibrating gates through which fine aggregates are flowing.

For uniform flow, gates that feed coarse aggregate should not be set at a height less than 2 1/2 to 3 times the largest aggregate size; for example, if a gate is feeding aggregate that has a maximum size of 1 inch, the gate should not be set at less than 2 1/2 or 3 inches. Sometimes it may be necessary to restrict the opening width to provide the necessary opening height.

Before you set the cold-feed gates, the production volume of the plant in normal operation must be determined. This can be estimated from the plant size (dryer, screening, and mixing capacities) and mixing cycle time. Then, using the gate calibration charts, each gate is set to deliver its share of the desired volume of aggregate.

Grading of the individual cold aggregate is determined by sieve analysis. The percentage of each size of aggregate to be used is calculated by trial and error.

The proportions required on the basis of these percentages will determine the gate settings. These settings should be checked by the same method used in calibrating the gate originally.

The setting should be considered tentative because the cold aggregate may vary in grading and moisture

with the weather and other conditions that will affect its bulking and flow.

The hot bins should be watched carefully and the cold aggregate feeders regulated to see that they do not run out of material or overflow.

Dryer

From the aggregate cold-feed system, aggregates are delivered to the dryer. The dryer (fig. 8-7) is a revolving cylinder in which the aggregate is dried and heated by an oil or gas burner. The cylinders used range from 3 to 10 feet in diameter and from 15 to 40 feet in length. A cylinder is usually equipped with longitudinal cups or channels (called lifting flights) that lift the aggregate and drop it in veils through the burner flame and hot gases. The slope of the cylinder, its speed, diameter, length, and the arrangement and number of flights control the length of time required for the aggregate to pass through the dryer.

The dryer performs two functions: (1) it removes moisture from the aggregate and (2) it heats the aggregate to mixing temperature.

The dryer includes an oil or gas burner with a blower fan to provide the primary air for combustion of the fuel and an exhaust fan to create a draft through the dryer. For efficient dryer operation, the air that is combined with the fuel for combustion must be in balance with the

amount of fuel oil being fed into the burner. The exhaust fan creates the draft of air that carries the heat through the dryer and removes the moisture. Imbalance among these three elements causes serious problems. With fuel oil, lack of sufficient air or excess flow of fuel oil can lead to incomplete combustion of fuel. The unburned fuel leaves an oily coating on the aggregate particles—a coating that can adversely affect the finished mixture.

Lack of balance between the blower air and draft air velocities can create back pressure within the dryer drum, causing *puff back* at the burner end. Puff back indicates that the draft is not sufficient to accommodate the air pressure being introduced by the burner blower. The solution is to increase the draft or to reduce the pressure of the blower air.

Dryer burners using natural gas or liquid petroleum gas rarely develop combustion problems; however, an imbalance between gas pressure, combustion air, and draft can occur. Make sure the gas burner you use is the correctly type for the pressure of the gas available.

The temperature of the aggregate, not the asphalt, controls the temperature of the mix. Overheating the aggregate can harden the asphalt during mixing. Underheating the aggregate is difficult to coat with asphalt and the resulting mix is difficult to place; therefore, a pyrometer, which is a reliable and accurate temperature-measuring device, should be installed in the dryer discharge in full view of your burner operator.

The pyrometers are sensitive instruments, designed to measure the very small electrical current induced by the heat of the aggregate passing over the sensing element. The pyrometer must be completely shielded from the heat and plant vibrations. The head of the device is usually located several feet away from the dryer and is connected to its sensing elements by wires. Any change in the connecting wire length, size, splice, or coupling will affect the calibration of the device and it must be recalibrated.

Two types of pyrometers are used. They are as follows: (1) the indicating pyrometer, which is usually located at the discharge chute of the dryer, and (2) the recording pyrometer. The recording head of this instrument is usually located in the plant control room.

The major difference between the indicating pyrometer and the recording pyrometer is that the indicating pyrometer gives a dial or digital reading, and the recording pyrometer records aggregate temperatures on paper in graph form providing a permanent record. Both types of pyrometers are quite similar in operation. Both pyrometers have a sensing element; that is, a

shielded thermocouple that protrudes into the main hot-aggregate stream in the discharge chute of the dryer.

Pyrometers should be cleaned periodically. Dust accumulating on them may cause a time lag in temperature measurement. They should also be checked frequently for accuracy. A simple way to do this is to put the sensing element of the pyrometer, together with an accurate thermometer, in an oil or asphalt bath. Being cautious of the flash point for the bath, slowly heat the oil or asphalt and compare readings from the pyrometer and thermometer. These readings should be taken at temperatures below, through, and above the expected operating temperature range.

Another means to check the accuracy of a temperature-indicating device is to take two shovel loads of hot aggregate from the dryer discharge chute and dump them in a pile on top of each other. The top shovel load of hot aggregate keeps the bottom shovel load of aggregate hot while the temperature is taken. Inserting the entire stem of an armored thermometer into the hot aggregate pile will give a temperature reading that can be compared to the reading on the pyrometer. Several thermometer readings may be necessary to get accurate temperature data.

A moisture check of the hot aggregate can be performed at the same time a temperature indicator check is performed. From the two shovel loads of aggregate, observe the aggregate for escaping steam or damp spots. These are signs of incomplete drying or porous aggregate releasing internal moisture which may or may not be a problem. Another procedure used to check the moisture content is to take a dry, clean mirror, shiny spatula, or other reflective item and pass it over the aggregate slowly and at a steady height. Observe the amount of moisture that condenses on the reflective surface. With experience, you will be able to detect excessive moisture consistently. These quick-moisture checks are useful in determining whether a more precise laboratory moisture test should be performed.

Dust Collector

Manufacturers have designed asphalt plants to have equipment that restrict the escape of pollutants from the plant. Even so, during the operation of an asphalt plant, some gaseous and particulate pollutants may escape into the air. These pollutants must be controlled and limited to meet established clean air regulations. As the supervisor, you must be fully aware and familiar with the local laws concerning air pollution.

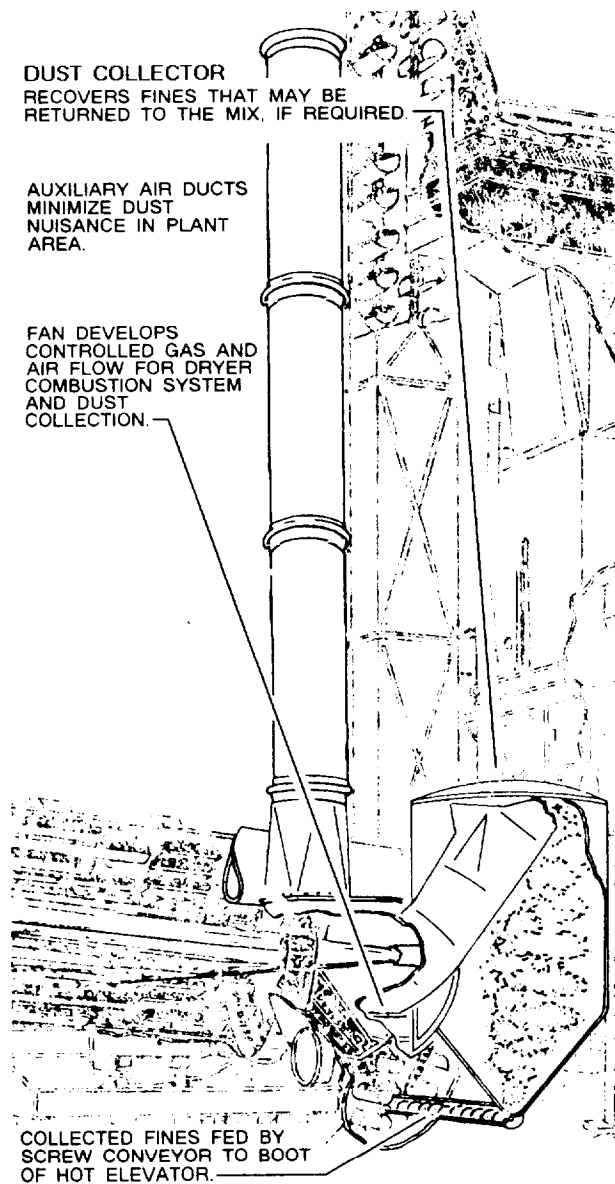

Figure 8-8.-Dust collector.

A major air pollution concern at an asphalt plant centers around the combustion unit. Dirty, clogged burners and improper air-fuel mixtures result in excessive smoke and other undesirable combustion products; therefore, close attention to the cleanliness and adjustment of the burners and accessory equipment is very important.

Another source of air pollution is aggregate dust. The greatest dust emissions from the plant come from the rotary dryer. Dust collectors are installed at this location to reduce dust emissions to a level that meets anti-air-pollution requirements.

Most dust collectors (fig. 8-8) are centrifugal (cyclone) units, either horizontal or vertical with single

or multiple shells. Dust particles enter the top of the dust collector in the current of draft air from the dryer, drawn by the fan(s) that pull(s) the flame and the hot gases through the dryer. In the collector, the dust-laden air is forced into a whirling motion.

Heavier dust particles in the exhaust gas stream are separated by centrifugal force against the collector shell and are carried to the lower outlet. If the collector works efficiently, the finer dust that remains in suspension is carried out the exhaust stack with the air. The fines collected at the bottom of the cyclone are normally picked up by a dust-return auger and returned to the plant or wasted.

When required by specifications, a baghouse or wet wash system is added to the dust-collecting system. Several types of wet systems are used. They usually consist of a short tower, with or without baffles, or multiple horizontal tubes with spirals. The washer swirls the high-velocity exhaust coming from the dust collector through a fog and a fine spray to wash the gas. The dampened fines are thrown to the sides by centrifugal force. The material washes down the sides and discharges, with the water, out the bottom of the washer. The wastewater containing the dust must be properly handled to prevent it from becoming another source of pollution. Use of a wet wash system requires a large source of water. Also, the output of the fan in the dust collector must be increased by 10 to 20 percent because of pressure loss in the tower.

The baghouse is a large metal housing, containing hundreds of synthetic, heat-resistant fabric bags. The bags are usually silicone-treated to increase their ability to collect and retain very fine particles of dust. The function of the baghouse is similar to the function of a vacuum cleaner. A large vacuum fan creates a suction within the housing that draws in dirty air and filters it through the fabric of the bags. A typical unit may contain as many as 800 bags to handle the huge volume of exhaust gases from the aggregate dryer. Eventually, they accumulate into what is called a "dust cake" that must be removed before it reduces or stops the flow of dirty air through the filter. Several methods for cleaning the bags in the baghouse are used; however, the most commonly used methods are as follows: flex the bags, back flush the bags with clean air, or flex and back flush the bags. The Jet-Pulse system is another method which is similar to the back flush in that it produces a pulse of positive pressure within the bag to dislodge the "dust cake." Dust removed from the bags drops into an auger at the bottom of the baghouse and is normally

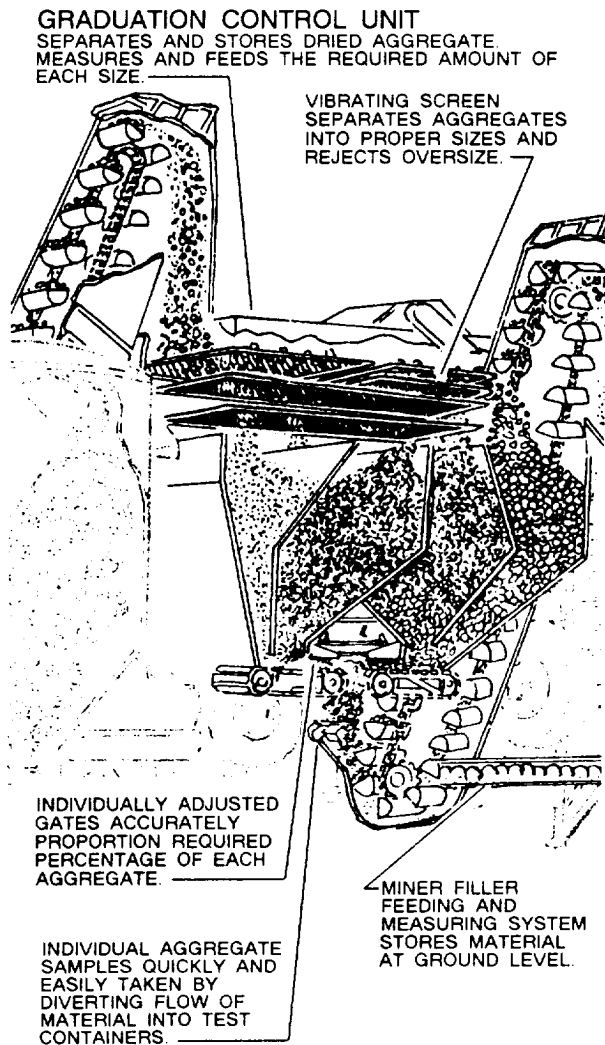

Figure 8-9.-Gradation control unit.

transferred to a storage silo. This material is often used in the hot mix.

When the material removed from the dust collector can be recombined satisfactorily with the aggregates in the mix, some or all of it may be returned to the plant. The amount returned depends upon the combined grading of the finished mix. When the collected dust is unsatisfactory or is prohibited by the mix specifications, it is removed from the bottom of the collector and wasted.

Hot Screens

After the aggregates have been heated and dried, they are carried by a hot elevator to the gradation unit. In the gradation unit, the hot aggregate passes over a

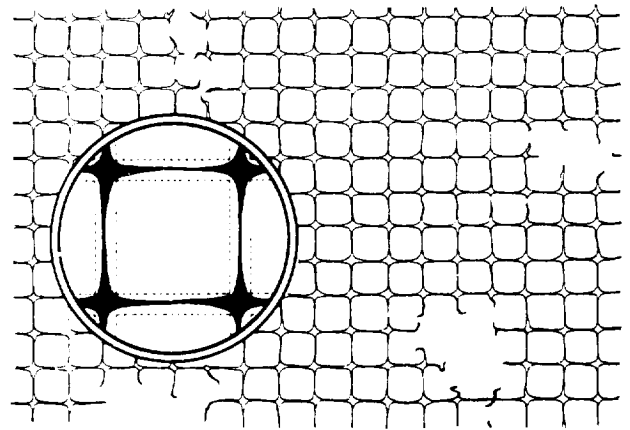

Figure 8-10.-Screen wear.

series of screens. The function of the screens is to separate the hot aggregate into the specified sizes accurately and deposit those sizes in hot bins.

The gradation control unit (fig. 8-9) or screening unit includes a set of several different-sized vibrating screens. The top screen is a scalping screen that rejects and carries off oversized aggregates. This is followed by one or two intermediate-sized screens, decreasing in size from the top to bottom. The very bottom screen is normally a sand screen. The effective screening area must be large enough to handle the maximum amount of feed delivered to separate the hot aggregates properly; therefore, the capacity of the screens should be checked against the capacity of the dryer and the capacity of the pugmill.

When too much material is fed to the screens or the screen openings are plugged, many particles that should pass through ride over the screen and drop into a bin designated for larger sized aggregate. When screens are worn (fig. 8-10) or torn, resulting in enlarged openings and holes, oversized material will go into bins intended for smaller sized aggregate. Fine aggregate misdirected into bins intended for larger aggregate is known as "carry-over."

Carry-over can cause a lack of uniformity in the aggregate gradation and in the mixture. Additionally, excessive carry-over adds to the amount of fine aggregate in the total mix, thus increasing the surface area to be coated with asphalt. Excessive carry-over, or its fluctuations, can be detected by a sieve analyses made from the contents of the individual hot bins and must be corrected immediately. Corrective measures include the cleaning of screens, the regulation of the quantity of material coming from the cold feed, or a combination of both. Some carry-over is permitted in normal screening;

however, the permissible amount in each bin is usually specified.

Daily visual inspection of the screens for cleanliness is recommended, preferably before the start of operation. When conditions warrant, the screens should be cleaned.

NOTE: Always make sure the bolts securing the screens are tight.

Hot Bins

Hot bins are used to store the heated and screened aggregates temporarily in the various sizes required. Each bin is an individual compartment or a segment of a large compartment divided by partitions. A properly sized hot-bin installation should be large enough to prevent running out of material when the mixer is operating at full capacity. Bin partitions should be tight, free from holes, and of sufficient height to prevent intermingling of the different size aggregates.

Hot bins usually have indicators that tell when the aggregates fall below a certain level. These indicators may be either electronic or mechanical. Each hot bin should be equipped with an overflow pipe to prevent excess amounts of aggregate from backing up into the other bins. The overflow pipes should be set up to stop overflowing of the bins. When a bin overfills, the screen above the bin rides on the aggregate, resulting in heavy carry-over and possible damage to the screen. Overflow vents should be checked frequently to ensure they are free flowing.

Sometimes, very fine aggregate particles build up in the bin corners. When this buildup of aggregate collapses, it can result in an excessive amount of fines in the mix. This rush of fine materials normally occurs when the aggregate in the bin is drawn down too low. This condition can be controlled by having fillet plates welded in the bin corners to eliminate the 90-degree angles and by maintaining the proper aggregate level in the bin.

Other potential obstacles to obtaining a good mix includes a shortage of aggregate in one bin or excess in another bin, worn gates (at the bottom of the bins) allow leakage of aggregate, and sweating of the bin walls. These obstacles must be overcome. Bin shortages or excesses can be corrected by adjusting the cold feed. Sweating occurs when moisture vapor in the aggregate and in the air condenses on the bin walls. This usually happens only at the beginning of the day's operation or when the coarse aggregate is not thoroughly dried.

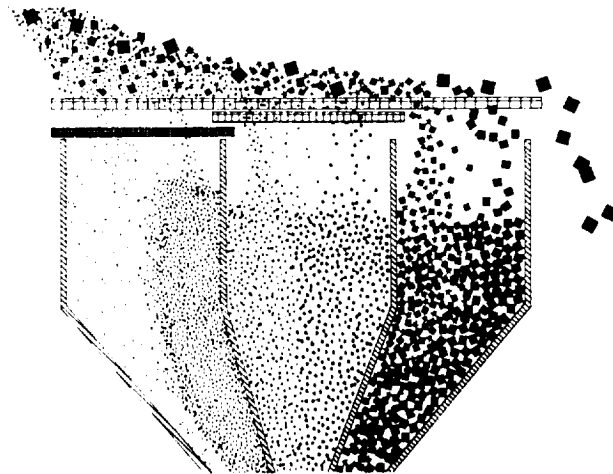

Figure 8-11. Segregation of material in the hot bins.

Sweating may accumulate dust that, when released suddenly, will add unwanted fines in the mix.

Hot-Bin Sampling

Most modern hot-mix asphalt plants are equipped with devices for sampling hot aggregate from the bins. These devices vary in design but usually serve to divert the flow of aggregate from the feeders, or gates, under the bins into sample containers. On continuous-flow plants, the best place to obtain a sample is from the feeder gates as the material is deposited onto the elevator leading to the pugmill. Sampling facilities must be constructed and located so that the samples obtained will be representative of the material in the bins.

From the flow of aggregate over the screens, the finer aggregates fall to the near side of the bins and coarser aggregates fall to the far side (fig. 8-11). When the aggregate is drawn from a bin by opening a gate at the bottom, the flow of aggregate consists predominantly of fine aggregate at one edge and coarse aggregate at the other; therefore, the position of the sampling device in the flow of aggregate determines whether the sample will be composed of the fine portion, the coarse portion, or will be an accurate representation of all the aggregate in the bin. This condition is critical in the bin that contains the fine aggregate since the asphalt required in the mix is influenced heavily by the aggregate from this bin.

Stratification (vertical layering) of sizes in the fine bin may be caused by variation of grading in the stockpiles or by erratic feeding of the cold aggregate. When this form of segregation exists, representative

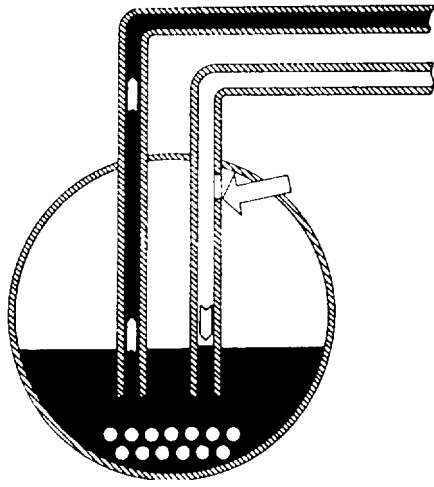

Figure 8-12.-Asphalt return line.

samples cannot be obtained even when the sampling device is used correctly.

Asphalt Heating and Circulation

Provisions should be made for the circulation of the asphalt through the feeding and storage system. All storage tanks, transfer lines, and pumps should have heating coils and/or jackets to maintain the asphalt at the required temperature.

Return lines discharging into the storage tanks should be submerged below the asphalt level in the tank to prevent oxidation of the asphalt. When the pump is reversed, two or three vertical slots should be cut in the return line within the tank to break the vacuum in the lines. The slots should be cut above the high level mark of the stored asphalt (fig. 8-12).

To assure temperature control of the asphalt, you should place an armored thermometer or a pyrometer with a recorder in the asphalt feed line at a location near the discharge valve at the mixer unit. Also, the asphalt storage tank should be equipped with a recording thermometer, having a minimum time range of 24 hours.

An approved valve or spigot should be installed in the tank or in the circulating system to provide a means for sampling the asphalt. Sufficient material must be drawn and wasted before the sample is taken to ensure the material obtained is truly representative of the storage supply.

When the temperature of the asphalt is maintained by circulating heating oil, the level of the hot oil in the reservoir of the heating unit should be inspected

frequently. If the hot-oil level falls, check for leakage of the hot oil into the stored asphalt.

Temperature of Mixture

Both asphalt and aggregate must be heated before they are combined in the pugmill. The asphalt is heated to make it fluid enough to coat the aggregate particles. The aggregate is heated to make it dry and hot enough to keep the asphalt in a fluid state while it is coating the particles.

Asphalt is a thermoplastic material that decreases in viscosity with increasing temperature; however, the relationship between temperature and viscosity may not be the same for different sources or types and grades of asphalt material.

The temperature of the aggregate controls the temperature of the mixture, and a mixing temperature normally is specified based on factors relating to placement and compacting conditions. Another consideration is the temperature required to dry the aggregate sufficiently to obtain a satisfactory mix.

Mixing should be accomplished at the lowest temperature that provides complete coating of the aggregate particles and a mixture of satisfactory workability. Table 8-1 provides a guide for suggested asphalt temperatures ranges.

Mineral Filler

Mineral filler is a fine material (dust) that passes through the No. 200 sieve during a sieve analysis. Mineral filler is normally part of the asphalt mix design, used to fill in the voids of the aggregates. Mineral fillers commonly used are the following: portland cement, pulverized limestone (limestone dust), silica, and hydrated lime.

High production plants often have a separate feeding system for introducing mineral filler into the asphalt mix. Part of this system is a storage silo that maintains several days supply of mineral filler. A receiving hopper, screw conveyer, and dust elevator are used to charge the storage silo, and a vane feeder meters the filler introduced into the mix. The ultimate choice of this system is usually dependent on the availability of bulk filler and their price in relation to bagged fines.

In plant operations where the volume of filler required does not justify a bulk silo, a bag feeding system is used. This system consists of a ground-mounted feeder, dust-tight elevator, surge hopper, vane feeder or screw conveyer, and an overflow chute.

Table 8-1.Suggested Asphalt Temperature Ranges

Type and Grade of Asphalt	Pugmill Mixing Temperature of Aggregates*	Distributor Spraying Temperature
Asphalt Cements		
(For Open-Graded Mixes, Types I & II)**		
40-50	225°F-310°F	
60-70	225°F-305°F	
85-100	225°F-300°F	
120-150	225°F-300°F	
200-300	225°F-300°F	
(For Dense-Graded Mixes, Types III-VIII)**		
40-50	275°F-350°F	
60-70	265°F-330°F	
85-100	255°F-325°F	
120-150	245°F-325°F	
200-300	225°F-300°F	
(For Distributor Spray Applications)		
40-50***		300°F-410°F
60-70***		295°F-405°F
85-100		290°F-400°F
120-150		285°F-395°F
200-300		275°F-385°F
Liquid Asphalts		
RC, MC, and SC Grades		
30	60°F-105°F	
70	95°F-140°F	
250	135°F-175°F	
800	165°F-205°F	
3000	200°F-240°F	
Asphalt Emulsions		
RS-1	****	75°F-130°F
RS-2	****	110°F-160°F
MS-2	50°F-140°F	100°F-160°F
SS-1	50°F-140°F	75°F-130°F
SS-1h	50°F-140°F	75°F-130°F
RS-2K	****	75°F-130°F
RS-3K	****	110°F-160°F
CM-K	50°F-140°F	100°F-160°F
SM-K	50°F-140°F	100°F-160°F
SS-K	50°F-140°F	75°F-130°F
SS-Kh	50°F-140°F	75°F-130°F

*The temperature of the aggregates and asphalt immediately before mixing should be approximately that of the completed batch.

**Mix Type III is intermediate between dense- and open-graded mixes. As the gradation of the mix changes from dense-graded to open-graded, the mixing temperature should be lowered accordingly.

***Not normally used for spray applications in pavement construction.

****Not used for mixing.

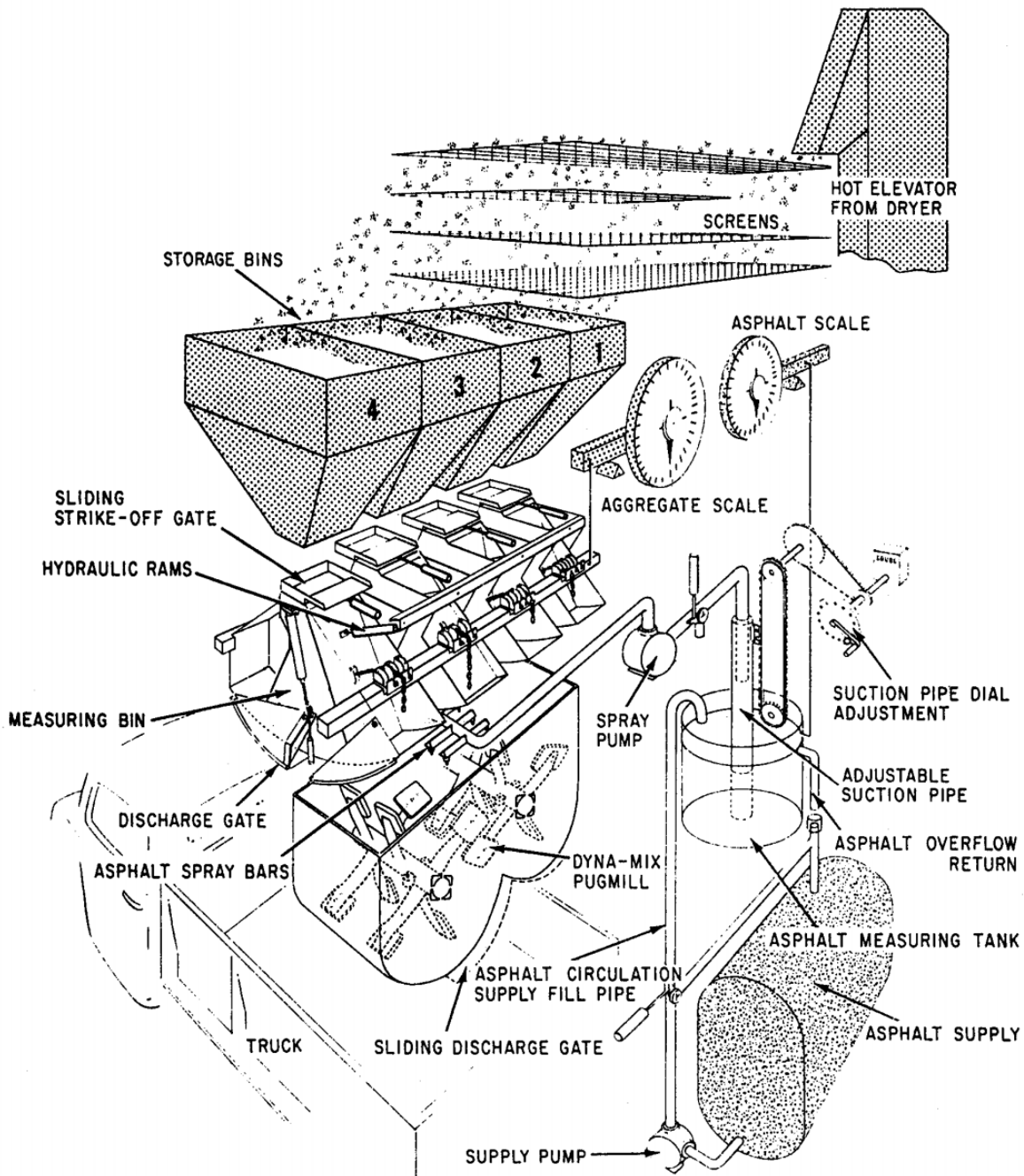

Figure 8-13.—Batch asphalt plant hatching unit aggregate weigh-hopper.

Bulk or bag filler systems are equally adaptable for continuous-flow asphalt plants. Final metering of the filler to the mix is accomplished through a variable speed vane, a screw feeder, or a belt feeder, depending on the material to be handled and the capacity required. In each case, the mineral filler feed is interlocked with the aggregate and asphalt feed to ensure constant accuracy.

When an excess of filler is encountered in the raw aggregate feed, a bypass system can be used to receive the fines collected by the dust collector. The

required amount of fines is then fed back to the mix, and any surplus amounts are diverted to a storage bin for disposal or other use.

BATCH ASPHALT PLANT

The batch asphalt plant is shown in figure 8-1. The cold aggregate storage and feed system, dryer, and dust collector are both similar in operations for both the batch and continuous-flow type of asphalt plant. A distinguishing feature of the batch plant is the batching unit shown in figure 8-13. Here the dried hot aggregate

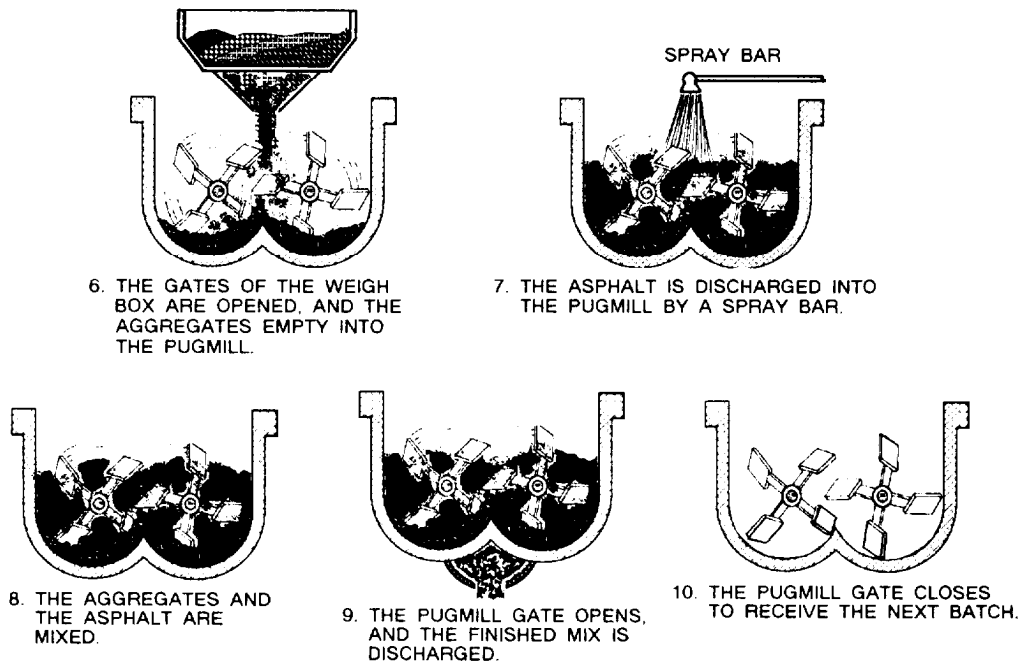
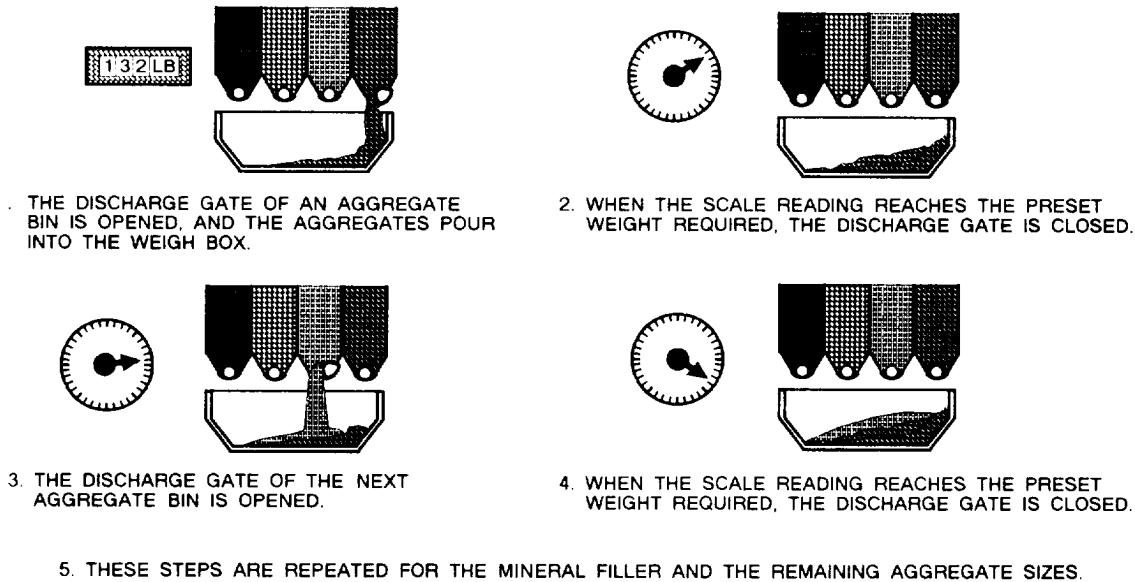

Figure 8-14. Typical batch plant cumulative scale settings and cycle.

is screened into different sizes and stored by size in separate bins.

From the hot bins the aggregates are deposited into a weigh-hopper. Coarse aggregates are usually the first to be deposited into the weigh-hopper, the intermediate-size aggregates next, and the fine aggregates last. This sequence is designed to place the fines of the aggregates at the top of the aggregates deposited in the weigh-hopper where they cannot leak out through the gate at the bottom of the weigh-hopper. This system also allows the most efficient utilization of

the available volume in the weigh-hopper. The weigh-hopper is suspended from scale beams and the scales indicate the weight of the full amount of aggregate entering the hopper.

When each size of aggregate is deposited into the weigh-hopper, the weights to be drawn from the hot bins are marked on the scale dial. Because the scales indicate the weights cumulatively, the dial must be marked accordingly. Figure 8-14 shows how the cumulative scale settings are used to control the proportion of aggregates drawn from each bin.

Asphalt Introduction

From the weigh-hopper, the aggregates are deposited into the plant pugmill (mixing chamber) and are blended with the proper proportion of asphalt. In a typical plant system, asphalt is weighed separately in a weigh bucket before being introduced into the pugmill. When the asphalt reaches a predetermined level in the weigh bucket, a valve in the delivery line closes to prevent excess asphalt from being discharged into the bucket. The asphalt is then pumped through spray bars into the pugmill. Asphalt buckets should be checked for accuracy in the mornings. New asphalt loosens some of the old asphalt that accumulated the previous day on the sides and bottom of the bucket. Loss of this accumulated asphalt changes the tare weight of the bucket.

Pugmill Mixing

Asphalt and aggregates are blended in a chamber called the pugmill. The pugmill consists of a lined mixing chamber with two horizontal shafts on which several paddle shanks, each with two paddle tips, are mounted. The paddle tips are adjustable and fairly easily replaced.

The paddle areas are adjusted to ensure there are no "dead areas" in the pugmill. A "dead area" is a location where aggregates can accumulate out of reach of the paddles and not be thoroughly mixed. Dead areas can be avoided by making sure the clearance between the paddle tips and the liner is less than one half of the maximum aggregate size.

Nonuniform mixing can occur if the pugmill is overfilled (fig. 8-15). When the plant is operating at full production, the paddle tips should be barely visible at the surface of the material during mixing. If the material is too high, the surface aggregates will tend to "float" above the paddles and will not thoroughly mix. Conversely, in a pugmill containing too little aggregate (fig. 8-15), the tips of the paddles rake through the material without mixing it. These problems can be avoided by following the manufacturer's pugmill batch rating recommendation. Normally, the rating is based on a percentage of the capacity of the pugmills "live zone." This live zone (fig. 8-15) is the net volume in cubic feet below a line extending across the top arc of the inside body shell radius with shafts, liners, paddles, and tips deducted.

Figure 8-14 presents the mixing cycle during which the aggregates, mineral filler, and asphalt are blended in asphalt hot mix in the pugmill. The length of time

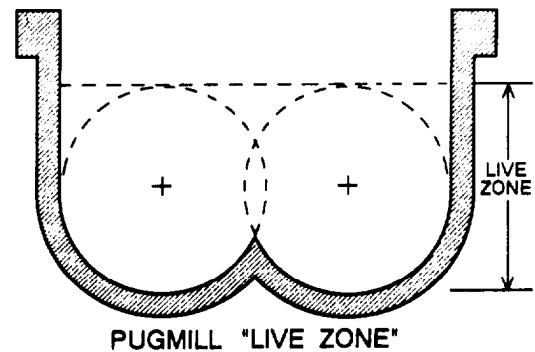
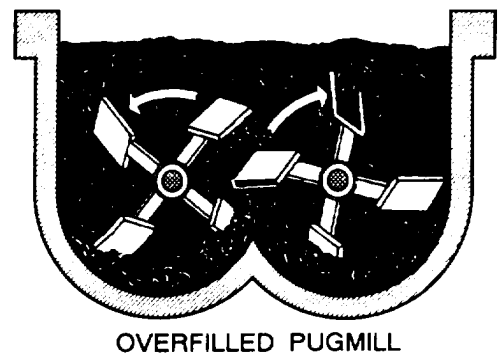
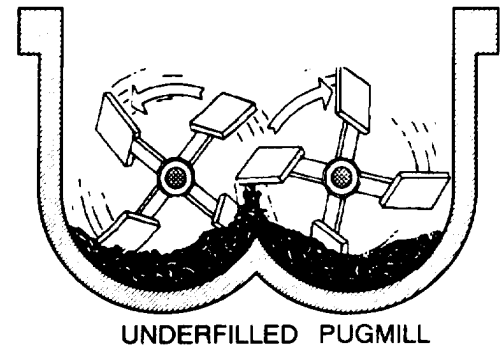

Figure 8-15.-Typical pugmill.

between the opening of the weigh box gate (Step 6 in the figure) and the opening of the pugmill discharge gate (Step 9) is referred to as the batch mixing time. The batch mixing time must be long enough to produce an homogeneous mixture of evenly distributed and uniformly coated aggregate particles. If the mixing time is too long, the lengthy exposure of the thin asphalt film to the high-aggregate temperature in the presence of air can affect the asphalt and reduce the durability of the mix. The speed of the mixer shafts and the arrangement and pitch of the paddles are factors governing the efficiency of the mixing. Most job specifications require the use of a timing device to monitor batch mixing time.

Discharge Gate

Little time is lost in discharging a completed batch through the hydraulically actuated discharge gate because there is no segregation of materials. The gate opens across the entire length of the paddle shafts and across the width (distance between the paddle shaft centers) of the pugmill. Being relatively large, the gate opening permits access from the bottom for maintenance and replacement of parts.

Plant Automation

The batch asphalt plant is almost completely automated. After mix proportions and timers are set and the plant is started, the plant repeats the weighing and mixing cycles until stopped by the operator or until a shortage of material or some unexpected malfunction causes the plant to shut down itself.

The plant operator's manual provided by the manufacturer, provides details on the setup and adjustment of the automatic equipment. You must check the accuracy and adjustment of this equipment, particularly the aggregate scales, asphalt scales or meters, batching controls, and recording equipment (if used). This should result in trouble-free production; moreover, the entire plant should be checked periodically to ensure the finished product meets specifications.

CONTINUOUS-FLOW ASPHALT PLANT

The continuous-flow asphalt plant is shown in figure 8-2. Continuous-flow asphalt plants are equipped with positive displacement asphalt pumps. One type is regulated by changing the drive sprockets or gears that are mechanically interlocked with the aggregate feeders (fig. 8-16). The other is controlled by a calibrated remote control handwheel on the mixer operator platform. When using the former type, you must use the manufacturer's tables as a basis for determining the proper pump and sprocket combinations to fix the amount of asphalt discharge. By doing so, you can control the feeder gates and asphalt pump while ensuring no change in setting can be made without the knowledge of the asphalt plant supervisor.

The temperature of the asphalt going through the positive displacement asphalt pump must be known at all times to maintain constant asphalt proportioning. You should take frequent readings of the thermometer installed in the circulating line just ahead of the pump. This allows you to make any necessary adjustments to

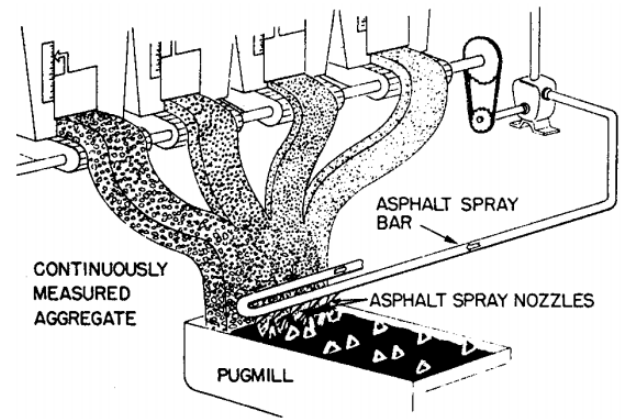

Figure 8-16.-Spray-bar operation with asphalt distribution mechanically interlock with aggregate feeders.

compensate for volume changes in the asphalt when substantial temperature changes occur.

Pugmill Mixer

The function of a continuous-flow plant pugmill is almost identical to the pugmill in the batch mix plant. The primary difference is that the mixing principle is different. In a batch mixer, the materials are confined in the mixing chamber. In a continuous-flow plant pugmill mixer, the materials are propelled toward the discharge. The mixing pressure varies with the height or weight of material in the pugmill that can be controlled by adjusting the dam gate at the discharge. The height of material in the pugmill mixer should not be allowed to rise above the paddle tips, with the exception of the last set of paddles.

To improve the mixing efficiency of the pugmill, you should make the following adjustments:

1. Raise the dam on the discharge end of the mixer to hold the material in the mixing unit for a longer period of time at a depth that will further intensify the mixing action.
2. Adjust or reverse the pitch of the paddles to retard movement of the material through the pugmill and increase the degree of mixing action within the unit.

Nonuniform mixing can occur if the mixer is overfilled. At maximum operating efficiency, the paddle tips should be barely visible in the material at the top of the arc during mixing. The batch rating of the pugmill for the continuous-flow plant is the same as for the batch plant.

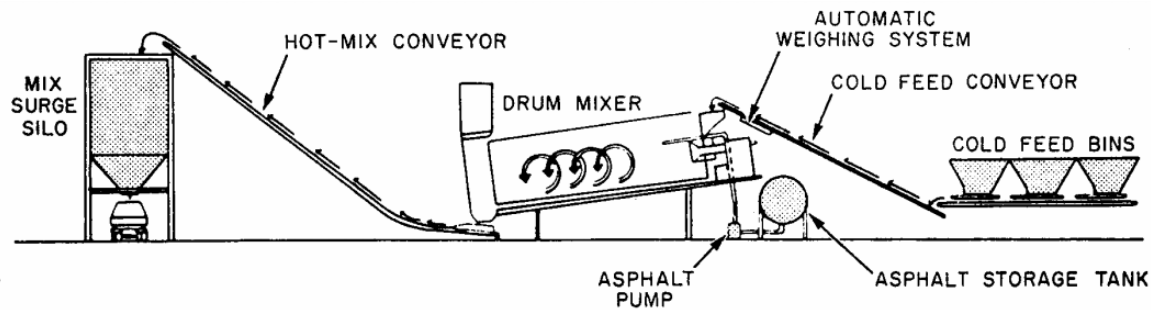

Figure 8-17.-Basic drum-mix asphalt plant

Mixing Time

Total mixing time begins when all the combined mineral aggregates are in the mixer and ends when the mixer discharge gate is opened. Dry mixing time, when specified, begins when all the combined mineral aggregates are in the mixer and ends with the introduction of the asphalt. Wet mixing time begins with the start of the asphalt application and ends with the opening of the mixer discharge gate.

The asphalt film on aggregate is hardened by exposure to air and heat; therefore, mixing time should be the shortest time required to obtain a uniform distribution of aggregate sizes and a uniform coating of asphalt on all aggregate particles. The speed of the mixer shafts and the arrangement and pitch of the paddles are factors governing the efficiency of the mixing.

To aid further the operation of a continuous mix plant, you can add or extend several automatic controls. These include the following:

1. Automatic burner controls
2. Automatic mix discharge
3. Automatic mixer and gradation cutoffs in case of hot-bin shortage or improper feed
4. Electric interlocks that shut down the complete plant in case of a failure anywhere in the electric system

The operator's manual for the particular plant being used gives details on the setup and adjustments of the automatic equipment included with the plant.

NOTE: Normally all automatic systems have manual override. You should know where it is located and how to use it. See the manufacturer's manual for specific details.

DRUM-MIX ASPHALT PLANT

The drum-mix plant is shown in figure 8-3. The mixing drum for which the plant is named is very similar in appearance to the batch plant dryer drum. The difference between the two is that in a drum-mix plant the aggregate is not only dried and heated within the drum, but it is also mixed with the asphalt cement. In a drum-mix plant, there are no gradation screens, hot bins, weigh-hoppers or pugmills. Aggregate gradation is controlled at the cold feed.

The basic plant consists of a cold-feed system, a rotating drum dryer, an asphalt proportioning and dispensing system, and a surge silo (fig. 8-17). The ease of setup and operation of the drum-mix plant makes it the ideal machine for operations.

Aggregate Storage and Feed

Aggregate gradation and uniformity are entirely dependent on the cold-feed system. Proper care must be exercised not only in producing the aggregate but also in storage. Aggregates used for drum-mix plants must be received, handled, and stored to ensure there is no danger of contamination or intermingling.

Stockpiles must be properly graded and split into different sized fractions to control the gradation of the mix properly. Uncorrected segregated stockpiles will result in mix gradation difficulties. The plant supervisor should establish and maintain stockpiles in the most economical manner and correct any deficiencies in uniformity before the aggregate is fed into the mixing plant.

Since the typical drum-mix plant does not have a gradation unit, the aggregate must be proportioned before entering the mixing drum. This is accomplished with a multiple-bin cold-feed system equipped with precision belt feeders for control of each aggregate.

Under each bin is a belt feeder upon which the aggregate is proportioned.

The plant should be equipped with a means to obtain samples of the full flow of aggregates from each cold feed and the total cold feed. These samples are required to perform a sieve analysis of the dried aggregate.

Cold feed controls consist of the following:

1. Sieve analysis of aggregate in each bin.
2. Calibrate feeders—both belt speed and gate opening.
3. Established bin proportions.
4. Set belt drive speeds and gate openings.

Once the gates are calibrated, they should be checked regularly to ensure they remain properly set. All settings should be considered tentative because the cold aggregate used in the mix normally varies in grading and moisture content; therefore, adjustment of the gates is required to maintain a uniform flow.

Drum-mix plants require the use of a continuous weighing system on the cold-feed conveyer belts. In-line belt weighers, known as weigh bridges, are belt-weighing devices used to weigh the combined aggregate passing over the conveyer belt. A readout indicates the weight of the flow over the scales at any given instant. No material should ever be diverted from the conveyer belt after it passes the belt weigher.

The in-line belt weigher is usually located between the head and tail pulley of the cold-feed belt conveyer. This location tends to lessen variations in readings caused by impact loading, rollback of aggregate, or changes in belt tension.

In drum-mix plants the aggregate is weighed before drying. Undried aggregates may contain an appreciable amount of moisture that can influence the weight; therefore, an accurate measurement of the moisture content is important. From the weight measurement, adjustments can be made to the automatic asphalt metering system to ensure that the amount of asphalt delivered to the drum is correct for the amount of aggregate minus its moisture content.

The moisture content of the cold-feed aggregates should be monitored at the beginning of each day and about the middle of the day. When conditions make the moisture content vary, it should be checked more frequently.

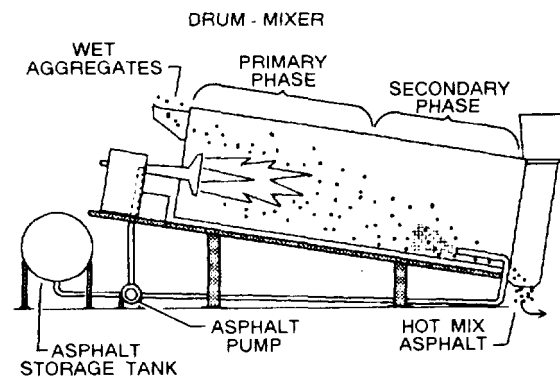

Figure 8-18.-Drum mixer zones

Asphalt Metering

The drum-mixer is normally equipped with a system to add asphalt to the aggregate inside the drum mixer. Called the asphalt metering and delivery system, it is a continuous mechanical proportioning system interlocking with the aggregate weigh system to ensure the exact asphalt content of the mix. The weight of the aggregate delivered into the mixer, as measured by the weigh belt, is the basis for determining the quantity of asphalt delivered into the drum.

Asphalt proportioning is accomplished by establishing the necessary rate of asphalt delivery in gallons per minute to match the aggregate delivery in tons of dry aggregate per hour. The asphalt delivery rate is adjusted to correspond to the weight measurement of the aggregate prosing over the belt scale.

Drum-Mix Operation

The mixer is the heart of a drum-mix plant. Compared to a conventional batch plant rotary dryer, the mixer is similar in design and construction except that the drum-mixer can be divided into two sections: (1) a primary or radiation zone and (2) a secondary or convention/coating zone (fig. 8-18).

Aggregates enter the primary zone where heat from the burner dries and heats it. Then the aggregate moves to the secondary zone where asphalt is added, and aggregates and asphalt are thoroughly blended. Continued drying also occurs in the secondary zone. The mixture of hot asphalt and moisture released from the aggregate produces a foaming mass that traps the fine material (dust) and aids in the coating of the larger particles.

Drum-mixers are equipped with flights to direct the aggregate flow and spread the aggregates into a veil

across the cross section of the drum. The aggregates must not only rotate with the revolving motion of the drum but must also spread out sufficiently to make heating and drying of all particles quick and efficient.

The spiral flights are located at the charging (burner) end of the drum-mixer and direct wet aggregates into the drum in such a manner as to attain uniform drum loading. Tapered lifting flights pick up the aggregates and drop them in an even veil through the burner flame.

Burner Operation

The burner inside the drum-mixer provides the heat necessary to heat and dry the aggregates used in the final mixture. The burner provides this heat by burning fuel oil, gas, or both.

When oil is burned, a low-pressure air draft is used to atomize the fuel oil for burning. Depending on the type of fuel used for the burners, the fuel feed and air blower must be balanced to ensure that the proper proportions of fuel and air are being introduced into the burner to ensure efficient combustion. Lack of balance can lead to incomplete burning of the fuel. Especially, when fuel oil or diesel fuel is used, this can leave an oily coating on the aggregate particles. An imbalance between the fuel feed and air flow can be adjusted by either decreasing the fuel rate or increasing the blower or draft air.

Surge Silo

The drum-mix plant produces a continuous flow of fresh asphalt hot mix and has a surge silo for temporary storage of the hot-mix material. The surge silo is also used for controlled loading of trucks. A weight system is normally connected to the holding bin of the silo to monitor the amount of hot mix loaded into each truck. Weight measurements are normally recorded by the weight system control panel.

BITUMINOUS SURFACING MATERIALS

Bituminous materials are tremendously important in the construction of roads and airfields for both military and civilian use. A basic knowledge of these bituminous materials, their origin, composition, types, and grades are essential for an understanding of their use in construction.

Bituminous surfaces are composed of compacted aggregate and bitumen (binder). The aggregate

transmits the load from the surface to the subgrade, takes the abrasive wear of the traffic, and provides a nonskid surface. The binder binds the aggregate together, thus preventing the displacement and loss of the aggregate. The binder also provides a waterproof cover for the base that keeps surface water from seeping into and weakening the material.

Bituminous surfaces are particularly adaptable to stage construction. Additional courses can be added to existing pavements to provide further reinforcement when loads or traffic density increases. The flexibility of bituminous surfaces permits slight adjustment caused by settlement of the subgrade without detrimental effect. Properly designed bituminous wearing surfaces, when compared with concrete, are less affected by temperature strains. The surfaces resist wear, weathering, and deterioration from aging with only minimal maintenance.

Bituminous materials are highly versatile and serve admirably in temporary, expedient, and light traffic situations where concrete is not justifiable. It is equally true that thicker bituminous pavement designed for heavy and continuing duty is fully comparable to concrete designed for heavy volumes of traffic or heavy wheel loads; however, bituminous wearing surfaces lack appreciable bearing action to carry wheel loads over weak spots in the subbase. For this reason, the subgrade must have an adequate, uniform bearing strength and the base course must have adequate thickness, bearing capacity, and cohesion.

TYPES AND GRADES OF ASPHALT

Asphalt is a natural or man-made by-product of petroleum distillation. Natural asphalt is found in nature as either lake (or pit) asphalt or rock asphalt. The common bituminous surfacing materials are asphalt cements, asphalt cutbacks, asphalt emulsions, road tars, and road tar cutbacks. For identification purposes, these materials are divided into three classes: asphalt bitumens, emulsions, and tars. The classification of these materials is based on the extent to which they dissolve in a distillate of petroleum or coal. Asphalt cements and asphalt cutbacks are asphalt bitumens (or asphalts). Road tars and road tar cutbacks are tars.

Asphalt Cements

Asphalt cements are solid products of petroleum refining (fig. 8-19). An asphalt cement is designated by the letter symbol AC, followed by the penetration grade that represents its relative hardness. The numbers range

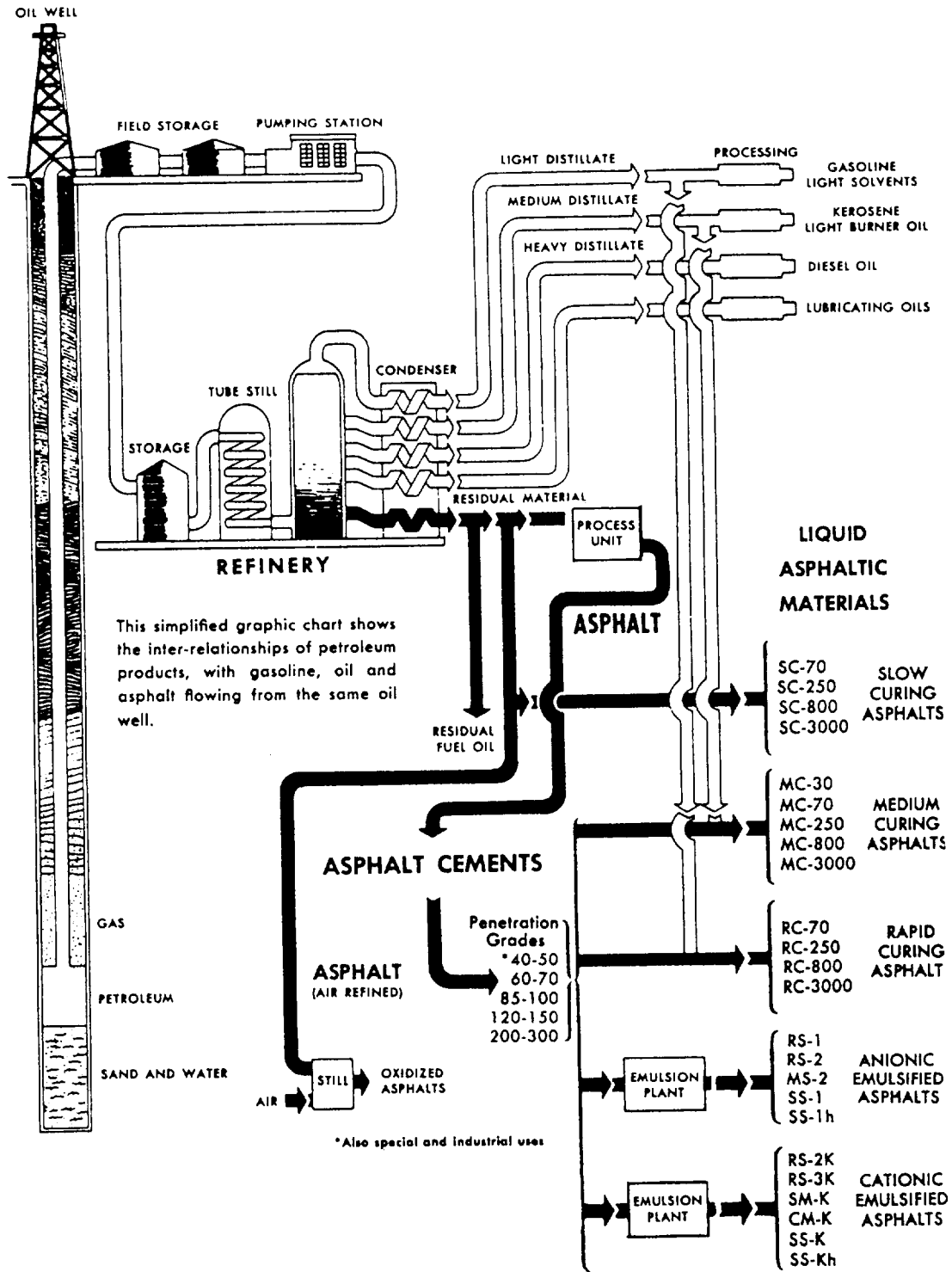

Figure 8-19.-Petroleum asphalt flow chart.

Table 8-2.-Penetration Grade and AP Number of Asphalt Cement

Penetration grade	AP No.	Relative consistency
40-50	7	Hard
60-70	5	
85-100	3	
120-150	1	Medium
200-300	00	
		Soft

Table 8-3.-Asphalt Cutback Composition (Expressed in Percent of Total Volume)

Type	Components		Grades				
		Solvent	30	70	250	800	3,000
Rapid curing RC	Asphalt cement	-----	---	65	75	83	87
		Gasoline or naphtha -----	---	35	25	17	13
Medium curing MC	Asphalt cement	-----	54	64	74	82	86
		Kerosene -----	46	36	26	18	14
Slow curing SC	Asphalt cement	-----	---	50	60	70	80
		Fuel Oil -----	---	50	40	30	20

from 40 (hard) to 300 (soft) (table 8-2). The number is derived from a penetration test that is the distance that a standard needle penetrates the asphalt cement under a standard loading weight, in a given time, under known temperature conditions.

All asphalt cements are solid or semisolid at room temperature (77°F) and must be converted to a fluid for mixing with aggregate or for spraying. Asphalt cement must be heated to a temperature ranging from 250°F to 350°F, depending upon the grade of the asphalt cement.

The various penetration grades of asphalt cement are suitable for different uses, such as plant mixes, penetration macadam, and surface treatment. Soft penetration grades of asphalt cement are preferred for use in cold climates, medium grades in moderate climates, and hard grades in warm climates.

Asphalt Cutbacks

The special equipment needed to heat asphalt cements is not always available. Since asphalt must be

in a fluid condition to spray or to mix with an aggregate, the solid asphalt cement would not be suitable. Asphalt cement (AC) can be made fluid by adding solvents called *Cutterstock* or *Flux Oil*. Cutterstock may be any one of the more volatile petroleum distillate products. The resulting combination is called *Asphalt Cutback*. Exposure to air causes the petroleum distillate to evaporate and leave the asphalt cement to perform its function.

The rate of evaporation determines the type of asphalt cutback that is in the mixture. Gasoline or naphtha (highly volatile) will produce a rapid-cure cutback (RC) with a curing time of 4 to 8 hours; kerosene (medium volatility) will produce a medium-curing cutback (MC) with a curing time of 12 to 24 hours; and a fuel oil (low volatility) will produce a slow-curing cutback (SC) with a curing time of 48 to 60 hours. Table 8-3 shows the percentage of components by grade for the three types of asphalt cutbacks.

Table 8-4.-Asphalt Emulsions According to Their Electric Charge

Kind	Type	Viscosity Grade	Mixing Ability
Anionic	RS	RS-1, RS-2	Spraying
	MS	MS-2	Mixing and spraying
	SS	SS-1, SS-1h	Mixing and spraying
Cationic	RS-C	RS-2C, RS-3C	Spraying
	MS-C	SM-C	Mixing (sand) and spraying
	MS-C	CM-C	Mixing (coarse aggregate) and spraying
	SS-C	SS-C, SS-Ch	Mixing and spraying

Note: C – denotes cationic emulsion.
h – denotes a lower penetration grade of asphalt cement.

Grades of Asphalt Cutbacks

When a great amount of cutterstock is added to a given amount of asphalt cement, a very thin liquid results. Viscosity grade is a measure of the relative consistency of an asphalt bitumen after cutterstock is added to a fixed amount of it. The grade is designated by a number that corresponds to the lower limit of the viscosity of asphalt cutback as determined by a standard test. The upper limit of viscosity is defined as twice the lower limit.

The viscosity grades of RC, MC, and SC are 70 (70-140), 250 (250-500), 800 (800-1,600), and 3,000 (3,000-6,000). The numbers in parenthesis are the lower and upper limits of viscosity. In addition, MC has a grade 30(30-60). The grade ranges are 30 (most fluid) to 3,000 (least fluid).

Uses of Asphalt Cutbacks

Different types and grades of asphalt cutbacks are used to meet various climate conditions for different types of pavement. Asphalt cutbacks are usually used for prime/tackcoats and for bituminous surface treatments. The prevailing atmospheric temperatures existing during construction projects are a major factor in selecting the grade of asphalt cutback. The heavier grades are preferred for use in warm weather; the lighter grades in cool weather. When the preferred grade of a given type of asphalt cutback is not available, a comparable grade of another type may be substituted; for example, RC-800 maybe used instead of MC-800, or RC-70 instead of MC-70, without seriously affecting the finished pavement.

Light grades of asphalt cutback maybe produced in the field by adding solvents to asphalt cutback. The composition of asphalt cutbacks, expressed in percent of total volume, is shown in table 8-3.

Asphalt Emulsions

An asphalt emulsion is a nonflammable liquid substance, composed of asphalt cement, water, and an emulsifier mixed together to produce a liquid material. Emulsions are environmentally friendly, have the same basic uses as cutbacks and are becoming more commonly used in the field. Asphalt and water will not mix; therefore, a chemical agent called an “emulsifying agent” must be added. The emulsifying agent keeps the asphalt cement suspended in the water and controls certain physical properties of the emulsion. Common emulsifying agents are soaps, animal blood chemicals, and certain specified colloidal clays in dust. When emulsion is applied to a surface, the water and asphalt cement break (separate), leaving a thin film of asphalt cement.

The speed of separation, referred to as *setting rate*, is the basis for designating an asphalt emulsion. The setting rates are rapid, medium, and slow. The letter symbols for these rates are RS, MS, and SS, respectively.

Asphalt emulsions are classified into two types: those that are negatively charged and those that are positively charged (table 8-4). Emulsified asphalts may be of either the anionic electro (negatively) charged asphalt globules or cationic electro (positive) charged asphalt globules. The asphalt emulsions are graded on the basis of viscosity and grouped according to their use.

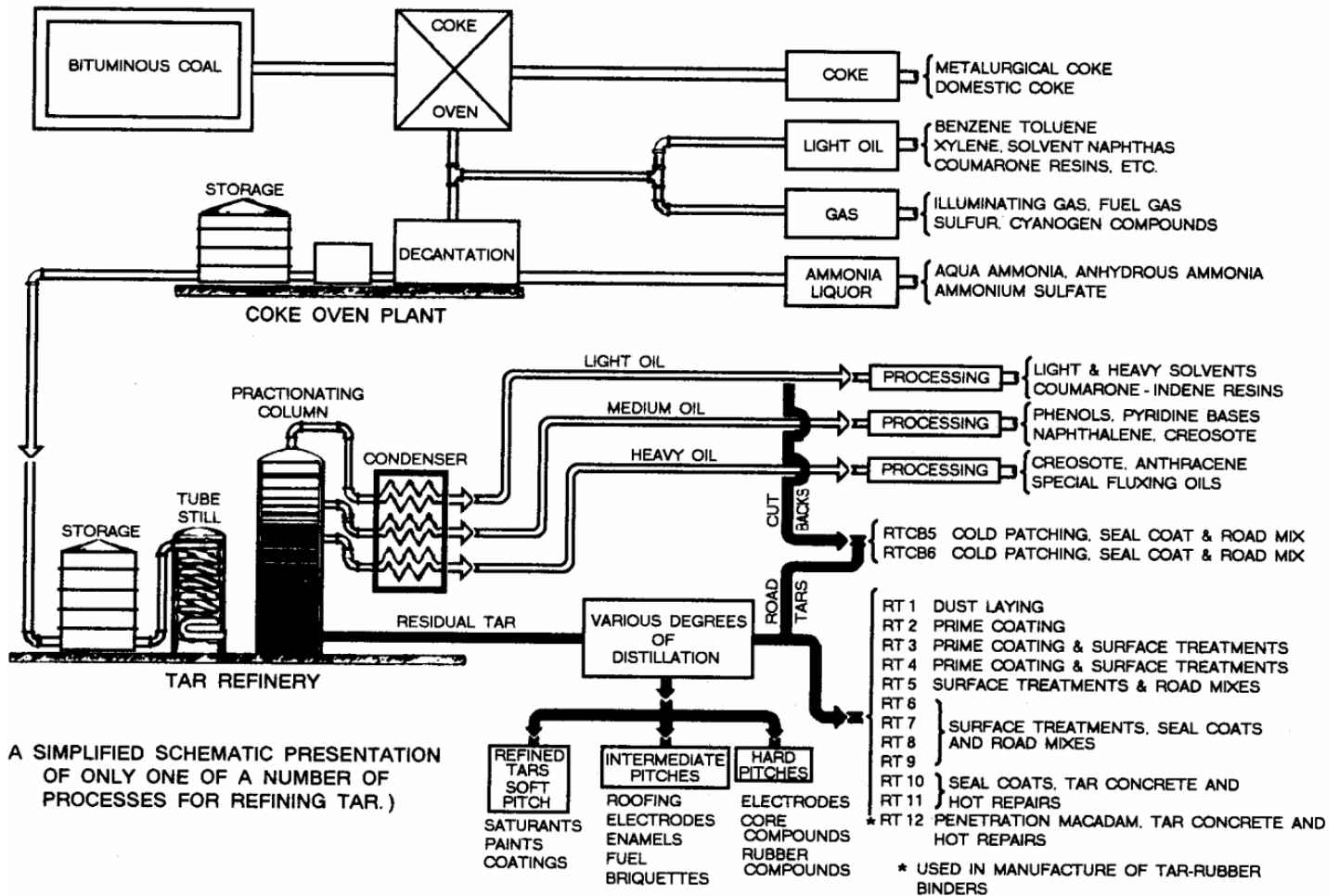

Figure 8-20.—Tars obtained from distillation of bituminous coal.

The viscosity grades range from 1 (least fluid) to 3 (most fluid).

Use of Asphalt Emulsions

Emulsions are used for surface treatment, road and plant mixes, and crack and joint filling. The mixing grades can be mixed unheated with damp aggregate. They are preferred over asphalt cutback when the aggregate is very damp. Cationic emulsions coat damp aggregate better than anionic emulsion.

Recommended use of emulsions depends on setting rate and mixing ability. At water-freezing temperatures, asphalt emulsions do not mix well since the emulsion will separate from the water. Also, emulsions have a relatively short shelf life and tend to break while still in their unopen drums.

Tars

Tars are obtained from the distillation of bituminous coal (fig. 8-20) and are seldom used in the NCF. A road tar is designated by the symbol RT and is manufactured in 12 grades of viscosity (table 8-5). RT-1, RT-2, and RT-3 are *PRIMING OIL*. RT-4 through RT-7 are called *COLD TARS* because they are fluid enough to be mixed and applied at relatively low temperatures. RT-8 through RT-12 are called *HOT TARS* because they are solid enough to require high temperatures for mixing and applying.

The symbol RTCB refers to *ROAD TAR CUTBACK*. RTCBs are manufactured only in viscosity grades 5 and 6. Coal distillate, such as benzene or a solution of naphthalene in benzol, may be used to cutback the heaviest grades of road tar to produce both grades of road tar cutbacks. The viscosity grades of road tars and road tar cutbacks can be compared to the

Table 8-5.-Viscosity Grades at Room Temperature

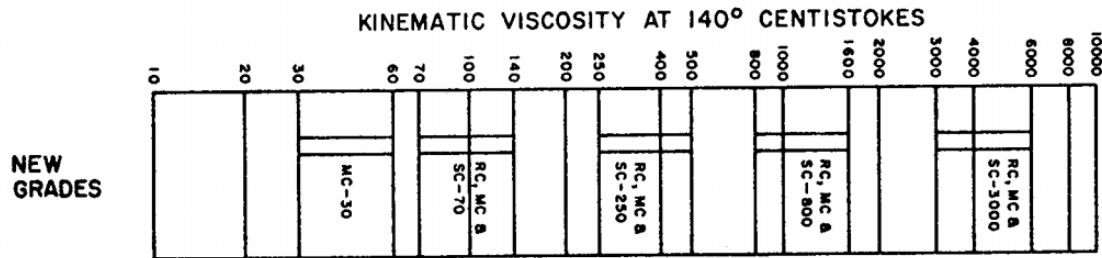
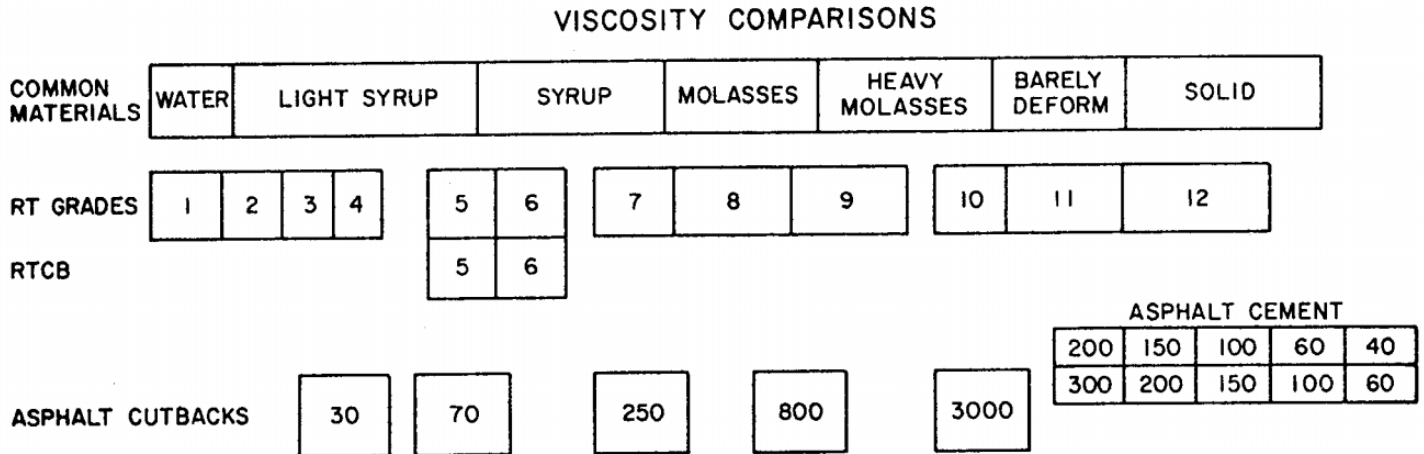

viscosity grades of asphalt cutbacks and asphalt cements by means of table 8-5.

Use of Tars

Tars are suitable for use on areas where asphalt is unsuitable. A good example is an airfield where petroleum distillates are likely to be spilled. Tars do not strip easily from aggregate in the presence of water and is preferred as a prime coat. Tars penetrate more deeply into the base course than will asphalt of the same viscosity and curing rate.

Cold-tar mixes are used for road mix and patching. Hot-tar mixes are used for plant mix, surface treatment, crack fillers, and similar uses. Since tars become soft at high temperatures and brittle at low temperatures, the heavier grades are preferred for use in warm weather and the lighter grades in cool weather.

Road tar cutbacks are used for patching mixes; however, an open flame must NOT be used near storage tanks and drums of road tar cutbacks because they are flammable.

FIELD IDENTIFICATION OF BITUMINOUS MATERIALS

Identifying bituminous materials can be a problem. Stockpiled bituminous materials that are unmarked or improperly marked can cause unnecessary delays in construction operations. Fairly accurate identification is necessary to decide on the type of construction that the materials can be used for, the method of construction to be used, the type and quantity of equipment needed, and the applicable safety regulations to be observed. Some of the tests used in the field to identify bituminous materials as asphalt cement, asphalt cutback, asphalt emulsion, road tar, or road tar cutback are as follows:

- Solubility
- Pour
- Smear
- Heat-Odor
- Penetration
- Stone coating

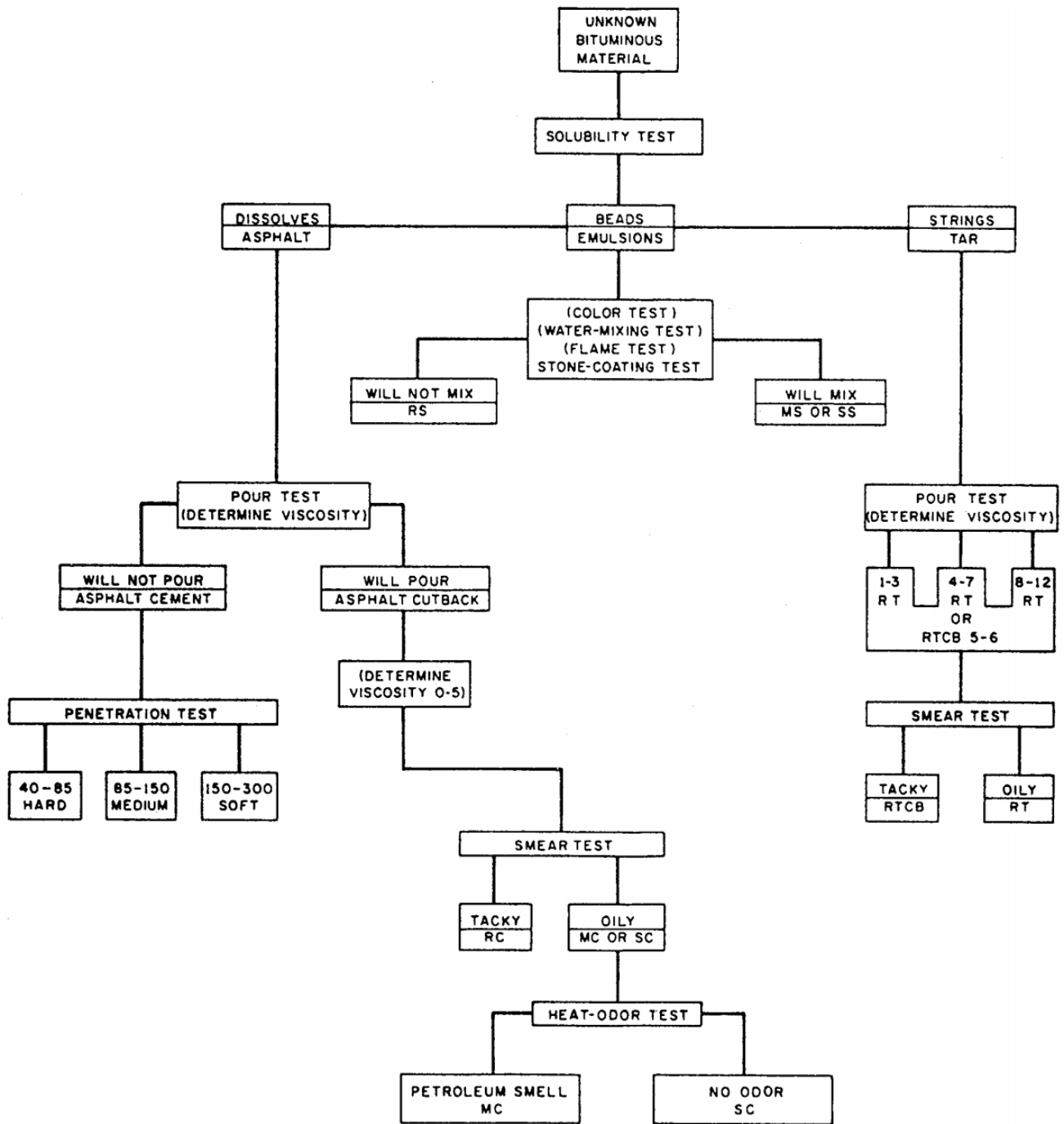

Figure 8-21.—Field identification of unknown bituminous materials.

Field identification of bituminous materials is summarized in figure 8-21.

Solubility Test

The solubility test consists of taking a small amount of the unknown bituminous material, enough to cover the head of a nail if a solid, or few drops of a liquid material and attempting to dissolve the material by stirring it in a petroleum distillate; gasoline, kerosene,

diesel fuel, and so forth. If the material is an asphalt, it will mix uniformly with the distillate. Tars, however, will form a stringy undissolved mass. Emulsions, in addition to other distinguishing tests, may also be identified in the solubility test since they will form undissolved balls or beads of the emulsion at the bottom of the container of petroleum distillate. The solubility test provides a positive method of identification (fig. 8-22).

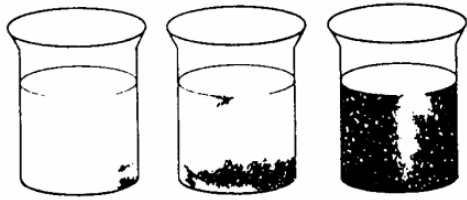

FROM LEFT TO RIGHT: KEROSENE, KEROSENE PLUS TAR, KEROSENE PLUS ASPHALT CEMENT OR ASPHALT CUTBACK.

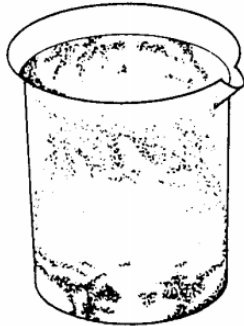

BEADS FORMED BY ASPHALT EMULSION IN KEROSENE.

Figure 8-22.—Solubility test for asphalt, tar, and emulsion.

Pour Test

When you perform the volatility test and the bituminous material dissolves, an asphalt product—*asphalt cement* or *asphalt cutback*—is present. At room temperature (77 F) asphalt cements are solids, and asphalt cutbacks are fluids. With these facts in mind, you may run a second test, a pour test, to determine whether a sample is an asphalt cement or an asphalt cutback.

In the pour test, an attempt is made to pour the material from a small container. Asphalt cements are solids and will not pour. Asphalt cutbacks are fluids at 77 F and will pour (fig. 8-23).

A pour test is also used to identify the 12 viscosity grades of tar. Viscosity grades of road tar are comparable to the viscosity grades of asphalt cutbacks and asphalt cement (table 8-5). RT-1, the most fluid, is similar in viscosity to the grade 30 of the rapid-curing, medium-curing, and slow-curing types of asphalt cutbacks. RT-8 is similar to grade 800 asphalt cutback. RT-12 has the approximate consistency of asphalt cement of 200-300 penetration.

Road tar grades 4, 5, and 7, which are identical in appearance to road tar cutback grades 5 and 6 may be distinguished through a smear test. Like asphalt

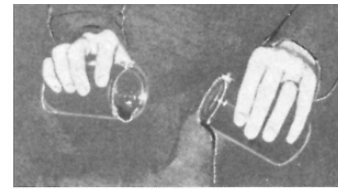

ASPHALT CEMENT ON LEFT. ASPHALT CUTBACK ON RIGHT.

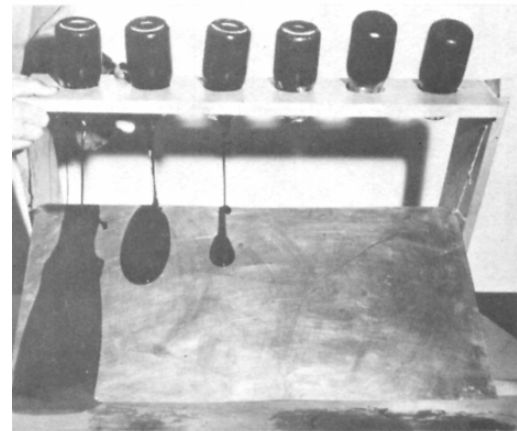

LEFT TO RIGHT: ASPHALT CUTBACKS GRADE 30, 70, 250, 800, AND 3,000 THREE SECONDS AFTER TIPPING FULL JARS.

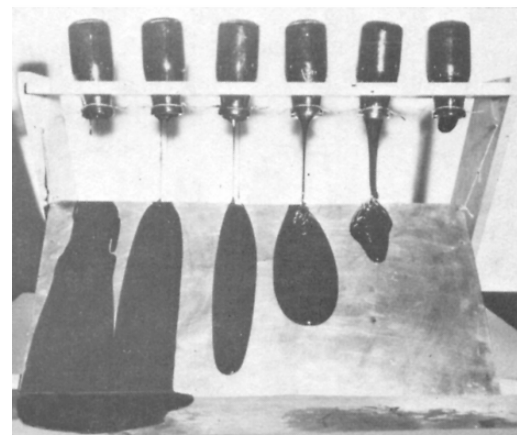

THIRTEEN SECONDS AFTER TIPPING FULL JARS.

Figure 8-23.—Pour test for asphalt and cutbacks.

143.179

cutbacks, road tar cutbacks cure rapidly since they are thinned with highly volatile materials that evaporate quickly and leave a sticky substance within a 10-minute period. On the other hand, because the fluid coal oil in road tars evaporates slowly, road tars will remain at the same consistency at the end of an identical period.

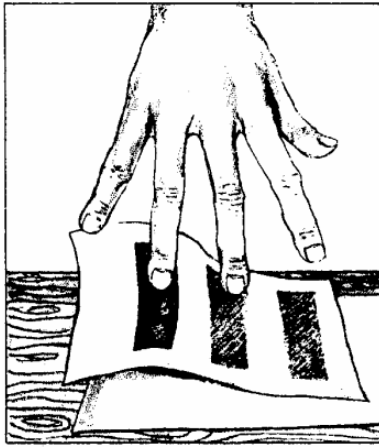

LEFT TO RIGHT, RC, MC, AND SC
AFTER 10 SECONDS, ONLY RC
IS STICKEY.

Figure 8-24.—Smear test of asphalt cutback.

Smear Test

The smear test is used to separate an RC from an MC or SC. The test is primarily based on the fact that RCs are cutback with a highly volatile material (naphtha or gasoline). You can determine whether a sample is an RC or not by smearing some of the sample in a thin layer on a nonabsorbent surface, such as a piece of glazed paper. The volatile substance evaporates within a few minutes and the surface becomes so tacky that when touched, the specimen, paper and all, sticks to your fingers and can be lifted into the air (fig. 8-24).

Checking the reverse side of the paper, you will find that the RC did not penetrate through the paper as MCs or SCs do. MCs and SCs on smear tests remain fluid and oily for time periods that vary from hours to days, depending on the type and grade of material. If an 800 or 3,000 grade MC or SC is present, they may become sticky in a few minutes since there is such a small amount of cutterstock in them. When such a viscous grade is present, it is well to confirm the identification of the sample by a *prolonged smear test*. Generally, the MCs and SCs will penetrate through the paper while the RCs will not. You can determine this by observing the back side of the paper.

In a prolonged smear test, a thin smear is made on nonabsorbent paper and allowed to cure completely. If the viscous cutback is all RC-3000, it will cure completely in about 3 hours. When the spot has cured completely (the cutterstock has almost all evaporated), the smear will be almost pure asphalt cement (AC) and will be hard and no longer sticky. If the viscous sample were an MC or SC-800 or 3,000, the spot would still be

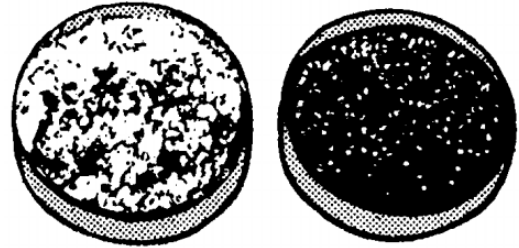

LEFT: DAMP SAND PLUS RS

RIGHT: DAMP SAND PLUS MS OR SS

Figure 8-25.—Stone-coating test for emulsions.

uncured and, therefore, very sticky, even after 24 hours, while the RC smear will have become a hard, glazed spot.

Heat-Odor Test

A heat-odor test is used to distinguish between medium-curing and slow-curing asphalt cutback by identifying the cutter stock as kerosene, fuel oil, or diesel oil. A sample of the material is heated in a closed container to retain the vapors. (CARE MUST BE TAKEN TO AVOID THE USE OF TOO MUCH HEAT). Medium-curing asphalt cutback will have a strong odor of kerosene. Slow-curing asphalt cutback will lack the kerosene odor, but a faint odor of motor oil may be present.

Field Penetration Test

The field penetration test is performed to determine the approximate hardness of the asphalt, not to pinpoint the exact penetration number for it. To determine if the number falls in the hard, medium, or soft group is sufficient.

To perform this test, attempt to push a sharpened pencil or nail into the container of asphalt (at about 77°F), using a firm strong pressure of approximately 10 pounds. If only a slight penetration is made with considerable difficulty, a hard asphalt cement is present. When the penetration is made slowly but without great difficulty, a medium asphalt cement is present. If the penetration is made with ease, the asphalt cement is a high penetration scale (a soft AC).

Stone-Coating Test

When a material has been tested and found to be an emulsion, the stone-coating test is performed (fig. 8-25). This test is conducted to determine if the emulsion is a



LEFT: WATER PLUS TAR OR ASPHALT CUTBACK

RIGHT: WATER PLUS ASPHALT EMULSION

Figure 8-26.-Water-mixing test for emulsions.

rapid setting emulsion termed a *nonmixing* grade or a medium- or slow-setting emulsion termed as mixing grade emulsion. To know which type is present is important because the applications of the mixing and nonmixing types vary greatly. The test performed to distinguish between these two types of emulsions is the stone-coating test. This test consists of taking a handful of damp sand and adding to the sand a small amount of emulsion (estimate about 6 to 8 percent by weight) and attempting to mix the two materials. Care should be exercised not to add so much emulsion that the sand becomes saturated.

A rapid-setting emulsion will "break" so quickly it will not be possible to mix it with sand. It breaks immediately, gumming up the mixing spoon and the aggregate with asphalt cement; otherwise, if the unknown sample is a medium- or slow-setting emulsion when added to the damp sand, it will mix easily and coat all the particles completely as well as the mixing spoon with a uniform coating of asphalt. Identification of an emulsion merely as a mixing or nonmixing type is sufficient for field conditions. The difference in viscosity is unimportant because there are so few grades. No distinction is necessary between medium- and slow-setting emulsions since both are mixing types used largely for the same purpose.

Another test for emulsions is the *WATER-MIXING TEST* (fig. 8-26). Because emulsions are made with water, more water may be added to emulsions without disturbing the uniformity of the liquid. None of the other bituminous materials will dissolve in water.

A *FLAME TEST* can also be used in testing asphalt emulsions. A cloth saturated with asphalt emulsion will smolder but will not burn or burst into flame. Other bituminous materials are combustible.

Laboratory Test of Bituminous Materials

In addition to the field tests, various tests are performed on bituminous materials in the laboratory. These tests usually are made for the purpose of checking compliance with the established specifications; however, laboratory tests may also be made to identify the material beyond field identification, to furnish information for mix design, or to establish safe handling procedures.

Bituminous materials are produced to meet the specification established by the federal government, the American Association of State Highway Officials (AASHO), and the American Society for Testing Materials (ASTM). These specifications define the extreme limits permitted in the manufacture of the material and assure the user that the material will possess definite characteristics and fulfill the project requirements. Consult with the EAs for the proper specifications required.

ESTIMATION OF MATERIALS

Many different combinations of materials are used on bituminous surfaces. Before a bituminous surface is placed, the surface to be covered normally requires the placing of a preliminary treatment: a prime or a tack coat.

Prime Coat

Prime coats are placed on a dirt or gravel surface. The purpose of priming is to waterproof and dustproof the surface, plug capillary voids, and coat and bond loose particles. A prime coat also hardens or toughens the surface, promotes adhesion between the existing surface and the new surface, and penetrates the surface. The priming material may be one of the following:

- A low-viscosity tar, such as RT-2, RT-3, or RT-4
- A low-viscosity asphalt, such as MC-30, -70, -250, or SC-70, -250, -800
- A diluted asphalt emulsion

Bituminous materials used for the prime coat should be applied in quantities known as the rate of application (ROA) of not less than 0.2 gallon or more than 0.5 gallon per square yard. Normally, the construction project specifications denote the ROA for the prime coat application; however, when the ROA is not included in the project specifications, the NCF uses an ROA of .3 for planning purposes.

To estimate the amount of bitumen required for the prime coat, multiply the area to be treated by the rate of application. Under certain conditions, the estimate should include sufficient bitumen for an additional width of 1 foot on each side of the surface course to be constructed on the primed base.

The formulas for a prime coat estimate are as follows:

For computing gallons:

Step 1:

Gallons of Prime Coat Required

$$= \frac{ROA \times L \times (W + 2)}{9}$$

Step 2:

Gallons Needed for Waste

$$= \text{Gallons of Prime Coat} \times WF (.05 \text{ or } .10)$$

Step 3:

Total Gallons Required

$$= \text{Gallons of Prime Coat} + \text{Waste Gallons}$$

For computing drums:

Step 1:

Drums of Prime Coat Required

$$= \frac{ROA \times L \times (W + 2)}{9 \times 53}$$

Step 2:

Drums Needed for Waste

$$= \text{Drums of Prime Coat} \times WF (.05 \text{ or } .10)$$

Step 3:

Total Drums Required

$$= \text{Drums of Prime Coat} + \text{Waste Drums}$$

Where:

G = gallons of bitumen primer

D = drums of bitumen primer

L = length of treated section in feet
(5,280 feet equal one mile)

W = width of treated surface in feet

ROA = rate of application of bitumen in gallons per square yard

WF = waste factor of bitumen = 5% at .05 or 10% at .10. The value of the factor depends on the experience of the asphalt distributor truck crew

9 = square feet per yard conversion factor

53 = gallons per drum

Example: The specifications and other data for a prime coat project are as follows:

L = 3 miles = 3 × 5,280 feet = 15,840 feet

W = 24 feet

ROA = 0.3 gal/sq yd

WF = 5 percent (or) .05

Find the number of gallons of bitumen (G) necessary to do this project.

Solution:

Gallons required for the project without waste considered:

$$\text{Gallons} = \frac{.3 \times 15,840 \times (24 + 2)}{9} = \frac{123,552}{9} = 13,728 \text{ gallons}$$

Compute waste factor:

$$13,728 \text{ Gallons} \times WF \text{ of } .05 = 686.4 \text{ Gallons}$$

Total gallons required for the project:

$$686.4 \text{ Gallons} + 13,728 \text{ Gallons} = 14,414.4 \text{ Gallons}$$

Always round your answer to the next higher number. In this case, 14,414.4 is rounded to 14,415 gallons.

Tack Coat

A tack coat is a coating of asphalt on an existing paved surface that provides a bond between the existing surface and the new surface. The two essential properties of a tack coat are as follows: (1) it must be very thin and (2) it must uniformly cover the entire surface of the area. When tack

coats are too heavy, they leave a surplus of asphalt that bleeds into the overlying course. A thin tack coat does no harm to the pavement and properly bonds the courses.

Tack coat materials may be as follows: (1) a road tar, grade RTCB 5-6, RT-6, 7, 8, 9, 10, or 11; (2) an asphalt cutback, such as RC-250 or -803; (3) a diluted emulsion; or (4) an asphalt cement, such as an AP-3 (85-100 penetration) or AP-1 (120-150 penetration).

Bituminous materials for the tack coat should be applied in quantities not less than 0.05 or more than 0.25 gallon per square yard. The exact quantity depends upon the condition of the surface to be tacked. Normally, the construction project specification denotes the ROA for the tack coat application; however, when the ROA is not included in the project specifications, the NCF uses an ROA of .15 for planning and estimating purposes.

The procedure for estimating the bitumen required for a tack coat is similar to that described for a prime coat except that the tack coat is applied only over the proposed width of the pavement.

The formulas for a tack coat estimates are as follows:

For computing gallons:

Step 1:

$$\text{Gallons of Tack Coat Needed} = \frac{ROA \times L \times W}{9}$$

Step 2:

Gallons Needed for Waste

$$= \text{Gallons of Tack Coat} \times WF (.05 \text{ or } .10)$$

Step 3:

Total Gallons Required

$$= \text{Gallons of Tack Coat} + \text{Waste Gallons}$$

For drums, the formulas are as follows:

$$\text{Drums of Tack Coat} = \frac{ROA \times L \times W}{9 \times 53}$$

Drums Needed for Waste

$$= \text{Gallons of Tack Coat} \times WF (.05 \text{ or } .10)$$

Total Drums Required

$$= \text{Drums of Tack Coat} + \text{Waste Drums}$$

G = gallons of bitumen primer

D = drums of bitumen primer

L = length of treated section in feet

W = width of treated surface in feet

ROA = rate of application of bitumen in gallons per square yard

WF = Waste factor of bitumen = 5% at .05 or 10% at .10. This will depend on the experience of the distributor truck crew

9 = square feet per yard conversion factor

53 = gallons per drum

Example: The specifications and other data for a tack coat project are as follows:

$$L = 2.7 \text{ miles} = 2.7 \times 5,280 = 14,256 \text{ feet}$$

$$W = 24 \text{ feet}$$

$$ROA = 0.05 \text{ gal/sq yd}$$

$$WF = 5 \text{ percent or } .05$$

Calculate the number of drums of bitumen needed to accomplish this project.

Solution:

Step 1:

$$\begin{aligned} \text{Drums} &= \frac{.05 \times 14,256 \times 24}{9 \times 53} \\ &= \frac{17,107.2}{477} = 35.86 \text{ Drums} \end{aligned}$$

Step 2:

$$\text{Waste} = 35.86 \text{ Drums} \times WF \text{ of } .05 = 1.79 \text{ Drums}$$

Step 3:

$$\text{Total Drums Needed} = 1.79 + 35.86 \times 37.65 \text{ Drums}$$

This project requires 38 drums of bitumen.

Surface Treatment

Bituminous materials and aggregate are combined in various proportions to obtain the most satisfactory surface for a given situation. Accurate estimates are required to avoid production delays because of inadequate supplies. You also want to avoid oversupply and waste of materials.

The formulas for estimating supplies for a single-surface treatment are as follows:

For computing pounds:

Step 1:

$$(\text{Pounds of Material Required}) P = \frac{L \times W \times ROAA}{9}$$

Step 2:

Pounds Needed for Waste

$$= \text{Pounds of Material} \times WF (.05 \text{ or } .10)$$

Step 3:

Total Pounds Required

$$= \text{Pounds of Material} + \text{Pounds for Waste}$$

For computing tons:

Step 1:

$$(\text{Tons of Material Needed}) T = \frac{L \times W \times ROAB}{18,000}$$

Step 2:

$$\text{Tons of Waste} = \text{Tons of Material} \times WF (.05 \text{ or } .10)$$

Step 3:

Total Tons of Material Required

$$= \text{Tons of Material Required} + \text{Tons Allowed for Waste}$$

The formula for gallons of bitumen required is as follows:

Step 1:

(Gallons of Bitumen Needed)

$$G = \frac{L \times W \times (ROAA \times ROAB)}{9}$$

Step 2:

Gallons for Waste

$$= \text{Gallons of Bitumen} \times WF (.05 \text{ or } .10)$$

Step 3:

Total Gallons Bitumen Required

$$= \text{Gallons of Bitumen for Project}$$

$$+ \text{Gallons Allowed for Waste}$$

Where:

P = weight of aggregate in pounds

T = weight of aggregate in tons

L = weight of treated surface in feet

W = width of treated surface in feet

ROAA = rate of application of aggregate in pounds per sq/yd

ROAB = rate of application of binder per pounds of aggregate per sq/yd.

WF = waste factor for bitumen 5% or .05 or 10% at .10

9 = square feet per square yard conversion factor

18,000 = 2,000 (pounds per ton) \times 9 (square feet per square yard)

The materials for a multiple-surface treatment are determined by the same method as above except the application rate of the binder and the aggregate, and the size of the aggregate for the second lift is one half of that of the first lift.

Example: A test strip with an area of 100 square yards was used to determine the quantities for a single-surface treatment. Careful control was made of materials. A check of materials consumed showed that 1.50 tons of aggregate was used. Based on previous experience, an aggregate loss of 10 percent (0.10) and a bitumen loss of 5 percent (0.05) are expected. Find the tons of aggregate and gallons of bitumen necessary to make a double-surface treatment on a road 24 feet wide and 10 miles long.

Solution:

(1) Aggregate 1st lift:

$$ROAA = \frac{1.50 \text{ tons} \times 2000 \text{ lb/ton}}{100 \text{ sq yd}} = 30 \text{ lb/sq yd}$$

$$T = \frac{(10 \text{ miles} \times 5,280 \text{ feet}) \times 24(W) \times 30 (ROAA)}{18,000}$$

$$+ \frac{380,160,000}{18,000} = 2,112 \text{ tons}$$

$$\text{Waste} = 2112 \text{ tons} \times .10 = 211.2 \text{ tons}$$

$$211.2 \text{ tons waste} + 2,112 \text{ tons} = 2323.2 \text{ tons}$$

A total of 2,324 tons of aggregate are required.

Aggregate 2nd lift:

NOTE: 15 = 1/2 of first lift

$$T = \frac{(10 \text{ miles} \times 5,280 \text{ feet}) \times 24(W) \times 15 (ROAA)}{18,000}$$

$$= \frac{19,008,000}{18,000} = 1,056 \text{ tons}$$

$$\text{Waste} = 1,056 \text{ tons} \times .10 = 105.6 \text{ tons}$$

$$105.6 \text{ tons waste} + 1,056 \text{ tons} = 1161.6 \text{ tons}$$

A total of 1,162 tons of aggregate are required.

(2) Bitumen 1st lift:

$$ROAB = 0.01 \text{ Gallon per lb of Aggregate per sq yd}$$

$$B = \frac{(10 \text{ miles} \times 5,280 \text{ ft.}) \times (24W) \times (.01 \times 30 \text{ ARA})}{9}$$

$$= \frac{380,160}{9} = 42,240 \text{ Gallons}$$

$$\text{Waste} = 42,240 \text{ Gallons} \times .05(WF) = 2,112 \text{ Gallons}$$

$$\text{Total Gallons} = 2112 + 42,240 = 44,352 \text{ Gallons}$$

Bitumen 2nd lift:

$$B = \frac{(10 \text{ miles} \times 5,280 \text{ feet}) \times 24(W) \times (15 \times 0.005)}{9}$$

$$= \frac{95,040}{9} = 10,560 \text{ Gallons}$$

$$\text{Waste} = 10,560 \text{ Gallons} \times .05(WF) = 528 \text{ Gallons}$$

$$\text{Total Gallons} = 528 + 10,560 = 11,088 \text{ Gallons}$$

Compute Bituminous Material

Several methods are used to calculate the amount of hot-mix material required for paving projects; however, when the weight of a hot-mix per square yard or cubic foot is not known, two equations are used in the NCF to compute the number of tons of asphalt required for a project. These equations are as follows:

Equation 1

$$\text{Tons of Asphalt} = \frac{L \times W \times D \times 146}{2000} = \text{Tons} \times (WF)$$

$$= \text{Percent of Tons} + \text{Tons} = \text{Tons Required}$$

Where:

L = length of project in feet

W = width of project in feet

D = depth or thickness of compacted mat. You must change inches into feet by dividing the number of inches by 12 (inches in 1 foot). For paver screed height, add 1/8 inch for each inch of the mat to be paved. (Example: for a 2-inch mat, two blocks of wood 2 1/4 inch thick will be required to set under the screed.) The blocks must be thicker than the finished compacted mat to allow for additional compaction by rollers

146 = This number represents the approximate weight of 1 cubic foot of compacted hot-mix asphalt. This number can vary from 140 to 160 pounds; however, 146 pounds equals the 110 pounds per square yard per 1-inch depth of asphalt used in the second equation for figuring tons require for asphalt. (See table 8-5.)

WF = Waste factor equals 5% or .05, or 10% or .10, depending on the experience of the screed operators and handwork required on the project

2,000 = 2,000 pounds is equal to one ton; therefore, you must divide the total weight of material by 2,000, giving tons required.

Table 8-6. Weight and Volume Relations for Various Types of Compacted Asphalt Pavement.

Note: Because of the considerable variations of specific gravity, gradation, and other characteristics of mineral aggregates, weight per unit volume of compacted asphalt pavement varies considerably. Exact weights per unit volume should be determined in the laboratory from samples taken from the pavement or prepared in the laboratory with the same materials as used in the field.	Pounds Per Cubic Foot	Pounds Per Cubic Yard	Pounds Per Square Yard Per 1 inch Depth	
		100	2700	75
	105	2835	79	
	110	2970	83	
	115	3105	86	
	120	3240	90	
	125	3375	94	
	130	3510	97	
	135	3645	101	
	140	3780	105	
	145	3915	109	
	150	4050	112	
	155	4185	116	
	160	4320	120	
	Range	Range	Range	Frequently Used for Preliminary Estimate
Macadam-A. I. Type I or Penetration Macadam	110-135	2970-3645	82-101	95
Open Graded-A.I. Type II	115-140	3105-3780	86-105	100
Coarse Graded-A.I. Type III	130-150	3510-4050	97-112	105
Dense Graded-A.I. Type IV	135-155	3645-4185	101-116	110
Fine Graded-A.I. Type V	130-150	3510-4050	97-112	105
Stone Sheet-A.I. Type VI	130-150	3510-4050	97-112	105
Sand Sheet-A.I. Type VII	120-140	3240-3780	90-105	100
Fine Sheet-A.I. Type VIII	120-140	3240-3780	90-105	100
Mixed-in-Place Macadam-A.I. Spec. RM-1	110-135	2970-3645	82-101	95
Mixed-in-Place Dense Graded-A.I. Spec. RM-2	110-135	2970-3645	82-101	95
Mixed-in-Place Sand Asphalt-A.I. Spec. RM-3	100-125	2700-3375	75-94	85

Equation 2

$$\text{Tons of Asphalt} = \frac{L \times W}{9}$$

$$= \text{Square Yards} \times \frac{110 \text{ Pounds Per 1" Mat}}{2000}$$

$$= \text{Tons} \times \text{WF} = \text{Percent of Tons} + \text{Tons} = \text{Tons Required}$$

Where:

L = Length of project in feet

110 = Pounds per square yard of asphalt per 1 inch depth. (Example: A 2-inch mat will equal 220 pounds per square yard.)

9 = To obtain square yards from square feet, divide by 9

2,000 = 2,000 pounds equal one ton; therefore, you must divide the total weight of material by 2,000, giving tons required.

WF = Waste factor equals 570 or .05, or 10% or .10, depending on the experience of the screed operators, and handwork required on the project.

Example: The specifications for a parking lot paving project are as follows:

L = 90 feet

W = 30 feet

D = 2 inches

WF = .10

Find the amount of asphalt required for this project.

Solution:

$$\text{Equation 1} = \frac{30 \text{ feet} \times 90 \text{ feet} \times .167 \times 146}{2000}$$

$$= \frac{65831.4}{2000} = 32.9$$

(32.9 is rounded off to 33)

$$WF = 33 \times .10 = 3.3$$

$$\text{Total Tons Required} = 3.3 + 33 = 36.3$$

(36.3 is rounded off to 37)

$$\text{Equation 2} = \frac{30 \text{ feet} \times 90 \text{ feet}}{9} = 300 \text{ square yards}$$

$$\frac{300 \text{ square yards} \times 220}{2000} = 33$$

$$WF = 33 \times .10 = 3.3$$

$$\text{Total Tons Required} = 33 + 3.3 = 36.3$$

Estimates for Asphalt Plants

The amount of materials comprising the plant mix can be best determined by a proportionate method. This is demonstrated by the following example:

Example: The required tonnage of plant mix for a project is 800 tons. The aggregate blend is 50/40/10 (percentage coarse aggregate/fine aggregate/mineral filler). The bitumen content is 6 percent. How many tons of each aggregate are required?

The job mix formula is as follows:

$$\frac{100 - OAC}{100} \times \text{Percent AGG}$$

= Adjusted Percent of AGG

OAC = Optimum Bituminous (Asphalt) Content

Solution:

Total aggregate percent by weight = $100 - 6 = 94$ percent, or 0.94.

Coarse/aggregate = 0.94×50 percent = 47.0 percent by weight of the total mix.

Fine aggregate = $.094 \times 40$ percent = 37.6 percent by weight of the total mix.

Mineral filler = 0.94×10 percent = 9.4 by weight of the total mix.

To convert to tons, multiply the required tonnage of plant mix by the percentage of each component of the mix. The results should be adjusted so that the sum of the tonnage of components is equal to the required tonnage of plant mix.

$$\text{Coarse aggregate} = 800 \times 0.470 = 376.0 \text{ tons}$$

$$\text{Fine aggregate} = 800 \times 0.376 = 300.8 \text{ tons}$$

$$\text{Mineral filler} = 800 \times 0.094 = 75.2 \text{ tons}$$

$$\text{Bitumen} = 800 \times 0.060 = 48.0 \text{ tons}$$

800 tons

(The bitumen weight was calculated as a check.)

Tons per hour

The equation used to compute the amount of asphalt that can be laid with a paver per hour is as follows:

$$\text{Tons per hour} = \frac{L \times W \times D \times 146}{2000} \times 60$$

Where:

L = Feet per minute. The NCF uses 11 feet per minute for planning purposes,

W = Width of the paver screed

D = Depth or thickness of compacted mat

146 = This number represents the approximate weight of 1 cubic foot of compacted hot-mix asphalt

60 = 60 minutes in one hour

2000 = There are 2,000 pounds in 1 ton

Example: The required tonnage of hot-mix asphalt for a project is 800 tons. The screed of the paver is set at 10 feet, and the depth of asphalt is 2 inches. Estimate the amount of asphalt that can be laid per hour.

Solution:

$$\frac{11 \times 10 \times .167 \times 146 \times 60}{2000} = \frac{160921.2}{2,000}$$

$$\frac{160921.2}{2,000} = 80.46 \text{ tons per hour}$$

By planning and estimating the amount of hot-mix asphalt that can be laid per hour, you are able to tell the asphalt plant exactly how much hot-mix asphalt is required to be delivered per hour and/or per day.

ASPHALT PLANT SAFETY

You must always be safety conscious and on the alert for potential dangers to personnel and property. Safety considerations cannot be overemphasized.

Coal distillate, such as benzene or naphthalene in benzol, are suspected carcinogens. Avoid all skin contact and do not inhale the vapors and gases from these distillates. Asphalt contains components suspected of causing cancer. Anyone handling asphalt must be trained on the health hazards.

Dust is particularly hazardous because of its threat to your lungs and eyes. Additionally, dust contributes greatly to poor visibility when trucks, front-end loaders, or other equipment are being used around the stockpiles or cold bins. Reduced visibility in work traffic is a prime cause of accidents.

Noise can be a double hazard. Noise is not only harmful to your hearing but also distracts your attention from moving equipment or other dangers.

Moving belts transporting aggregates should be a constant concern, as should belts to motors and sprocket and chain drives. All pulleys and belts and drive mechanisms should be covered or otherwise protected. Loose clothing that can get caught in machinery should never be worn at an asphalt plant.

Good housekeeping is essential for plant safety. The plant and yard should be kept free of loose wire or lines, pipes, hoses, or other obstacles. High-voltage lines, field connections, and wet ground surfaces are other hazards. Any loose connections, grayed insulation, or improperly grounded equipment should be reported immediately.

Plant workers should not work on stockpiles while the plant is in operation. Personnel should **NOT** walk or stand on the stockpiles or on the bunkers over the feeder gate openings. Many workers have been pulled down

into the material and buried alive so quickly that nothing could have been done to save them.

Burner flame and high temperatures around plant dryers are obvious hazards. Control valves that can be operated from a safe distance should be installed on all fuel lines. Flame safety devices also should be installed on all fuel lines. Smoking should not be permitted near asphalt or fuel storage tanks. Check frequently for leaks in oil heating lines and steam lines or jacketing on the asphalt distribution lines. Be sure safety valves are installed in all steam lines, and they are in working order. Make use of screens, barrier guards, and shields for protection from steam, hot asphalt, hot surfaces, and similar dangers.

When you are handling heated asphalt, use chemical goggles and a face shield. All shirt collars should be worn closed and cuffs buttoned at the wrist. Gloves with gauntlets that extend up the arm should be worn loosely so that they can be flipped off easily if they become covered with hot asphalt. Pants should remain bloused.

Exercise extreme care when climbing around the screen deck. All stairs and platforms should have secure handrails.

Hard hats should be worn by all personnel.

Truck traffic patterns should be planned with both safety and convenience in mind. Trucks entering the plant to pick up a load of hot mix should not have to cross the path of loaded trucks leaving the plant. If at all possible, trucks should not have to back up.

All operators should know the three horn signals.

- One blast on the horn, STOP,
- Two blasts, GO FORWARD,
- Three blasts, BACKUP

CHAPTER 9

WELL DRILLING SUPERVISOR

The Naval Facilities Engineering Command (NAVFAC) invests millions of dollars in water well drilling equipment and the training required to enable the Naval Construction Force (NCF) to meet water well drilling requirements at various locations and conditions throughout the world.

The COMSECOND/COMTHIRD Naval Construction Brigades require all Naval Mobile Construction Battalions to maintain an allowance of personnel qualified in water well drilling operations. The Naval Construction Training Centers (NCTC) and Regiments from both Gulfport, Mississippi, and Port Hueneme, California, provide training in water Well drilling operations. The NEC for water well driller is 5707. The means of attaining this NEC is most often through completion of the water well driller course that is offered at NCTC, Port Hueneme, California.

This chapter can only provide the basic terminology and procedures used in well drilling operations. The extensive knowledge and skills required to perform as an effective well drilling supervisor must be gained through formal training and on-job-training experience.

WELL DRILLING SUPERVISOR RESPONSIBILITIES

Successful well drilling operations are a direct result of the efficiency of the supervisor and crew. The drilling rig and its controls are not complicated and can be mastered in a short time; however, knowledge of the mechanical operations is only the start and experience is the vital element.

Drilling water wells is an art for which there are no hard-and-fast rules; it is an art that requires a good deal of common sense and improvisation. The well drilling supervisor must have a general knowledge of the physical structure of the earth's crust and the groundwater resources within. Often, problems arise in well drilling, and the well drill supervisor must be able to visualize what is occurring at the bottom of the hole. An awareness of the conditions under which groundwater occurs and of geologic conditions is a shortcut to the solution of some drilling problems that would otherwise take much time and experience to attain through the trial-and-error method.

WATER SOURCES

The source of all fresh water upon and in the land areas of the earth is the oceans. Precipitation in the form of rain, hail, sleet, or snow recharges lakes, streams, and underground water. Part of the precipitation that falls upon land areas soaks into the ground and under the influence of gravity is pulled downward until it becomes part of the *saturated zone*. Water in the *saturated zone* is referred to as *groundwater* and it is within this zone that wells are developed. Water recovered from beneath the ground accounts for a much larger percentage of our water supply than that from natural lakes or man-made reservoirs.

Above the *saturated zone* is a zone identified as the *zone of aeration*. This zone is divided into three belts: (1) the belt of soil moisture or plant root zone, (2) the intermediate belt, and (3) the capillary fringe. Neither the intermediate belt nor the capillary fringe is capable of producing water in usable quantities because the pores or open spaces between individual particles are not all filled with water. Water in the *zone of aeration* is called *subsurface water* and should not be confused with *groundwater* contained in the saturated zone where all the pores are filled with water (fig. 9-1).

The volume of water contained in the *saturated zone* is the total volume of the openings in rocks or between the individual grains of sand or gravel. These openings are referred to as the *porosity of the particular material*.

The physical characteristics of the *zone of saturation* can vary widely, depending upon the geologic formations of the earth layers; that is, sand, gravel, clay, rock, or a combination of these. This zone may also vary in depth from a few feet to many hundreds of feet.

Water may be found within the *saturation zone* in one continuous body or in alternating layers of clay and sand. This all depends on the *impermeability* or the *permeability* of the formations within the *saturation zone*; for example, while clay may hold a relatively high volume of water, the openings between the individual particles are so small that they prevent the flow of water. Clay is then said to be *impermeable*. Confined between

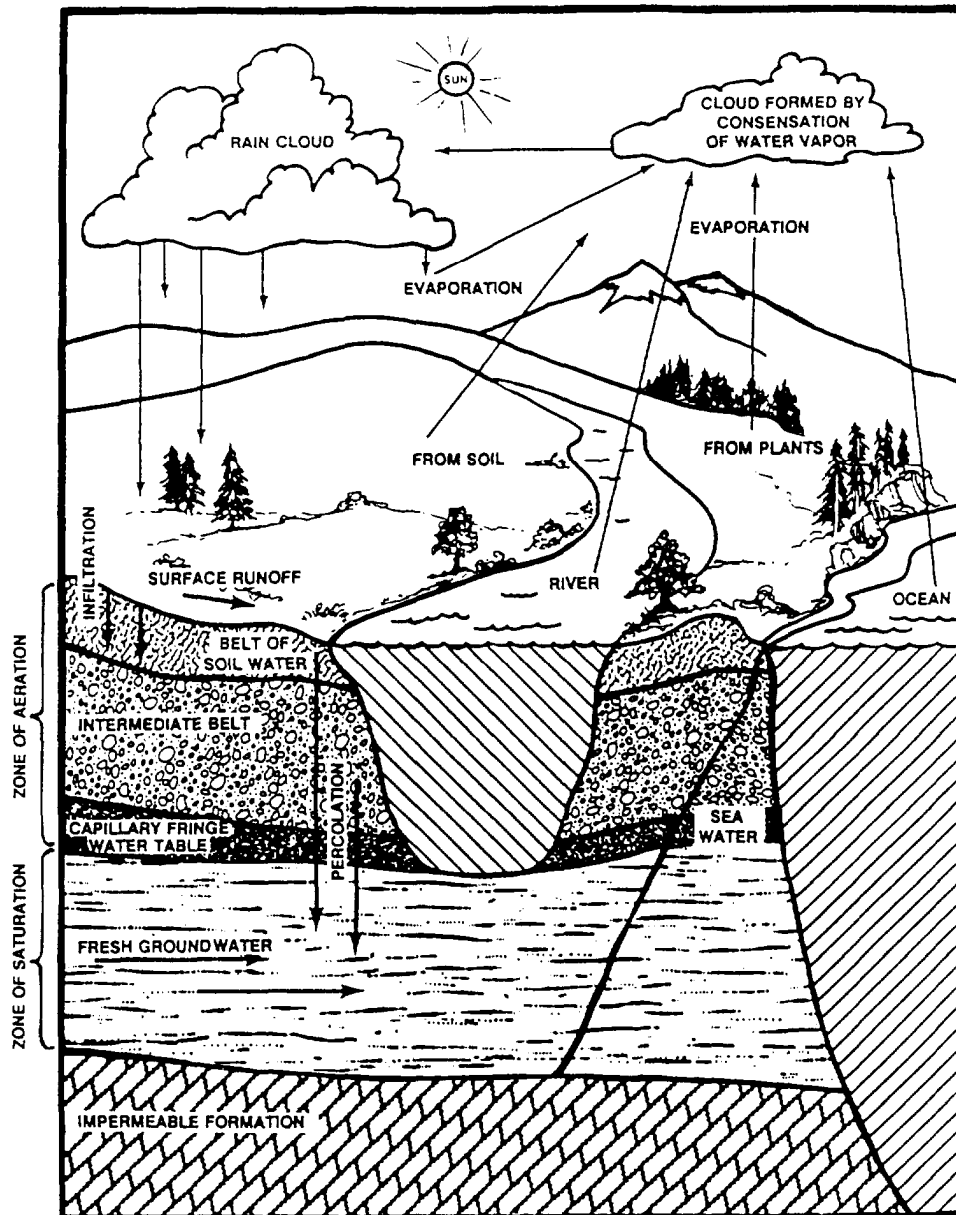

Figure 9-1.-Hydrologic cycle and zone.

two layers of clay maybe a layer of sand which is both *porous* (holds water) and is *permeable* (allows the water to flow). (See fig. 9-2).

A *porous* and *permeable* formation that can yield water in usable quantities is called an *aquifer* (fig. 9-3). If an *aquifer* is not confined by an *impermeable* layer above it, the *aquifer* is said to be under water table conditions and is subjected to atmospheric pressure. If an *aquifer* is confined both above and below and the recharge area or source of water is higher than the point where a well is to be located, the water will be under greater than atmospheric pressure and will rise to some point above the water table. When the pressure is

sufficient, the well may be free flowing. An aquifer (fig. 9-3) under this condition is called an *artesian*.

Sedimentary, igneous, and metamorphic rock formations are potential sources of water. *Sedimental rocks* are the most common *aquifers*. They are formed by the accumulation of sediments that have been deposited by water, wind, or ice. Limestone is an example of a sedimentary rock and is formed from the accumulation of chemical compounds and minerals that settle together out of water. Water percolating through cracks and joints in a dense limestone deposit results in underground streams and lakes. Throughout thick, nearly horizontal layers of limestone, as well as shale

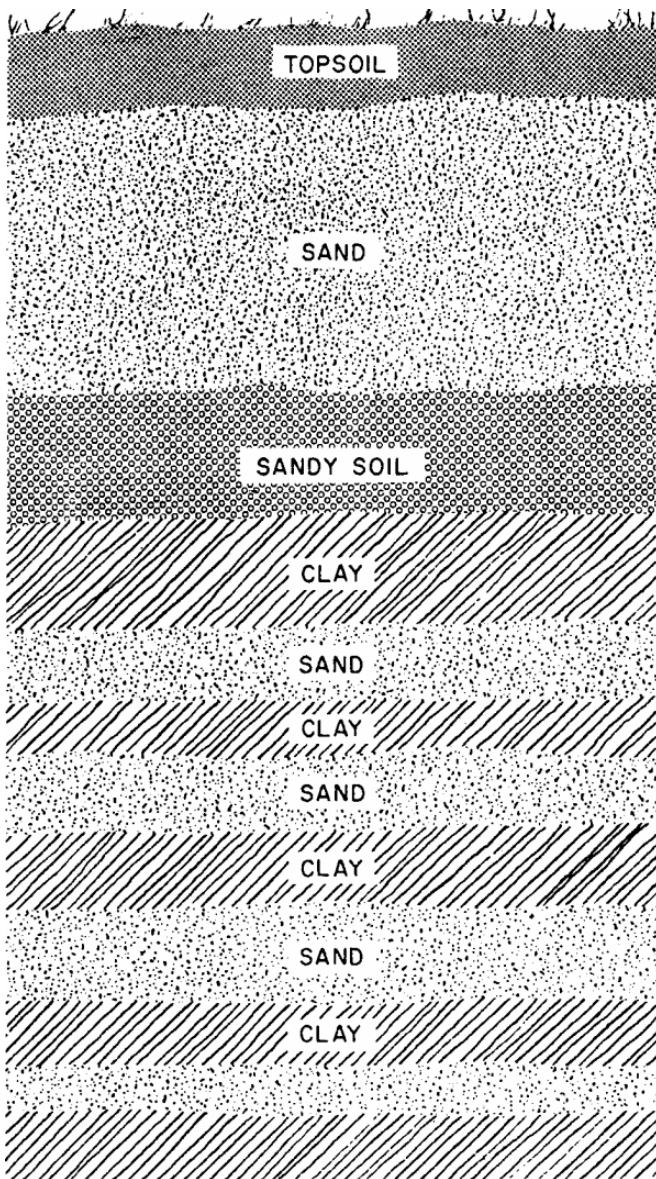

Figure 9-2.-Geologic formation of earth layers.

and sandstone, are huge reservoirs of groundwater. *Sedimentary rock* formations are among the most common and productive of all aquifers, and when found in sandy or gravel formations are easy to drill.

Igneous and *metamorphic* formations are both viewed as a group of hard, dense rocks. Unless highly fractured and occurring close to the earth's surface, they contain far less water than *sedimentary rocks*. The recovery of water from solid rock depends on the existence of many cracks, fissures, or crevices in the rock. Extremely fine deposits of sedimentary materials usually produce little water. Although *highly porous*, they are relatively *impermeable*.

Topographical features created by water action offer an excellent chance for the recovery of groundwater at relatively shallow depths. *Alluvial sedimentary* deposits are the most productive formations for groundwater. The word *alluvial* means deposited by water. Such features include the following: *alluvial valleys* that are rather extensive in area and are the sites of ancient rivers or the flood plains of active rivers; *alluvial fans* that are an accumulation of sediments at the base of mountains, deposited where drainage streams fan out; and *alluvial basins* that are essentially structural troughs created by a rim of mountains and glacial outwash.

GROUNDWATER EXPLORATION

Where extensive groundwater exploration has not occurred, maps, official documents, unofficial documents, and native experience must be used to obtain a fairly reliable indication as to a groundwater

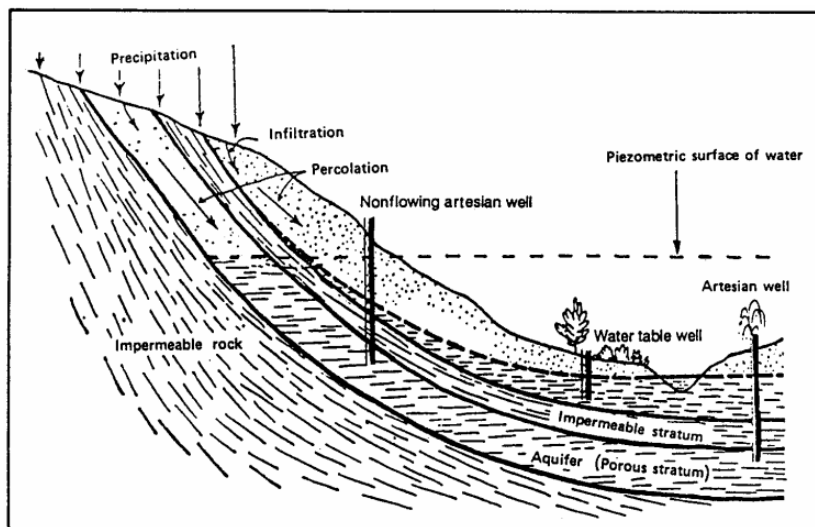

Figure 9-3.—Types of aquifers.

resource of a particular area. The information available normally will give you an idea as to the geological conditions, such as terrain and type material, approximate depth of an *aquifer* or series of *aquifers*, quantities of water that may be expected during different seasons of the year, average depth of the water table, and drilling procedures and problems that may be encountered.

Access to maps and publications is usually through hydrographic offices either on a state or national level, offices of the United States Coast and Geodetic Survey, or its equivalent in other countries, geological or university archives, battalion engineering offices, or native drillers.

When very little is known about the water resources in a particular area, the most valuable clues may come from an inspection of the outcropping of rock formations. You may need to verify your conclusions by *exploratory drilling*, which is the surest way to establish the existence of water-bearing formations.

Exploratory drilling is usually initiated as part of the groundwater study of an area before construction of water wells at a particular site.

WELLS

Wells are classified into five methods of construction. The methods are as follows: *dug, bored, jetted, driven, and drilled wells*. Each type of well has certain advantages and limitations; and the type of well to be developed depends upon the ease of construction, storage, capacity, limitations as to formations it can penetrate, and ease of safeguarding it against pollution.

A *dug well* is one in which the excavation is made by the use of picks, shovels, spades, or digging equipment, such as sand buckets or clamshell buckets.

A *bored well* is one in which the excavation is made by the use of hand or power augers.

A *jetted well* is one in which the excavation is made by the use of a high-velocity jet of water.

A *driven well* is one which is constructed by driving a pointed screen, referred to as a drive point, into the ground. Casings or lengths of pipes are attached to the drive point as it is being driven into the ground.

Dug, bored, jetted, and driven wells are relatively shallow. Generally, they are

less than 100 feet deep and may be constructed with hand tools. *Drilled wells* in the NCF are normally drilled to the depth of 1,500 feet and are constructed with portable well drilling machines.

ROTARY DRILLING

When using a hand drill to bore a hole, you press the cutting tool or bit into the material to be bored. The material is cut as you turn the bit by means of the drill handle. During the drilling process, chips of the cut material are carried to the top of the hole by the flutes of the bit. A *rotary drilling rig* operates on the same principle, except for the method of raising the cut material. This material is washed to the surface by a fluid substance instead of being carried by the bit itself. The bit of a *rotary drilling rig* is attached to the lower end of the drill pipe.

The methods of drilling for water are referred to as *rotary mud or rotary air drilling*. *Rotary mud drilling* is currently the most common method used to drill wells and is used where ground formations are loose and unconsolidated. *Mud drilling* is also used in consolidated formations but is not very efficient. The *rotary air drilling* method is preferred when ground formations are consolidated. A limitation of the *air drilling* method is the cfm output of the air compressor.

When *rotary mud or rotary air drilling* operations are being conducted and a formation that is hard to penetrate is encountered, the *down-hole-drilling hammer* attachment can be used. The *down-hole-drilling hammer* attaches to the lower end of the drill pipe and rotates as well as hammers (short rapid blows) against the hard formation (fig. 9-4). To use the

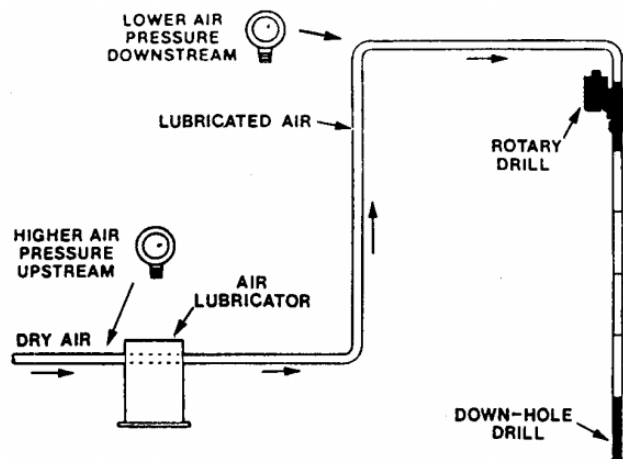

Figure 9-4.-Down-hole-drilling (DHD).

Smooth drilling, but rapid penetration, indicates fine sand. Additionally, the log includes information of the time it took to drill each foot. As drilling speed is largely determined by the composition of the formations, information from the well log may be used in graph form to reveal the top, bottom, and thickness of each formation. Clues to the composition of each formation are provided by this log and verified by the samples obtained.

Rotary Drilling Crew

The water well rig is normally operated by a *tool pusher*, a *driller*, a *derrick hand*, and a *floor hand*. For

expediency, water well drilling as performed in the NCF is a continuous operation; therefore, you are required to have more than one shift. The hours of each shift depends upon the crew size available, the experience level of the members of the crew, and the condition of the equipment; for example, two 12 hour shifts or three 8 hour shifts.

The *tool pusher* is responsible for outlining the overall drilling program and seeing that it is carried out. The *driller* carries out the drilling orders, operates the rig, and must know the depth, viscosity, density, sand content, type of cuttings, number of steel, and the psi of the mud pump. The *derrick hand* works in the mast and

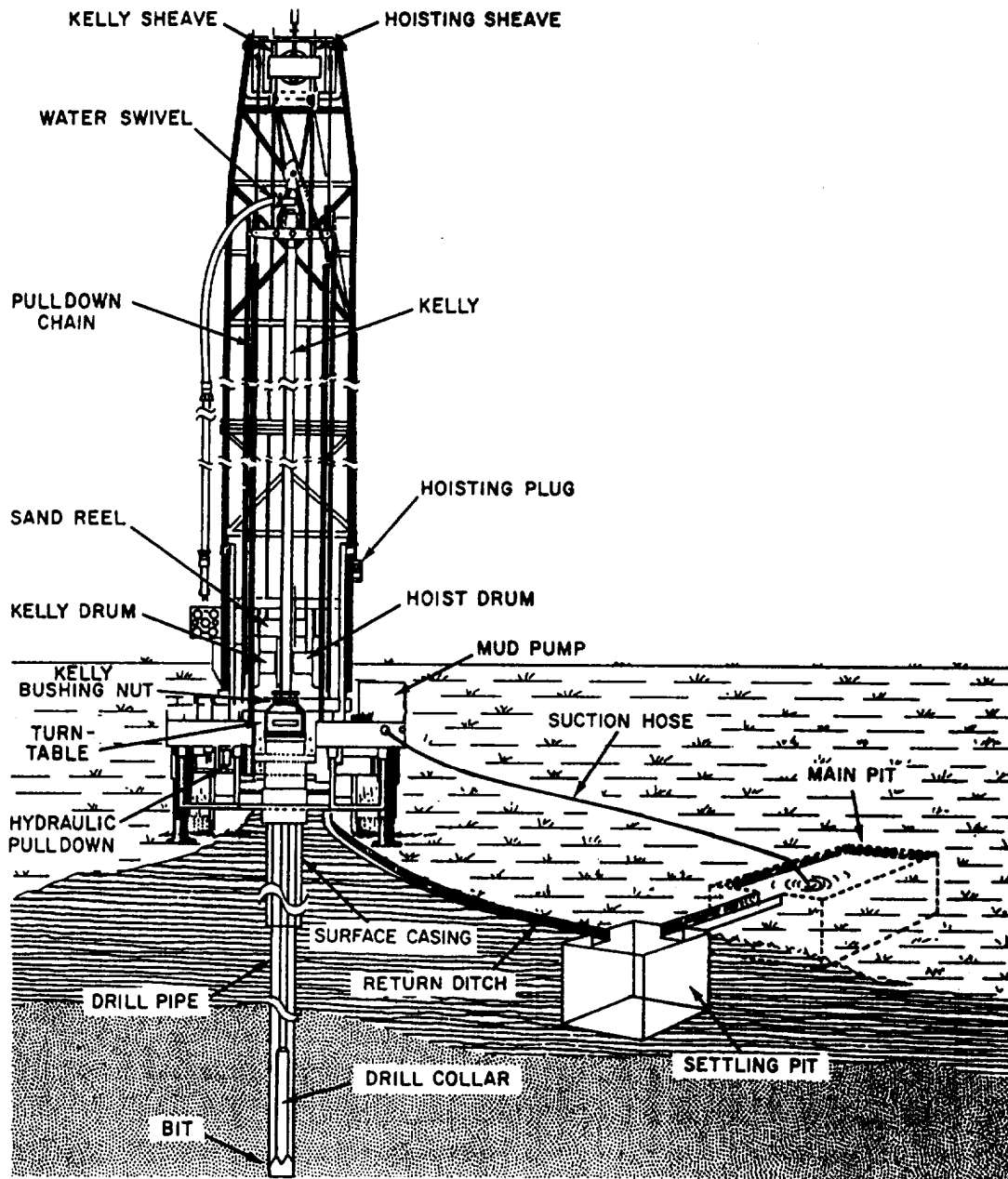

Figure 9-6.-Kelly-drive rotary method of drilling.

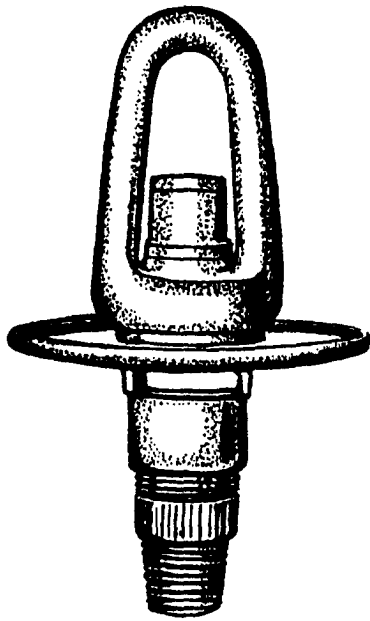

Figure 9-7.-Hoisting plug.

performs tasks, such as racking the steel pipe, screwing the hoisting plug, and handling the drill pipe or casing. The *floor hand* records the information on the drill log, records cutting samples, maintains the mud pits, and maintains all work tools and equipment on the deck of the rig.

All crew members must wear protective clothing or equipment, such as hardhats, gloves, safety shoes, and safety belts. When wearing hard hats, the *derrick hand* and any other crew member working overhead should wear chin straps to keep the hard hat from dropping on personnel below. Also, while working in the mast, crew members should attach their tools securely to the safety belt by means of line. Before ascending, they should clean their shoes of all mud and inspect footholds for grease. No crew member should wear loose or flapping clothes. Gloves should be worn for protection when

handling wire rope. Safety shoes with reinforced tops will protect toes from being crushed.

Kelly-Drive Rotary Drilling Operating Principles

The basic components of a *kelly-drive rotary drilling rig* are the derrick and hoist, kelly, turntable, drill pipe, bit, and pump (fig. 9-6).

The drill pipe comes in lengths that are joined together, as the depth of the well increases. The top joint of the drill pipe is connected to the kelly, which is a splined hollow shaft, that passes up through the turntable and kelly bushing. This bushing is grooved to fit the splines on the kelly. When rotated by the turntable, the kelly is free to move up and down. The pump forces a mixture of clay and water through the kelly and drill pipe.

A water swivel, suspended from above, is attached to the top of the kelly. It allows the kelly, drill pipe, and bit to rotate with the driving mechanism. The water swivel and kelly are raised and lowered by a cable that runs from the swivel over the sheave at the top of the derrick down the kelly drum. The kelly drum brakes and wire rope control the pressure and rate of feed to the bit by holding off or applying the weight of the drill pipe.

The accessories of a *kelly-driven rotary drilling rig* include the hoisting plug, slips, drill collar, kelly sub, and casing. The *hoisting plug* (fig. 9-7) is the connecting link between the hoisting line and the drill pipe. It swivels so that the drill pipe is free to turn while being hoisted. The *slips* (fig. 9-8) are used to hold the drill pipe when it is being moved in or out of the hole while a joint is removed or added. The slips are circular wedges made in two or four pieces and fastened together in sets or pairs. Teeth on the inside of each slip grip the outside of the drill pipe. The slips are tapered in such a manner that when set around the drill pipe and pulled into the turntable, they grip the drill pipe securely. The *drill*

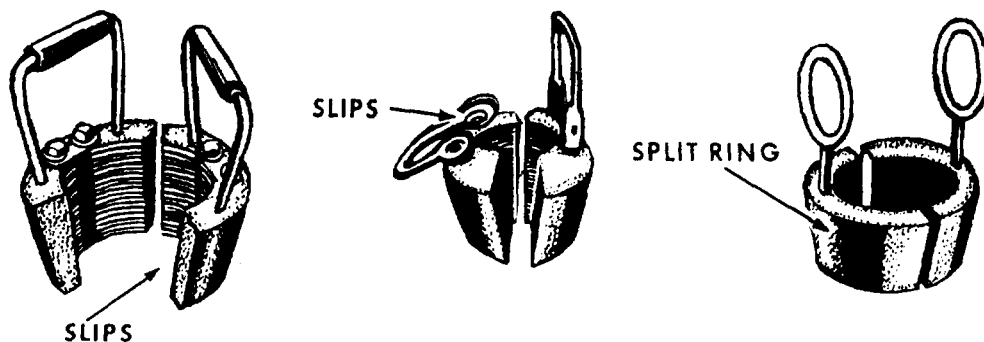

Figure 9-8.—Slips.

collar (fig. 9-9) joins the bits and drill pipe and helps stabilize the bit and keeps the hole uniform and straight. This collar is 10 feet long and has a diameter larger than that of the drill pipe, yet small enough to clear the wall of the hole. The *kelly sub*, or *wear sub*, connects the kelly to the drill pipe. When it becomes worn, it can be changed instead of the entire kelly.

In areas where surface formations are soft or sandy, it is necessary to set the casing to keep the walls of the hole from caving and to prevent the hole from being enlarged by the washing action of the circulating fluid. Sometimes, the hole is reamed or enlarged to set the casing on a firm foundation. To run the casing, you should attach a sub to the hoisting plug and threaded into a length of the casing. Some casings are not threaded and must be welded together. The welded casing can be washed and cooled down by the mixing hose from the mud pump and then run into the hole in the same manner as the drill pipe. If the hole has caved so the casing will not go down, attach the swivel to the casing with a sub

and circulate fluid through the casing. This is called washing down and is sometimes used to wash the casing to the bottom of a caving hole.

The kelly and drill pipe are hollow to allow fluid mixtures of clay and water, air, foam, and so forth, to be pumped through them to the bit. The fluid circulates through the drill pipe and out through the bit, where it sweeps under the bit and picks up the material loosened by it. It then carries the material to the surface through the space between the drill pipe and walls of the well. Fluid from the well overflows into a ditch and passes into a settling pit, where the cuttings settle. The fluid free from coarse material and containing only fine-grained clay in suspension, flows into another pit and is picked up by the pump for recirculation in the well.

Enough mud-laden fluid (drilling mud) must be circulated to cool and clean the cutting tool properly and to rise in the hole fast enough to carry the cuttings with it. The weight and viscosity of the fluid, aided by the

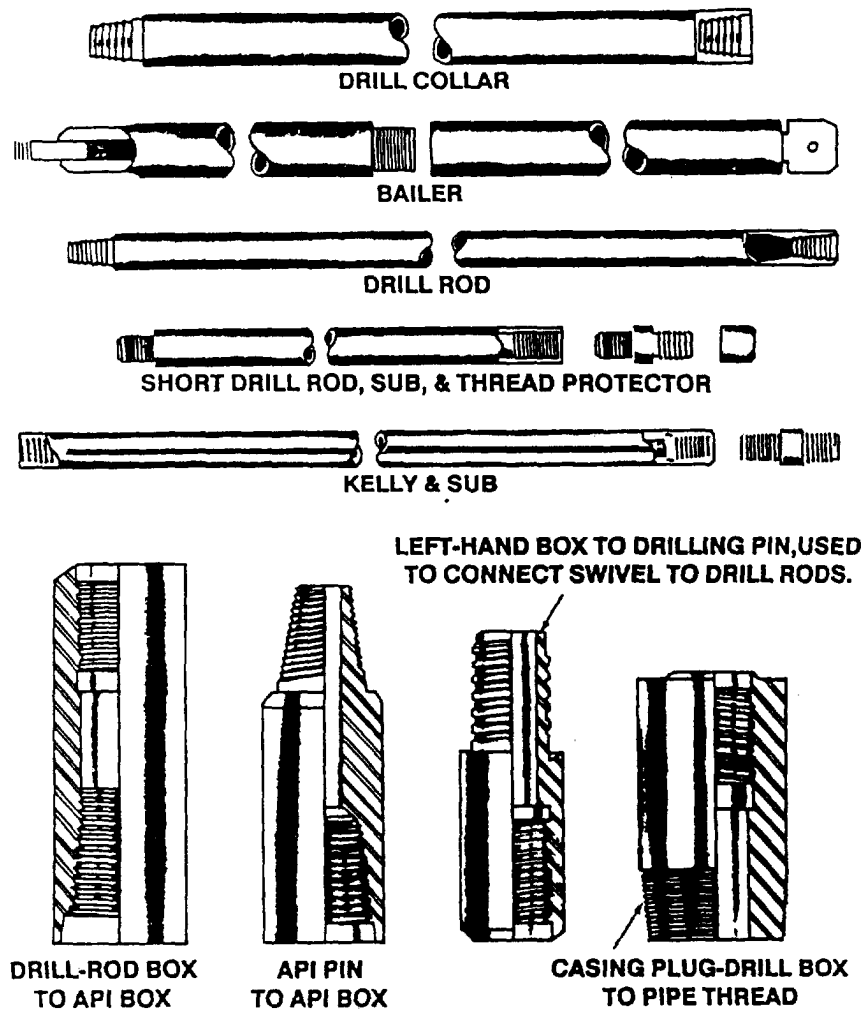

Figure 9-9.-Drill steel, collars, and subs.

plastering action of the fluid spiraling against the wall of the well, prevent the wall from caving-in. The consistency of the mud must permit the cuttings to be held in suspension in the hole, yet permit them to settle out in the surface pits. Although some local clays will mix to an acceptable consistency, many do not. A commercially prepared clay, such as Bentonite, must be added to improve the density of the mud.

Kelly-Drive Rotary Drilling Operations

In well drilling, details of setting up the rig will vary, depending on the rig used. Well drilling rigs can be skid-mounted, trailer-mounted, truck-mounted, or even self-propelled. In any case, it is necessary that the rig is level and cribbed with dunnage before operations begin. Keeping your rig level helps to keep the hole straight during the drilling operation.

While the rig is being leveled, part of the crew can excavate the mud pits (fig. 9-10). The size of the pit depends on the water supply, depth of drilling, and the type of material drilled. A fluid return ditch should be dug from the drilled hole to the settling pit and from the settling pit to the main pit. The ditches enter and leave the settling pit in such a reamer that the flow of fluid is reversed and causes the cuttings to settle, thus keeping them from flowing into the main pit. The pits are lined and sealed with drilling mud and then water is added. Once the mud pits are full of water, the drilling mud can be added and mixed to the right viscosity with the mixing hose. The suction-hose screen is then placed in the main pit at the opposite end of the return ditch. The suction hose is submerged at all times but does not lie on the bottom.

Keep the circulating fluid as clean and free from abrasives as possible to protect the pump parts. The settling pit should be cleaned when 75% full of cuttings so that cuttings will not be placed in circulation. The pit is cleaned when the rig is stopped for a drill pipe change, or drill bit cleaning.

A water supply is essential when drilling wells by the rotary method. There is no set rule as to the amount of water required to drill any one hole. In some cases, where the formations are compact, 3 to 4 gallons of water per foot of hole drilled is sufficient. In other cases where formations are loose and extremely porous, a large supply of water is required. For ordinary purposes, 750 to 1,000 gallons of water per 8-hour shift is needed. Skid-mounted and canvas tanks are usually apart of the drilling outfit.

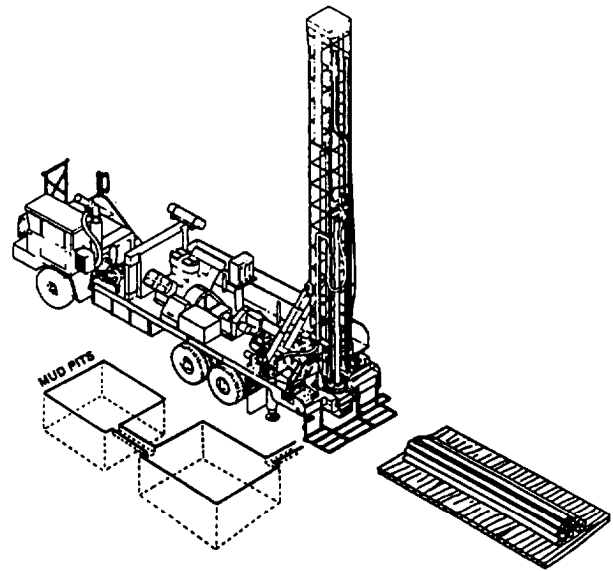

Figure 9-10.-Mud pits.

Even holes spaced only a short distance apart and in the same soil formation may require different drilling techniques. The drill supervisor must be capable of selecting the best bit for penetrating a particular formation. Some examples of rotary drilling bits are shown in figure 9-11. Either the roller or the cone type of rock bit can be used to penetrate moderately hard to hard formations; a fishtail, three way, or pilot bit can be used to penetrate soft formations and overburden material.

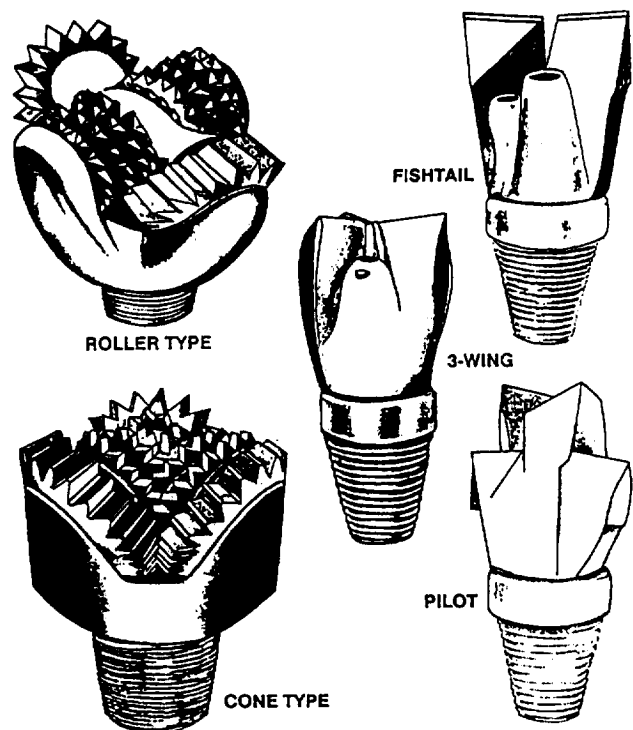

Figure 9-11.-Drill bits.

Before starting to drill with any particular rig, thoroughly read and understand the manufacturer's manual for the machine. Make sure the drilling table, or platform, is clean, dry as possible, and free of loose objects. Doing so will help prevent personal injury and loss of tools down the drill hole. For safety, ensure that the sheave guards remain in place over moving gears and chain drives while the rig is operating. Drillers learn from experience why a well is dug in a certain way and can visualize conditions at the bottom of the hole. No set rules have been established to follow for adjusting speeds of rotation and bit pressures.

In general, you proceed to set up the rig as follows: Move the rig into position on the selected site. Use the hydraulic outriggers to level the rig and take the weight of the rig off the axles. Next, raise the mast and lock it in place. Now check to see that the rig is slightly higher in the rear to allow for settling during the drilling operation.

For *kelly-drive rotary drilling* you continue by doing the following:

1. Run the kelly through the turntable and thread the pilot bit to the kelly.
2. Place the turntable transmission in the proper gear for the soil formation being drilled.
3. Engage the turntable clutch and release the kelly brake slowly to lower the bit into the ground.
4. Engage the mud pump and lower the kelly after the bit has spudded into a depth of 6 to 12 inches.
5. Proceed to drill to the depth of the kelly. Raise the drill bit 6 to 10 inches, circulate to bring all cuttings to the surface, then shut off the mud pump and stop the turntable.
6. Next, raise the kelly until the pilot bit reaches the surface. Remove the pilot bit and lift the kelly clear of the turntable.
7. Move the turntable from its position over the hole. Raise, then lower, a surface casing into the hole, using the hoisting drum. The surfacing casing keeps the well from caving-in from the surface.
8. Once again, position the turntable over the hole.
9. Next raise, then lower, a length of drill pipe into the hole through the turntable, using the hoisting line. The slips will hold the drill pipe in place in the turntable.
10. Follow up by lowering the kelly and attaching it to the drill pipe. To keep these parts from seizing, apply dope on the kelly coupling.

11. Using the kelly drum, raise the kelly and attached drill pipe just enough to enable the slips to be removed.

12. Lower the kelly and drill pipe so the kelly bushing nut slips into the turntable.

13. Engage the turntable and start the mud pump. In doing so, you lower the kelly to drill again.

14. The slips hold the drill pipe in place until the breakout thongs are attached to the kelly. Rotate the turntable slowly until the kelly is unscrewed from the drill pipe.

15. Raise the kelly far enough so another length of drill pipe can be added to the pipe remaining in the hole. Reconnect the kelly and lower into the turntable.

16. Start drilling again until you reach the end of the kelly.

Keep repeating this procedure until you have drilled to the desired depth. You are now ready to complete the drilling operation. Proceed to remove the drill pipe by pulling it out with the hoisting line. Finally, lower the casing with the screen to the desired depth.

If you must change bits before the desired depth is reached, disconnect the kelly and attach the hoisting line to the drill pipe. Pull the drill pipe a length at a time, placing the bottom ends on a board to help keep them clean.

Top-Head Drive Rotary Well Drilling Rig

The *top-head drive rotary well drilling rig* is a special top-head drive ISO/airtransportable water well-drilling rig (ITWD) (fig. 9-12) that the development and production effort was conducted or controlled by NAVFAC towards providing the NCF with the capability for rapid water well drilling in a variety of environments.

The self-propelled ITWD design has a lightweight derrick a telescoping mast, and a top-head rotary drive actuated by hydraulic cylinders able to accommodate 20-foot-long sections of drill pipe and well casings. When the derrick is lowered for transport, the entire rig weighs 23,000 pounds and is capable of fitting inside a standard cargo container without disassembly and is air transportable on board a C-130 aircraft. The ITWD is capable of *rotary drilling* 12 1/4-inch holes to 1,250-foot depths and *down-hole-drilling (DHD) hammer (percussion) drilling*, 6-inch holes to 1,500-foot depths. The ITWD will travel at a top speed

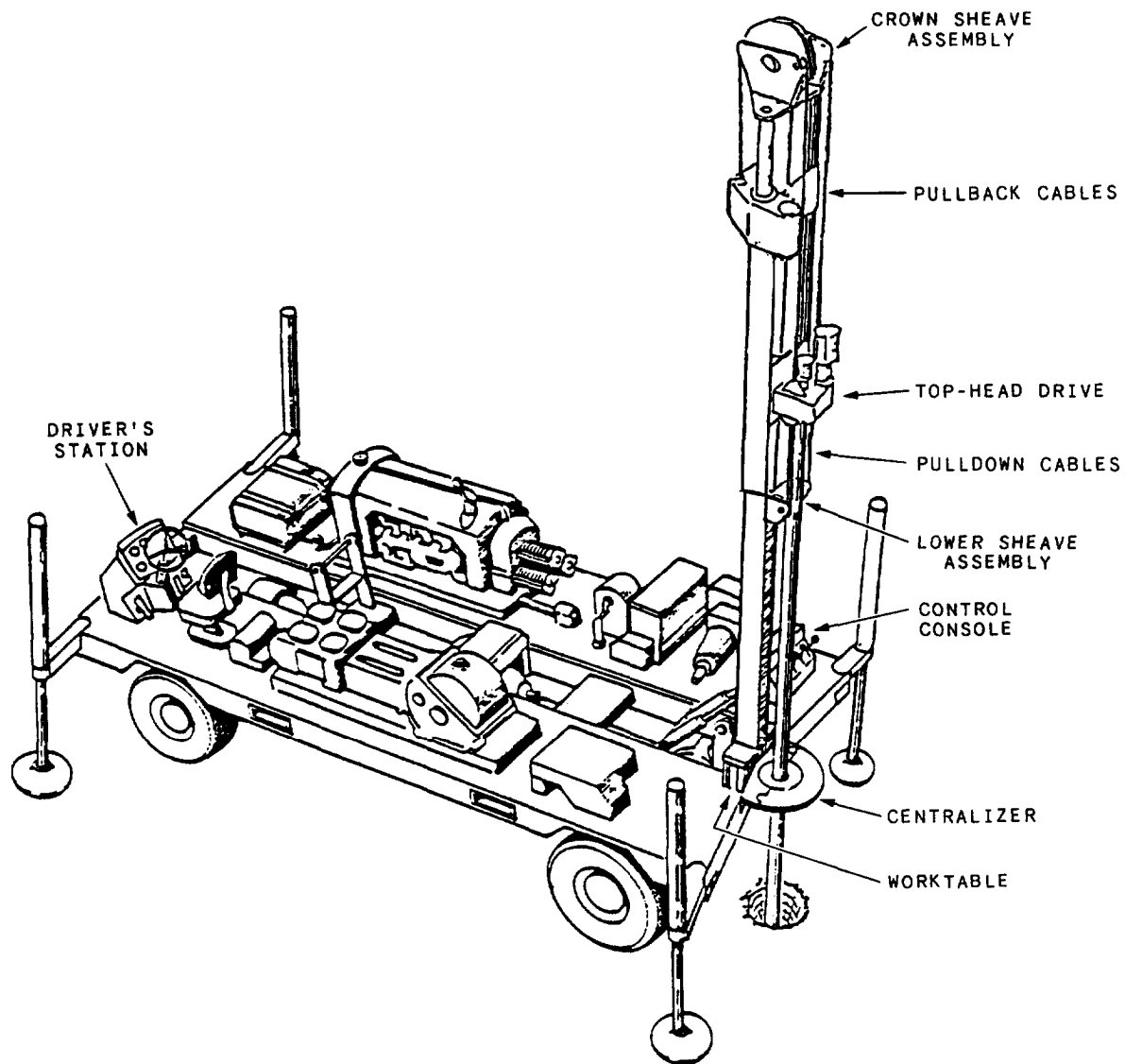

Figure 9-12.-Top-head drive ISO/air-transportable water well drilling rig.

of 10 mph over unpaved roads and has a cross-country rough terrain capability.

ITWD Components

The ITWD derrick consist of the telescoping mast structure, the pulldown/pullback mechanism, the top-head assembly, and the hoist assembly. Other components are a stabilization system, main frame, handling equipment, hydraulics, control console, and so forth.

The drill derrick system is capable of generating 15,000 pounds pulldown and 30,000 pounds pullback force through the top-head during the drilling operation. The top-head drive is a variable speed drive that imparts rotation and torque to the drill pipe for drilling and has

an rpm range from 0 to 200 rpm. The tophead drive is mounted to a carriage that is free to move up and down over the length of the moving mast section. The tophead drive also has a hollow spindle for injection of air or mud, giving the ITWD capabilities for *rotary air* or *rotary mud drilling*.

The hoist system is attached to the side of the derrick and operates independently of the derrick operation and is rated for a 3,000-pound hook loading. This capacity is sufficient to add and remove 18.5-foot drill pipes and to set typical 20-foot casing and surface pipe. The hoist is capable of lifting up to 180 feet of 4 1/2-inch drill pipe when "tripping out" the drill hole. When increased hoisting is required for lifting longer drill strings, the top-head drive that has a capacity equivalent to its

30,000 pullback rating can be used as an additional hoist.

A split centralizer and pipe-handling system located on the ITWD worktable is used to break and make drill pipe connections, to support the drill string during pipe handling, to provide a centralizer bushing for the drill string, and to aid in setting casing and making casing joint. The centralizer is a split design consisting of a rear section welded to the main frame and a removable forward section. The forward section is held in place by two pins and can be manually swung out or detached to facilitate setting large diameter casing or surface pipe. The forward section is removed during transport and stored on top of the worktable. The centralizer accommodates various sizes of split bushings to adapt to a number of drill pipe, casing, and down-hole-drilling hammer diameters.

A hydraulically powered breakout wrench is also mounted on the worktable. This wrench is used with a manual holding wrench (used to support the drill string and stop rotation) to make and break pipe and casing joints.

Top-Head Drilling Operations

All personnel assigned to drill with the ITWD should thoroughly read and understand the operator's manual before proceeding with any drilling operations. Additionally, **SAFETY IS PARAMOUNT** over all actions performed during drilling operations.

In general, you proceed to set up the rig as follows: Move the rig into position on the selected site. Use the hydraulic outriggers to level the rig and take the weight of the rig off the axles. Ensure adequate overhead clearance; then raise and lock the derrick.

For the *top-head drilling rig* proceed with the following:

1. Attach the centralizer half to the worktable.
2. Install the centralizer bushings.
3. Place the bottom holding wrench in position.
4. Dope (lubricant for threads) the top-head spindle sub threads.
5. Lower the hoist and attach the hoist plug.
6. Raise the top-head.
7. Dope the tri-cone bit threads (down-hole-drilling hammer treads if hammer drilling).
8. Manually thread the bit into the bit sub.

9. Wrap the mud flinger around the bit sub.

10. Dope the hoist plug threads and thread into the bit sub.

11. Raise the bit sub with the hoist and insert into the centralizer bushing.

12. Insert the holding wrench to the support bit sub; close the forward half of the centralizer and pin it shut.

13. Remove the hoist plug from the bit sub.

Installation of the Drill Pipe:

1. Slide the drill pipe sling over the drill pipe.
2. Attach the hoist cable to the drill pipe sling and hoist the drill pipe into position over the bit sub.
3. Lower the top-head into position with the rotation on slow.
4. Tighten all connections and raise the drill slightly off the holding wrench and remove the holding wrench.

Rotary Mud Drilling:

1. The mud pits for top-head drilling are dug and designed, as shown in figure 9-10.
2. Connect the suction hose to the mud standpipe.
3. Place the suction hose into the mud pit and connect the hose to the mud pump inlet.
4. Set the engine speed to the manufacturer's recommendations and open the mud pump valve.
5. Control the mud flow by adjusting the mud pump speed.
6. While drilling, adjust the top-head drive spindle rotation and pulldown speed and monitor the mud pump stand pressure to avoid a plugged drill bit or loss of pump prime.
7. Upon completion of the hole, place the suction hose in a source of clean water and flush the drill pipes and bit.

Rotary Air Drilling:

1. Lower the bit to within 4 inches of the ground, and connect the flushing line to the air compressor.
2. Turn on the compressor, open the air valve, and set the engine speed at the speed recommended by the manufacturer.
3. Set the pulldown regulator to a minimum and start the top-head drive spindle rotation, and set the pulldown speed to LOW.

4. Monitor the pull-down and top-head drive spindle rotation pressure gauges to avoid overthrust and monitor the air line pressure to avoid a plugged bit.

5. When the drill hole is complete, shut down the air and repressurize before “tripping out” the hole.

Down-Hole-Drilling (DHD) (fig. 9-4):

1. Use the percussion button bit.

2. Use the holdback regulator to control feed forces.

3. Switch on the DHD line oiler before operating the DHD. (A air line lubrication system injects a determined rate of oil into the flushing hose to lubricate the DHD hammer when air hammer drilling.)

4. Use the DHD line oiler regulator to adjust the oil flow and check the oil flow by placing a piece of cardboard under the spindle sub and inspect the pattern.

5. Monitor the DHD frequency and cuttings to determine proper feed force.

Setting Casing:

1. Retract the top-head drive and unpin and swing out the forward centralizer.

2. Replace the centralizer bushing with casing clamps.

3. Install the choker sling on the first casing, and hoist the casing above the drilled hole.

4. Lower the casing into the hole until the top is about 1 foot above the worktable.

5. Close the centralizer and pin it shut.

6. Remove the choker sling and attach it to the next casing. Hoist the second casing above the first.

7. If the casing is plastic, install the collar and cement joint. If weld type, join shoulders and weld. And if thread type, clean threads and dope and tighten with a chain wrench or breakout wrench.

8. Set the screen and rest of casing.

9. Unpin and swing out centralizer.

10. Gravel pack and grout as to the construction specifications.

DRILLING DIFFICULTIES

Lost circulation is one difficulty you may encounter when drilling. Sometimes it occurs in zones of *high porosity* that usually contain large supplies of water. A

test of the well should be made whenever circulation is lost. Formations that draw off or absorb all or part of the circulating fluid offer problems, ranging from minor inconveniences and loss of time to extreme conditions that render rotary drilling impossible.

Formations that contain joints and fissures, such as quartzite, sandstone, limestone, and dolomite, present problems arising from caving, abrasion, and complete loss of circulation.

Shale that is jointed and fissured seldom draws off an excessive amount of circulating mud; however, drilling fluid that is absorbed causes the shale to swell and heave, filling up the drill hole. This has been overcome by the use of special drilling fluids. This condition is rare, and satisfactory drilling progress can usually be made by using a drilling fluid of high viscosity and weight.

Sands and gravel often absorb enough drilling fluid to hinder drilling progress. Fluid loss, which, in most cases, will be continuous, should be replaced with mud, not water. Water, when used to maintain sufficient volume for circulation, soon lowers the viscosity and weight of the mud-water mixture, and caving results.

Two methods are used to regain lost circulation. The preferred method is to drill through the zone of lost circulation and to set a string of *conductor casings* below the *porous zone*. The chief requirement for this procedure is a plentiful supply of water to circulate the cuttings away from the bit and into the formation. Mud is desirable but the quantity needed usually precludes its use. When using water to carry off the drill cuttings, always remember to continue to operate the pump for a few minutes after drilling has stopped. This flushes the cuttings out of the hole and prevents the drill pipe from sticking when it is stopped to make a connection. In extreme cases where it is necessary to drill as much as 100 feet or more through a formation in which circulation is lost, a small quantity of mud is spotted around and above the bit while an additional joint of pipe is installed in the drilling string. This prevents excessive settling of the drill cuttings and consequent sticking while the drill pipe is standing. When the bottom of the zone has been reached, drilling is continued into the underlying formation for about 50 feet to give room for cementing the casing. When the casing has been run and cemented, the ordinary rotary drilling procedure is resumed.

In the second method, circulation can usually be regained by mixing a clay-type material with the drilling fluid that can be bought commercially. The water well

drilling school located at NCTC, Port Hueneme, uses the second method when circulation is lost during drilling operations; however, to regain circulation the school recommends dropping into the hole approximately a yard of 3/4-inch to 1-inch clean aggregate to regain circulation. The amount of clean aggregate used depends on the size of the area in which circulation is lost. If circulation is lost in cavernous limestone, the fluid level in the hole is checked and tested for fresh water.

A cheap, abundant supply of water is often the determining factor between a straight well hole and a loss of time, labor, and equipment.

Much depends on the experience and ability of the driller when drilling through difficult formations. The driller will have to use the capabilities of the machine and experience to keep the hole straight. The harder formations, especially those which are dipped and those that are broken and crevice, present many difficulties. Use only a roller and *three- or four-wing drag bits* for this type of drilling. *Fishtail* and some of the *single-cone roller bits* are not suitable for any except the softest formations.

Crooked Holes

One way to detect crooked holes during drilling is to watch for wear on the drill pipe. If wear occurs at a set distance from the top of the ground, it indicates the hole was deflected at this point. When drilling, detection of deflections of the bit and drill pipe is not easy because the hole can be quite crooked without noticeably affecting the operation of the rig. The driller must be alert to any indication that the hole is going crooked.

To avoid crooked holes, make sure that the bits are of a form and size that prevent undue eccentricity during rotation. They must be sharp and dressed to proper gauge. The drill collar that holds the bit to the lower end of the drill pipe must be large enough in diameter to hold the pipe centrally in the hole and to prevent the bit from working off to one side. Avoid excessive bit pressures.

Another difficulty sometimes encountered is the sticking or freezing of the drill pipe. An inexperienced drill operator can cause the drill pipe to stick by not circulating mud in the hole. The drill pipe is kept free in the hole by simultaneously rotating the pipe and circulating a mud-laden fluid. If either operation stops, only a short time should elapse, depending upon the formation being penetrated before pulling the bit into the casing (or out of the hole altogether, if no casing has been installed). Failure to do this often causes the drill

pipe to become stuck due to sand and cuttings settling around it.

The drill pipe may also stick in some formations if lost mud is replaced with water and not mud. Formations are often encountered that drain off or absorb a certain amount of the drilling mud. If this mud is replaced with clear water to keep up the fluid level in the hole, the water thins the mud to a point where the mud exerts a cutting action on the walls of the hole and causes extensive caving around the drill pipe, fastening it securely in the hole.

Inadequate equipment may cause the drill pipe to stick; for example, a mud pump with insufficient capacity would not keep circulation moving fast enough to prevent drill cuttings from settling out and jamming the drill pipe.

Balling up may also cause the drill pipe to stick. *Balling up* is the accumulation of soft, sticky shale or clay around the drill collar and bit. Occasionally, mud collars are formed that are forced up the hole by the pump action. This balling, if allowed to continue, forms a coating around the drill collar that sticks to the drill pipe securely when it is raised off the bottom. The usual cause of balling up is a high rate of penetration, combined with a speed of rotation insufficient to mix the drill cuttings thoroughly. To overcome these conditions, the drill operator should raise the pipe frequently by raising it off the bottom 4 or 5 feet and then drop the pipe while it is rotating rapidly. If this is done and if the rate of penetration is held to a speed that gives the circulating fluid time to mix the drill cuttings thoroughly, this source of trouble can be held to a minimum.

As mentioned before, loss of circulation may result in a stuck drill pipe. Loss of circulation is especially troublesome in *porous limestone* that contains much water. When one of these *porous zones* is penetrated by the drill, the pressure of the drilling mud causes it to drain off rapidly into the formation. The sudden reversal of circulation in the hole deposits the suspended drill cuttings around the drill pipe. This often happens so suddenly that there is no time to remove the drill pipe.

Recovery of Stuck Drill Pipe

Every precaution should be observed to prevent the drill pipe from sticking as only extreme scarcity of drill pipe justifies extensive recovery operations in drilling shallow wells; however, there are a few things that can be done successfully with the equipment at hand,

depending upon how tightly and in what manner the drill pipe is stuck.

When the drill pipe becomes stuck by *balling up* while drilling in soft shale or clay, it can often be loosened by circulating clear water. An upward strain should be kept on the pipe while circulating the water.

When the pipe is stuck by sand or drill cuttings that have accumulated in the hole, circulation should be maintained with the heaviest mud obtainable. When possible, the pipe should be worked. Any movement transmitted through the pipe, however slight, helps dislodge the sand particles into the mud stream that carries them to the surface.

When a drill pipe is stuck through lack of circulation, there is not much that can be done to recover the entire string of pipe; however, an attempt should be made to pull the pipe with jacks. Sometimes the pipe can be recovered by mixing the proper circulating fluid and circulating it while working the pipe with both the rotating and hoisting mechanisms. In some instances, the pipe can also be recovered by cutting it with a blasting charge in the bottom of the hole or about where the pipe is stuck.

Fishing

One of the major problems encountered when well drilling is the recovery of tools lost in the well. Lost tools are recovered by fishing. The most frequent cause of tool loss in rotary drilling results from the drill pipe twisting off. Such "twist offs" usually occur near the lower end of the pipe. They may consist of a simple shearing off from the pipe or of a fracture at a coupling. The accidental dropping of a drill pipe into a hole also calls for fishing. Among less common accidents requiring fishing is the dropping of tools, such as slips or wrenches, into the hole. When a break occurs, remember the exact depth of the break. This helps in locating the tops of the tools and coupling to them with a fishing tool. Recovery of lost drill pipes depends upon whether the driller can set the tool down on top of the pipes and connect to them.

Some of the more common fishing tools are the *circulating-slip overshot*, the *die overshot*, and the *tapered fishing tap* (fig. 9-13).

The *circulating-slip overshot*, as implied by its name, provides circulation through the lost pipe to assist removal when fishing. This tool is similar to the die overshot in its action but provides a watertight coupling between the drill pipes.

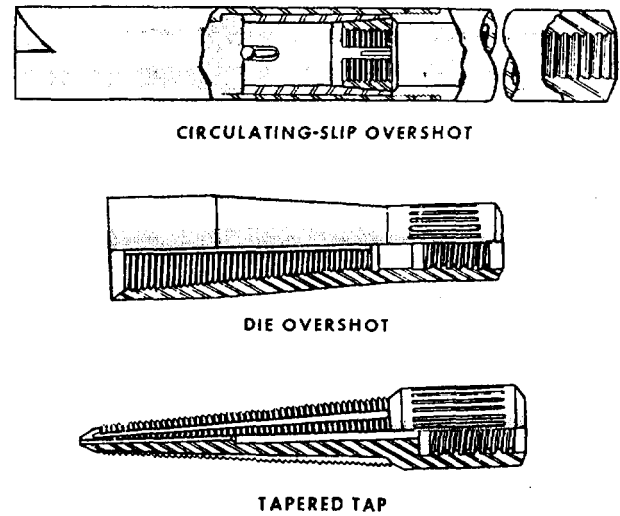

Figure 9-13.-Tap and overshot fishing tools.

The *die overshot* is a long-tapered die of heat-treated steel. When fitted over the lost drill pipe and rotated, the die overshot, like the fishing tap, also cuts its own threads. The tapered thread is fluted to permit the escape of metal cut by the threads. The upper end of the die has a thread to fit the drill pipe. The die is hollow but, as is also true of the tap die, circulation cannot be completed to the bottom of the hole through the lost pipes because the flutes allow the fluid to escape.

The *tapered fishing tap*, as its name implies, is a fluted tapered tap made of a heat-treated steel. Its action is similar to that of a machine tap, as it cuts its own threads when rotated, and thus grips the lost drill pipe.

REMEMBER: In many shallow wells, it is more economical to abandon the hole than it is to fish for the lost tools.

WELL DEVELOPMENT AND COMPLETION

Once an aquifer has been tapped by the drilled hole, the important and essential phase of completion and development must be accomplished in order to assure maximum yield under sanitary conditions. Development and completion of a well includes

1. setting the casing and screens,
2. removal of the drilling fluid, and
3. stabilization of the aquifer by removal of a predetermined percentage of the fines, grouting, and sterilization of the well.

The first operation after drilling the hole (fig. 9-14) is to set the screens and casing (fig. 9-15). The casing prevents collapse of the drilled hole walls in unconsolidated formations. The screens prevent collapse of the drilled hole wall in the aquifer while allowing water to enter the casing freely. After the casing is set, the well is gravel-packed (fig. 9-16). Gravel packing is placing graded aggregate on the outside of the casing to allow for more production and prevent "fines" from entering the well pump, tanks, and systems.

When the screens, casing, and gravel pack have been completed, the well is ready for development. Development is accomplished by removing the drilling fluid from the aquifer and the employment of any means that induces an alternating flow of water in and out through the screens. This action stirs up the unconsolidated material in the aquifer and allows removal of the finer particles. Gradually, the coarsest particles become stabilized around the screens, and the last vestiges of drilling fluid are removed, permitting the well to yield its maximum capacity.

A variety of methods are used for setting screens, removing drilling fluid, and developing aquifers. The method used for either of these operations is often determined by the tools and equipment available.

When development of a well is complete, it is required to grout as a sanitary protective measure to prevent seepage of surface water or contaminated water from water-bearing formations above into the aquifer. Grouting is accomplished by cementing from the top of the gravel pack to the annular space between the well wall and casing (fig. 9-17).

WELL DRILLING SAFETY

Safety is paramount in all construction operations. You must always be safety conscious and on the alert for potential dangers to personnel and equipment. Safety considerations cannot be overemphasized.

1. Hard hats area must and should always be worn.
2. Gloves should be worn to protect hands when handling wire rope.

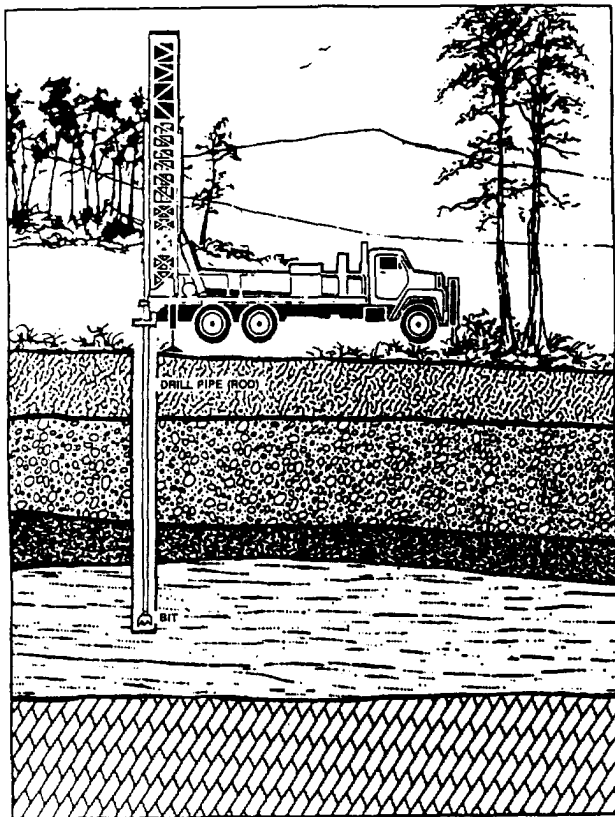

Figure 9-14.-Drilling the hole.

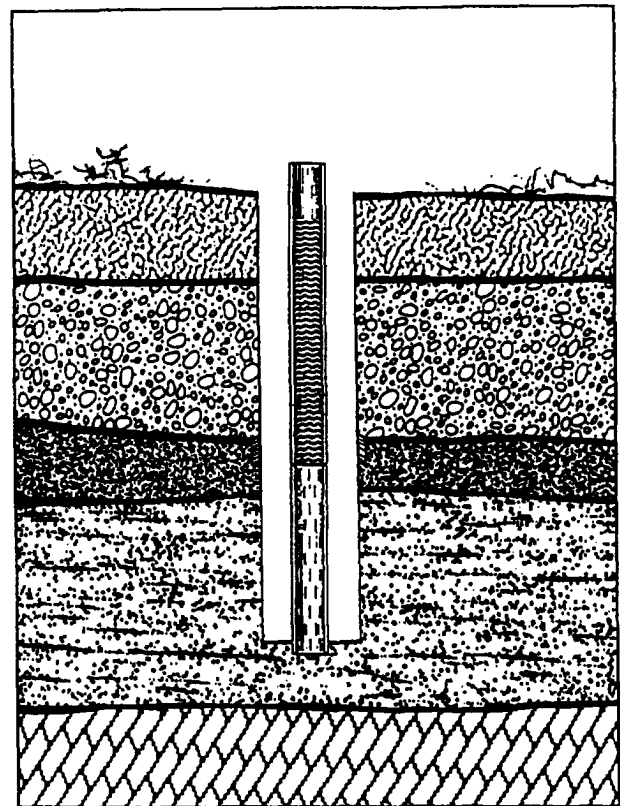

Figure 9-15.-Casing the hole.

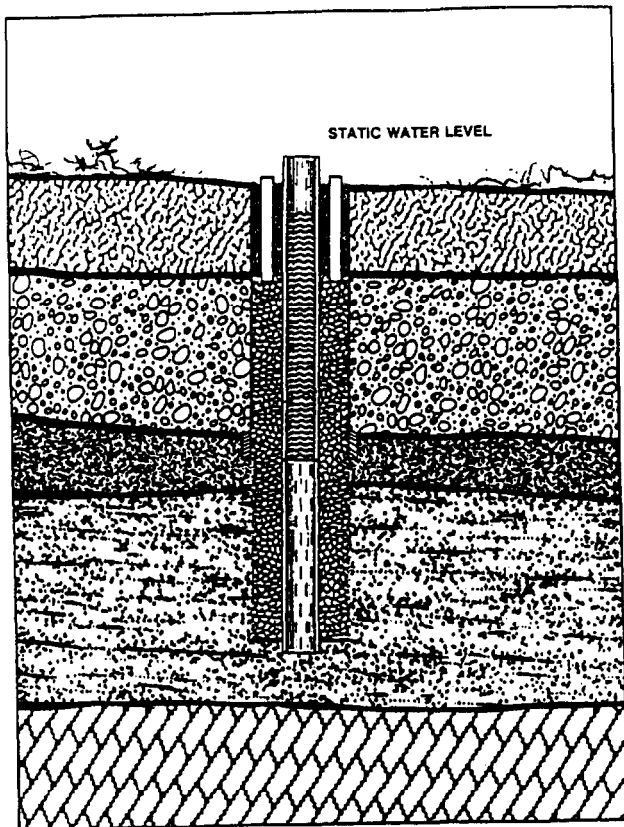

Figure 9-16.-Gravel pack.

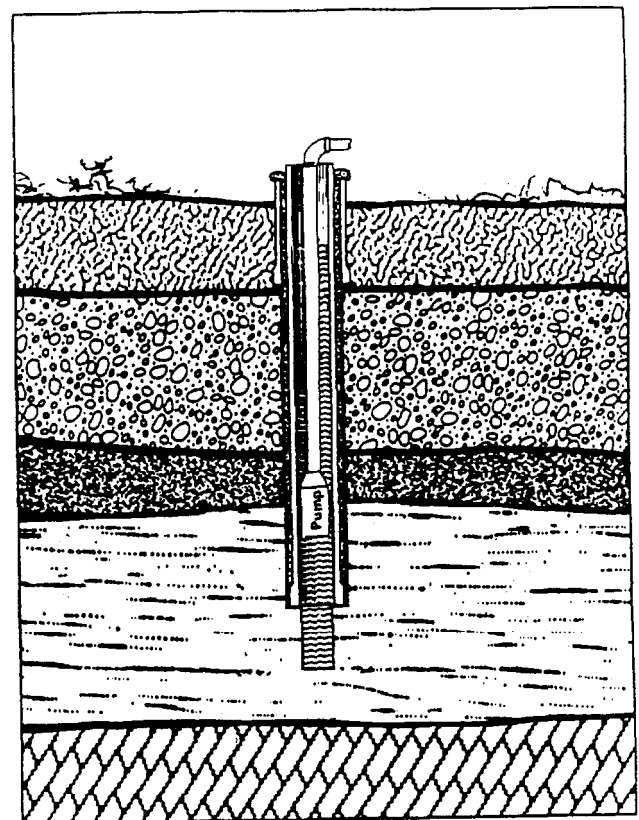

Figure 9-17.-Capped well.

3. When working in the mast, safety belts should be worn, and tools should be securely attached to the belts by lines.

4. Before ascending, safety shoes should be cleaned of all mud and footholds inspected for grease. Wearing of safety shoes with reinforced tops will protect toes from being crushed when working with drilling tools.

5. Sheave guards should remain over all moving gears and chain drives.

6. Personnel should not wear loose or flapping clothes.

7. The drilling table, or platform, should be kept free of loose tools, both to prevent accidents to personnel and loss of tools down the drilled hole. The platform should also be kept clean and dry as possible.

8. Do not attempt to lube or adjust moving gears.

9. When hoisting loads, do not place yourself between any moving part and stationary object.

10. Stay clear of suspended loads.

11. Repair or replace all parts that need repair as needed.

APPENDIX I

CONVERSION TABLES

MULTIPLY	BY	TO OBTAIN	MULTIPLY	BY	TO OBTAIN
Acres	43,560	square feet	Cubic inches	1.639×10^{-5}	cubic meters
Acres	4047	square meters	Cubic inches	2.143×10^{-5}	cubic yards
Acres	1.562×10^{-3}	square miles	Cubic inches	4.329×10^{-2}	gallons
Acres	5645.38	square yards	Cubic inches	1.639×10^{-2}	liters
Acres	4840	square yards	Cubic inches	0.03463	pints (liq)
Board-foot	0.2530	cubic inches	Cubic inches	0.01732	quarts (liq)
British thermal units	144 sq. in. \times 1 in.	kilogram-calories	Cubic meters	10^4	cubic centimeters
British thermal units	777.5	foot-pounds	Cubic meters	35.31	cubic feet
British thermal units	3.927×10^{-4}	horsepower-hours	Cubic meters	81.023	cubic inches
British thermal units	1054	joules	Cubic meters	1.303	cubic yards
British thermal units	107.5	kilogram-meters	Cubic meters	264.2	gallons
British thermal units	2.928×10^{-4}	kilowatt-hours	Cubic meters	10^2	liters
Btu per min	12.96	foot-pounds per sec	Cubic meters	2113	pints (liq)
Btu per min	0.2356	horsepower	Cubic meters	1057	quarts (liq)
Btu per min	0.01757	kilowatts	Cubic yards	7.646×10^5	cubic centimeters
Btu per min	17.57	watts	Cubic yards	27	cubic feet
Btu per sq ft per min	0.1220	watts per square inch	Cubic yards	46.656	cubic inches
Centiliters	0.01	liters	Cubic yards	0.7646	cubic meters
Centimeters	0.3937	inches	Cubic yards	202.0	gallons
Centimeters	0.01	meters	Cubic yards	764.6	liters
Centimeters	393.7	mils	Cubic yards	1616	pints (liq)
Centimeters	10	millimeters	Cubic yards	807.9	quarts (liq)
Cubic centimeters	3.531×10^{-3}	cubic feet	Cubic yards per minute	0.45	cubic feet per second
Cubic centimeters	6.102×10^{-2}	cubic inches	Cubic yards per minute	3.367	gallons per second
Cubic centimeters	10^{-6}	Cubic meters	Cubic yards per minute	12.74	liters per second
Cubic centimeters	1.306×10^{-6}	cubic yards	Days	24	hours
Cubic centimeters	2.642×10^{-4}	gallons	Days	1440	minutes
Cubic centimeters	10^{-2}	liters	Days	86,400	seconds
Cubic centimeters	2.113×10^{-3}	pints (liq)	Fathoms	6	feet
Cubic centimeters	1.057×10^{-3}	quarts (liq)	Feet	30.48	centimeters
Cubic feet	2.832×10^6	cubic cms	Feet	12	inches
Cubic feet	1728	cubic inches	Feet	0.3048	meters
Cubic feet	0.02832	cubic meters	Feet	.36	yards
Cubic feet	0.03704	cubic yards	Feet	1/3	yards
Cubic feet	7.481	gallons	Feet of water	0.02950	atmosphere
Cubic feet	28.32	liters	Feet of water	0.8826	inches of mercury
Cubic feet	59.84	pints (liq)	Feet of water	304.8	kgs per square meter
Cubic feet	29.92	quarts (liq)	Feet of water	62.43	pounds per sq ft
Cubic feet per minute	472.0	cubic cms per sec	Feet of water	0.4335	pounds per sq inch
Cubic feet per minute	0.1247	gallons per sec	Foot-pounds	1.286×10^{-3}	British thermal units
Cubic feet per minute	0.4720	liters per second	Foot-pounds	1.356×10^7	ergs
Cubic feet per minute	82.4	lbs of water per min	Foot-pounds	5.050×10^{-7}	horsepower-hours
Cubic feet per minute	16.39	cubic centimeters	Foot-pounds	1.356	joules
Cubic inches	5.787 \times 10^{-4}	cubic feet	Foot-pounds	3.241×10^{-4}	kilogram-calories
Cubic inches			Foot-pounds	0.1383	kilogram-meters

MULTIPLY	BY	TO OBTAIN	MULTIPLY	BY	TO OBTAIN
Foot-pounds	3.766×10^{-7}	kilowatt-hours	Kilometers	0.6214	miles
Gallons	3785	cubic centimeters	Kilometers	1093.6	yards
Gallons	0.1337	cubic feet	Kilowatts	56.92	Btu per min
Gallons	231	cubic inches	Kilowatts	4.425×10^2	foot-pounds per min
Gallons	3.785×10^{-3}	cubic meters	Kilowatts	737.6	foot-pounds per sec
Gallons	4.951×10^{-3}	cubic yards	Kilowatts	1.341	horsepower
Gallons	3.785	liters	Kilowatts	14.34	kg.-calories per min
Gallons	8	pints (liq)	Kilowatts	10^3	watts
Gallons	4	quarts (liq)	Liters	10^2	cubic centimeters
Horse-power	42.44	Btu per min	Liters	0.03531	cubic feet
Horse-power	33,000	foot-pounds per min	Liters	61.02	cubic inches
Horse-power	550	foot-pounds per sec	Liters	10^3	cubic meters
Horse-power	1.014	horsepower (metric)	Liters	1.308×10^{-2}	cubic yards
Horse-power	10.70	kg.-calories per min	Liters	0.2642	gallons
Horse-power	0.7457	kilowatts	Liters	2.113	pints (liq)
Horse-power	745.7	watts	Liters	1.057	quarts (liq)
Horse-power (boiler)	33.520	Btu per hour	Meters	100	centimeters
Horse-power (boiler)	9.804	kilowatts	Meters	3.2808	feet
Horse-power-hours	2547	British thermal units	Meters	39.37	inches
Horse-power-hours	1.98×10^4	foot-pounds	Meters	10^{-3}	kilometers
Horse-power-hours	2.684×10^4	joules	Meters	10^3	millimeters
Horse-power-hours	641.7	kilogram-calories	Meters	1.0936	yards
Horse-power-hours	2.737×10^4	kilogram-meters	Meter-kilograms	9.807×10^7	centimeter-dynes
Horse-power-hours	0.7457	kilowatt-hours	Miles	1.609×10^3	centimeters
Hours	60	minutes	Miles	5280	feet
Hours	3600	seconds	Miles	1.6093	kilometers
Inches	2.540	centimeters	Miles	1760	yards
Inches	10^4	mils	Miles	1900.8	yards
Inches	.03	yards	Ounces	8	drams
Inches of mercury	0.03342	atmospheres	Ounces	437.5	grains
Inches of mercury	1.133	feet of water	Ounces	28.35	grams
Inches of mercury	345.3	kgs per square meter	Ounces	0.0625	pounds
Inches of mercury	70.73	pounds per square ft	Ounces (fluid)	1.805	cubic inches
Inches of mercury	0.4912	pounds per square in	Ounces (fluid)	0.02957	liters
Inches of water	0.002458	atmospheres	Ounces (troy)	480	grains (troy)
Inches of water	0.07355	inches of mercury	Ounces (troy)	31.10	grams
Inches of water	25.40	kgs per square meter	Ounces (troy)	20	pennyweights troy
Inches of water	0.5781	ounces per square in	Ounces (troy)	0.08333	pounds (troy)
Inches of water	5.204	pounds per square ft	Ounces per sq inch	0.0625	pounds per sq inch
Inches of water	0.03613	pounds per square in	Pounds	7000	grains
Joules	9.486×10^{-4}	British thermal units	Pounds	453.6	grams
Kilograms	10^3	grams	Pounds	16	ounces
Kilograms	70.93	poundals	Pounds	32.17	poundals
Kilograms	2.2046	pounds	Pounds (troy)	0.8229	pounds (av)
Kilograms	1.102×10^{-2}	tons (short)	Pounds of water	0.01602	cubic feet
Kilometers	3281	feet	Pounds of water	27.68	cubic inches
Kilometers	10^7	meters	Pounds of water	0.1198	gallons

APPENDIX II

MATH FORMULAS

MATH FORMULAS

A. WEIGHTS AND MEASURES

Dry Measure

- 2 cups = 1 pint (pt)
- 2 pints = 1 quart (qt)
- 4 quarts = 1 gallon (gal)
- 8 quarts = 1 peck (pk)
- 4 pecks = 1 bushel (bu)

Liquid Measure

- 3 teaspoons (tsp) = 1 tablespoon (tbsp)
- 16 tablespoons = 1 cup
- 2 cups = 1 pint
- 16 fluid ounces (oz) = 1 pint
- 2 pints = 1 quart
- 4 quarts = 1 gallon
- 31.5 gallons = 1 barrel (bbl)
- 231 cubic inches = 1 gallon
- 7.48 gallons = 1 cubic foot (cu ft)

Weight

- 16 ounces = 1 pound (lb)
- 2,000 pounds = 1 short ton (T)
- 2,240 pounds = 1 long ton

Distance

- 12 inches = 1 foot (ft)
- 3 feet = 1 yard (yd)
- 5 1/2 yards = 1 rod (rd)
- 16 1/2 feet = 1 rod
- 1,760 yards = 1 statute mile (mi)
- 5,280 feet = 1 statute mile

Area

- 144 square inches = 1 square foot (sq ft)
- 9 square feet = 1 square yard (sq yd)
- 30 1/4 square yards = 1 square rod
- 160 square rods = 1 acre (A)
- 640 acres = 1 square mile (sq mi)

Volume

- 1,728 cubic inches = 1 cubic foot (cu ft)
- 27 cubic feet = 1 cubic yard (cu yd)

Counting Units

- 12 units = 1 dozen (doz)
- 12 dozens = 1 gross
- 144 units = 1 gross
- 24 sheets = 1 quire
- 480 sheets = 1 ream

Equivalents

- 1 cubic foot of water weighs 62.5 pounds (approx) = 1,000 ounces
- 1 gallon of water weighs 8 1/3 pounds (approx)
- 1 cubic foot = 7.48 gallons
- 1 inch = 2.54 centimeters
- 1 foot = 39.48 centimeters
- 1 meter = 39.37 inches
- 1 liter = 1.05668 quarts (liquid) = 0.90808 quart (dry)
- 1 nautical mile = 6,080 feet (approx)
- 1 fathom = 6 feet
- 1 shot of chain = 15 fathoms

B. MATHEMATICAL SYMBOLS

Symbol	Name or Meaning	
+	Addition or positive value	
-	Subtraction or negative value	
±	Positive or negative value	
·	Multiplication dot (Centered; not to be mistaken for decimal point.)	
x	Multiplication symbol	
()	Parentheses	
[]	Brackets	
{ }	Braces	
—	Vinculum (overscore)	
	} Grouping Symbols	
%		Percent
÷		Division symbol
:		Ratio symbol
::	Proportion symbol	
=	Equality symbol	
≠	“Not equal” symbol	
<	Less than	
≤	Less than or equal to	
>	Greater than	
≥	Greater than or equal to	

Symbol	Name or Meaning
√	Square root symbol
√	Square root symbol with vinculum. Vinculum is made long enough to cover all factors of the number whose square root is to be taken.
π	Pi. The ratio of the circumference of any circle to its diameter. Approximate numerical value is 22/7 or 3.14

C. GEOMETRIC FORMULAS

(Area, Perimeter, Volume, Surface Area)

In the geometric formulas listed in this appendix, the following letter designations are used except as noted otherwise:

a, b, c, d, and e denote lengths of sides

h denotes perpendicular height

s denotes slant height

A denotes area (plane figures)

C denotes circumference

D denotes diameter

L denotes lateral area (lateral area)

P denotes perimeter

R denotes radius

S denotes surface area (solid figures)

V denotes volume

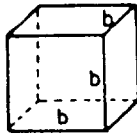

CUBE

$$V = b^3$$

$$S = 6b^2$$

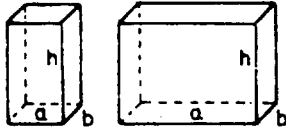

RIGHT RECTANGULAR PRISMS

$$V = abh$$

$$S = 2ab + 2ah + 2bh$$

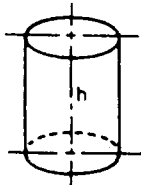

RIGHT CIRCULAR

$$V = \pi R^2 h$$

$$L = 2\pi R h$$

$$S = 2\pi R^2 + 2\pi R h$$

$$S = 2(\text{AREA OF BASE}) + (\text{CIRCUMFERENCE} \times \text{HEIGHT})$$

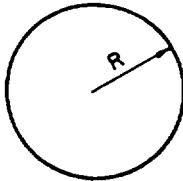

SPHERE

$$V = \frac{4\pi R^3}{3}, \quad V = 0.5236D^3 \text{ (APPROX.)}$$

$$S = 4\pi R^2, \quad S = \pi D^2$$

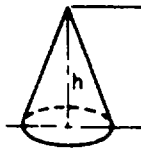

RIGHT CIRCULAR CONE

$$V = \frac{\pi R^2 h}{3}$$

$$L = s\pi R$$

$$S = s\pi R + \pi R^2 \text{ (TOTAL)}$$

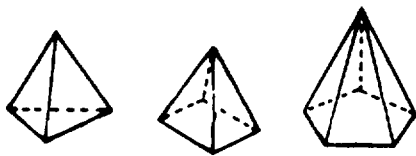

ANY REGULAR RIGHT PYRAMID

$$V = \frac{1}{3} \text{ HEIGHT} \times \text{AREA OF THE BASE}$$

$$L = \frac{1}{2} \text{ SLANT HEIGHT} \times \text{PERIMETER OF THE BASE}$$

NOTE: TO OBTAIN TOTAL SURFACE, ADD AREA OF BASE TO GIVEN SURFACE FORMULA.

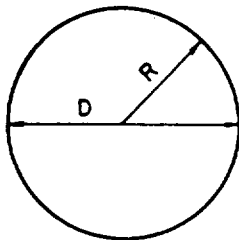

CIRCLE

$$A = \pi R^2, \quad A = \frac{1}{4}\pi D^2$$

$$C = 2\pi R, \quad C = \pi D$$



TRIANGLES

$$A = \frac{bh}{2}$$

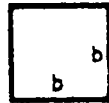

SQUARE

$$A = b^2$$

$$P = 4b$$

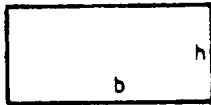

RECTANGLE

$$A = bh$$

$$P = 2b + 2h$$

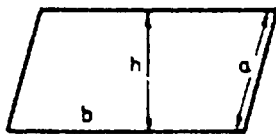

PARALLELOGRAM

$$A = bh$$

$$P = 2a + 2b$$

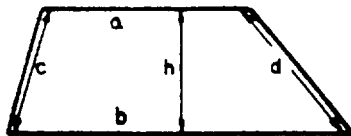

TRAPEZOID

$$A = \frac{h(a+b)}{2}$$

$$P = a + b + c + d$$

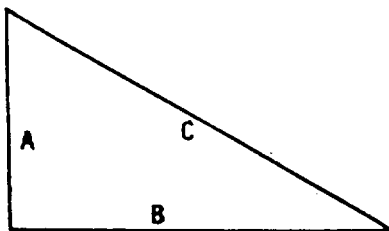

$$C(\text{HYPOTENUSE}) = \sqrt{A^2 + B^2}$$

1. BOARD FEET

$$\frac{\text{NO. OF PCS X THICKNESS (IN.) X WIDTH (IN.) X LENGTH (FT.)}{12}$$

2. CUBIC YARDS

$$\text{THICKNESS } \frac{\text{IN. (OR FT.)}}{36} \text{ X WIDTH } \frac{\text{IN. (OR FT.)}}{36} \text{ X LENGTH } \frac{\text{FT}}{3}$$

**INCHES REDUCED TO DECIMALS
(FOOT)**

INCHES	DECIMALS
1/2	0.041
1	0.083
1 1/2	0.125
2	0.167
2 1/2	0.209
3	0.250
3 1/2	0.292
4	0.333
4 1/2	0.375
5	0.417
5 1/2	0.458
6	0.500
6 1/2	0.542
7	0.583
7 1/2	0.625
8	0.667
8 1/2	0.708
9	0.750
9 1/2	0.792
10	0.833
10 1/2	0.875

INCHES DECIMAL

11	0.917
11 1/2	0.958
12	1.00

**COMMON FRACTIONS STATED
AS DECIMALS**

FRACTION	DECIMAL
1/16	0.0625
1/8	0.125
3/16	0.1875
1/4	0.250
5/16	0.3125
3/8	0.375
7/16	0.4375
1/2	0.500
9/16	0.5625
5/8	0.625
11/16	0.6875
3/4	0.750
13/16	0.8125
7/8	0.875
15/16	0.9375
16/16	1.00

APPENDIX III

REFERENCES

Chapter 1

Construction Mechanic 1, NAVEDTRA 10645-F1, Naval Education and Training Program Management Support Activity, Pensacola, Fla., 1989.

Construction Mechanic 3 & 2, NAVEDTRA 10644-G1, Naval Education and Training Program Management Support Activity, Pensacola, Fla., 1988.

Equipment Management, COMSECOND/COMTHIRDNCB 11200.1 Series, Department of the Navy, Naval Construction Battalions, U.S. Pacific Fleet, Pearl Harbor, Hawaii, Naval Construction Battalions, U.S. Atlantic Fleet, Naval Amphibious Base, Little Creek Norfolk, Va., 1988.

Equipment Management Manual, NAVFAC P-404, Naval Facilities Engineering Command, 200 Stovall Street, Alexandria, Va., 1988.

Equipment Operator 1, NAVEDTRA 10641-H1, Naval Education and Training Program Management Support Activity, Pensacola, Fla., 1989.

Higgins, Lindley R., *Handbook of Construction Equipment Maintenance*, McGraw-Hill Book Company, New York N. Y., 1979.

Management of Transportation, NAVFAC P-300, Naval Facilities Engineering Command, 200 Stovall Street, Alexandria, Va., 1989.

Chapter 2

Embarkation Manual, COMSECOND/COMTHIRDNCBINST 3120.1 Series, Naval Construction Brigade, Pearl Harbor, Hawaii, Naval Amphibious Base, Little Creek, Norfolk Va., 1983.

Initial Outfitting Repair Parts and COSAL Support System, Civil Engineer Support Office (CESO), Construction Battalion Center, Port Hueneme, Calif.

MAC Affiliation Training Program, MAC Pamphlet 50-13, Department of the Air Force, Headquarters Military Airlift Command, Scott Air Force Base, Ill. 1987.

Naval Construction Force/Seabee Chief Petty Officer, NAVEDTRA 10600, Naval Education and Training Program Management Support Activity, Pensacola, Fla., 1989.

NMCB Operations Officer Handbook, COMSECOND/COMTHIRDNCBINST 5200.2A, Naval Construction Brigade, Pearl Harbor, Hawaii, Naval Amphibious Base, Little Creek Norfolk, Va., 1988.

Chapter 3

Cranes, Naval Ships' Technical Manual, S9086-T4-STM-010, Chapter 589, Commander, Naval Sea Systems Command, Washington, D. C., 1988.

Cranes and Attachments 1, SCBT 540.1, Naval Construction Training Center, Gulfport, Miss., 1988.

Cranes and Attachments 2, SCBT 540.2, Naval Construction Training Center, Gulfport, Miss., 1988.

Crane Handbook, Construction Safety Association of Ontario, Toronto, Ontario, Canada, 1982.

Crane & Rigging, Crane Technical Training & Inspection Inc., Altamonte Springs, Fla.

Equipment Operator 1, NAVEDTRA 10641-H1, Naval Education and Training Program Management Support Activity, Pensacola, Fla., 1986.

Equipment Operator 3 & 2, NAVEDTRA 10640-J1, Naval Education and Training Program Management Support Activity, Pensacola, Fla., 1984.

Management of Weight-Handling Equipment Maintenance and Certification, NAVFAC P-307, Naval Facilities Engineering Command, Alexandria, Va., 1989.

Mobile Crane Manual, Construction Safety Association of Ontario, Toronto, Ontario, Canada, 1982.

Rigging Manual, Construction Safety Association of Ontario, Toronto, Ontario, Canada, 1975.

Testing and Licensing of Weight-Handling and Construction Equipment Operators, NAVFAC P-306, Naval Facilities Engineering Command, Alexandria, Va., 1978.

Wire and Fiber Rope and Rigging, Naval Ships' Technical Manual, NAVSEA S9086-UU-STM-000/CH-613, Chapter 613, Commander, Naval Sea System Command, Washington, D.C., 1978.

Chapter 4

Earthwork Principles: Computing Volume, Programmed Instruction Division, U.S. Naval Schools Construction, Port Hueneme, Calif., 1971.

Equipment Operator 1 & C, NAVEDTRA 10641-G, Naval Education and Training Program Management Support Activity, Pensacola, Fla., 1979.

Equipment Operator 3 & 2, NAVEDTRA 10640-J1, Naval Education and Training Program Management Support Activity, Pensacola, Fla., 1984.

Gradework Principles and Road Nomenclature, Programmed Instruction for Equipment Operator, Naval Construction Training Center, Gulfport, Miss.

Naval Construction Force Manual, NAVFAC P-315, Department of the Navy, Naval Facilities Engineering Command, Alexandria, Va., 1983.

Naval Construction Force/Seabee Chief Petty Officer, NAVEDTRA 10600, Naval Education and Training Program Management Support Activity, Pensacola, Fla., 1989.

Naval Construction Force/Seabee Chief Petty Officer First Class, NAVEDTRA 10601, Naval Education and Training Program Management Support Activity, Pensacola, Fla., 1989.

Naval Mobile Construction Battalion Crew Leaders Handbook, Naval Schools, Civil Engineer Corps Officers School, Port Hueneme, Calif., 1985.

Nichols, Herbert L., *Moving the Earth*, North Castle Books Inc., Greenwich, Conn., 1976.

NMCB Operations Officer Handbook, COMSECOND/COMTHIRDNCBINST 5200.2A, Naval Construction Brigade, Pearl Harbor, Hawaii, Naval Amphibious Base, Little Creek, Norfolk, Va., 1988.

Seabee Planner and Estimator Handbook, NAVFAC P-405, Department of the Navy, Naval Facilities Engineering Command, Alexandria, Va., 1985.

Chapter 5

Engineering Aid 3, NAVEDTRA 10696, Naval Education Training Program Management Support Activity, Pensacola, Fla., 1991.

Equipment Operator 1 & C, NAVEDTRA 10641-G1, Naval Education Training Program Management Support Activity, Pensacola, Fla., 1981.

NCF Welding Materials Handbook, NAVFAC P-433, Naval Facilities Engineering Command, Alexandria, Va., 1986.

Quarry Operations 1, U.S. Army Subcourse EN5463, U.S. Army Engineer School, Fort Belvoir, Va., 1989.

Steelworker 3 & 2, NAVEDTRA 10653, Naval Education Training Program Management Support Activity, Pensacola, Fla., 1980.

Chapter 6

Crusher HQ, Universal Engineer Corporation, Cedar Rapids, Iowa, 1982.

Equipment Operator 1 & C, NAVEDTRA 10641-G1, Naval Education Training Program Management Support Activity, Pensacola, Fla., 1981.

Management; Utilization of Engineering Construction Equipment, TM5-331, Department of the Army, Washington, D.C., 1962.

Nichols, Herbert L., *Moving the Earth*, 3rd ed., North Castle Books, INC, Greenwich, Connecticut, 1976.

Quarry Operations II, U.S. Army Subcourse EN5464, U.S. Army Engineer School, Fort Leonard Wood, Mo., 1989.

Chapter 7

Basics of Concrete, Concrete Construction Publication, Inc., Addison, Ill., 1986.

Builder 3 & 2, Volume 1, NAVEDTRA 10646, Naval Education and Training Program Management Support Activity, Pensacola, Fla., 1987.

Design and Control of Concrete Mixture, Portland Cement Association, Ill., 1988.

Engineering Aid 3, NAVEDTRA 10696, Naval Education and Training Program Management Support Activity, Pensacola, Fla., 1991.

CDC 55150 Pavements Maintenance Specialist, Volume 3, Flexible Pavements, Extension Course Institute, Gunter Air Force Base, Ala.

Trailer Mounted Mobile Concrete Mixer Plant, U.S. Navy Service Manual, Zimmerman Industries, Ephrata, Pa., 1987.

Chapter 8

Bituminous Pavements, U.S. Army Subcourse EN5459, U.S. Army Engineer School, Fort Belvoir, Va.

Engineering Aid 3 & 2, Volume 3, NAVEDTRA 10629-1, Naval Education and Training Program Management Support Activity, Pensacola, Fla., 1984.

Equipment Operator 1, NAVEDTRA 10641-H1, Naval Education and Training Program Management Support Activity, Pensacola, Fla., 1986.

Equipment Operator 1 & C, NAVEDTRA 10641-G1, Naval Education and Training Program Management Support Activity, Pensacola, Fla., 1981.

Equipment Operator 3 & 2, NAVEDTRA 10640-J1, Naval Education and Training Program Management Support Activity, Pensacola, Fla., 1984.

Pavement Maintenance Specialist, Volume 3, Flexible Pavements Course 55150, U.S. Air Force Air University, Gunter Air Force Base, Montgomery, Ala.

Principles of Construction of Hot-Mix Asphalt Pavements, The Asphalt Institute Manual, Series No. 22, Asphalt Institute Building, College Park Md., 1983.

Chapter 9

Equipment Operator 1 & C, NAVEDTRA 10641-H, Naval Education Training Program Management Support Activity, Pensacola, Fla., 1986.

Geology, TM 5-545, Department of the Army, Washington, D.C., 1971.

Integrated Logistic Support Plan for the Lightweight Well Drilling Rig System, NAVFAC ILSP 0311, Department of the Navy, Naval Facilities Engineering Command, Alexandria, Va., 1985.

Self-Propelled Prototype Design Lightweight Easily Transported Well Drilling Rig, Ingersall-Rand Research, Inc., Princeton, N. J., 1985.

Water Well Drilling (Failing Rig), SCBT 530.1, Naval Construction Training Center, Gulfport, Miss., 1989.

Well Drilling Operations, TM 5-297/AFM 85-23, Departments of the Army and the Air Force, Washington D.C., 1965.

INDEX

A

- Air detachment, CESE and material preparation, 2-4, 2-6
- Air detachment, CESE requirements, 2-3
- Air detachment, crew assignments, 2-1
- Air detachment equipment supervisor responsibilities, 2-1
 - collateral equipage, 2-14
 - crew assignments, 2-1
 - equipment platoon administration readiness, 2-1 to 2-2
 - equipment platoon operations, 2-15 to 2-16
 - operator assignments, 2-3 to 2-4
 - site arrival, 2-14 to 2-15
 - site selection, 2-14
- Air detachment, mount-out/retrograde, 2-16 to 2-18
- Air detachment, palletized cargo, 2-11 to 2-14
- Air detachment, projects, 2-16
- Air detachment, table of allowance, 2-2 to 2-3
- Air detachment, vehicle shoring, 2-9 to 2-10
- Air detachment, weighing and marking, 2-4 to 2-9
- Apron feeder, 6-2
- Asphalt batch plant, 8-12 to 8-15
 - asphalt introduction, 8-14
 - discharge gate, 8-15
 - plant automation, 8-15
 - pugmill mixing, 8-14
- Asphalt, bituminous surfacing materials, 8-18
- Asphalt, compacted weight and volume, 8-32
- Asphalt, continuous-flow plant, 8-15 to 8-16
 - mixing time, 8-16
 - pugmill mixer, 8-15
- Asphalt, drum-mix plant, 8-16 to 8-18
 - aggregate storage and feed, 8-16 to 8-17
 - asphalt metering, 8-17
 - burner operation, 8-18
 - drum-mix operation, 8-17 to 8-18
 - surge silo, 8-18
- Asphalt, estimation of materials, 8-27
 - compute bituminous material, 8-31 to 8-33
 - estimates for asphalt plants, 8-33
 - prime coat, 8-27 to 8-28
 - surface treatment, 8-30 to 8-31
 - tack coat, 8-28 to 8-29
 - tons per hour, 8-33
- Asphalt, field identification of bituminous materials, 8-23 to 8-24
 - field penetration test, 8-26
 - heat-odor test, 8-26
 - pour test, 8-25
 - smear test, 8-26
 - solubility test, 8-24
 - stone-coating test, 8-26 to 8-27
- Asphalt plant operations, 8-2
 - aggregate cold-feed system, 8-2 to 8-5
 - asphalt heating and circulation, 8-10
 - dryer, 8-5 to 8-6
 - dust collector, 8-6 to 8-8
 - hot bin sampling, 8-9 to 8-10
 - hot bins, 8-9
 - hot screens, 8-8 to 8-9
 - mineral filler, 8-10 to 8-12
 - temperature of mixture, 8-10
- Asphalt plant safety, 8-34
- Asphalt plant supervisor responsibilities, 8-1 to 8-2
- Asphalt temperature ranges, 8-11

Asphalt, types and grades, 8-18

asphalt cements, 8-18 to 8-20

asphalt cutbacks, grades, and uses, 8-20 to 8-21

asphalt emulsions, uses, 8-21 to 8-22

tars, uses, 8-22 to 8-23

B

Battalion Equipment Evaluation Program (BEEP),
1-30 to 1-37

Blasting operations, 5-16

C

Compaction qualities of soil, 5-7 to 5-8

compactive effort, 5-8

material gradation, 5-7

moisture content, 5-7

Computations of asphalt materials, 8-27

bituminous materials, 8-31 to 8-33

prime coat, 8-27 to 8-28

surface treatment, 8-30 to 8-31

tack coat, 8-28 to 8-29

tons per hour, 8-33

Computations of concrete volume, 7-3 to 7-4

Computations of crane test weights, 3-13 to 3-16

Computations of earthwork, 4-4 to 4-11

Computations of equipment, 4-11

Concrete

batching, 7-4

computing volume of, 7-3 to 7-4

mixer cleaning, 7-5

mixing, 7-4

mobile mixer plant, 7-7

overmixing, 7-4 to 7-5

plant safety, 7-8

remixing, 7-5

slump test, 7-7 to 7-8

Concrete-Continued

transit mixer safety, 7-8

water, 7-3

Concrete additives, 7-3

air-entraining, 7-3

retarders, 7-3

Concrete aggregates, 7-2 to 7-3

handling and storage of aggregates, 7-2

Concrete batch plant supervisor responsibilities, 7-1

Construction Automotive Special Equipment/Management Information System (CASE/MIS),
1-3

equipment code (EC), 1-3

Tab A, 1-3

Conveyers, 6-10 to 6-11

incline, 6-11

loading, 6-11

speed, 6-11

Crane crew supervisor responsibilities, 3-1

crane, BEEP, 3-2, 3-7

crane crew, 3-1

crane license program, 3-2

qualifications, 3-1

Crane license program, 3-2

Crane operator's daily inspection, 3-7

hook block inspection, 3-9 to 3-10

sheave inspection, 3-10

wire rope end connections, 3-8 to 3-9

wire rope inspection, 3-7 to 3-8

Crane safety, 3-20

load capacity, 3-20 to 3-21

mishap reporting, 3-21

safe lifting, 3-21

stability, 3-20

training, 3-21

- Crane, test procedures, 3-13
 - extension of certification, 3-20
 - frequency of test, 3-20
 - load test, 3-17 to 3-19
 - load test certification, 3-19 to 3-20
 - no-load test, 3-16 to 3-17
 - test weights, 3-13 to 3-16
- Crusher primary unit, 6-1 to 6-4
- Crusher supervisor responsibilities, 6-1
- D**
- Dual roll crusher, 6-4 to 6-8
- E**
- Earthwork computations, 4-4
 - cross sections, 4-7 to 4-11
 - road nomenclature, 4-7
 - slope ratio, 4-7
 - volume changes, 4-4 to 4-5
- Equipment estimates, 4-11
- Equipment maintenance, Equipment Repair Order (ERO), 1-25 to 1-29
- Equipment maintenance levels, 1-23
 - depot maintenance, 1-23
 - intermediate maintenance, 1-23
 - organization maintenance, 1-23
- Equipment maintenance live storage program, 1-25, 1-30
- Equipment maintenance program, 1-18
 - maintenance inspector, 1-18
 - maintenance supervisor, 1-18
 - preventive maintenance (PM)/cost control clerk(s), 1-18 to 1-22
 - storage of petroleum products, 1-30
 - technical librarian, 1-23
- Equipment maintenance, repair parts, 1-25
 - COSALS, 1-25
 - repair parts common, NAVSUPMOD 97, 1-25
 - repair parts peculiar, NAVSUPMOD 98, 1-25
- Equipment maintenance scheduling, 1-23 to 1-25
 - type a (01) inspection, 1-23
 - type b (02) inspection, 1-23
 - type c (03) inspection, 1-23 to 1-25
- Equipment management instructions, 1-1 to 1-2
 - Equipment Management Manual, NAVFAC P-404, 1-1
 - Management of Transportation Equipment, NAVFAC P-300, 1-1
 - Naval Construction Force Manual, NAVFAC P-315, 1-2
 - NMCB Equipment Management Instruction, COMSECOND/COMTHIRDNCB INST 11200.1, 1-2
- H**
- Hydrocone crusher, 6-4 to 6-8
- J**
- Jaw crusher, 6-1 to 6-4
- L**
- License program, 1-35, 1-37
 - automotive test, 1-44
 - construction equipment operator license, NAVFAC 11260/2, 1-45 to 1-47
 - construction equipment test, 1-44
 - course of instruction, 1-48
 - license application forms, 1-38 to 1-43
 - license cancellation, 1-47
 - license examiner, 1-37
 - license files, 1-47
 - license forms, 1-44 to 1-45
 - license, lost or mutilated, 1-47
 - license renewal, 1-47

License program—Continued

- license suspension and revocation, 1-47
- license test, 1-44
- license upgrading, 1-47
- material-handling equipment test, 1-44
- mishap investigation, 1-48
- performance qualification test, 1-44
- personnel office, 1-47 to 1-48
- physical fitness inquiry form, 1-38, 1-44
- roadmaster, 1-48
- training license, 1-48
- training program, 1-48

M

Maintaining quarry equipment, 6-16

P

Pit operations, 5-11 to 5-13

Pit or quarry site preparation, 5-8 to 5-11

- chute loading ramps, 5-10
- clearing the site, 5-9
- drainage, 5-9
- operations plan, 5-9
- overburden, 5-9
- roads, 5-9

Pits and quarries, 5-1

- compaction qualities of soil, 5-7 to 5-8
- MOH's scale of hardness, 5-3
- pits, 5-1
- quarries, 5-1
- sieve analysis, 5-5 to 5-7
- site selection, 5-1
- soil formation, 5-1 to 5-3
- soil quality, 5-3 to 5-4
- types of quarry material, 5-4 to 5-5

Portland cement, 7-1 to 7-2

- storage of cement, 7-1
- types of cement, 7-1

Project supervisor responsibilities, 4-1

- concepts of construction, 4-2 to 4-3
- deployment planning, 4-3 to 4-4
- NMCB organization, 4-1
- prime contractor/lead company organization, 4-2
- project manager/resource manager organization, 4-2
- self-sufficient unit organization, 4-3

Q

Quarry equipment, 5-15

- maintenance, 5-16
- wearfacing, 5-15 to 5-17

Quarry operations, 5-13

- quarry development, 5-13 to 5-15
- quarry terminology, 5-13

Quarry supervisor responsibilities, 5-1

R

Rock crusher, 6-1

- blocking, 6-3
- bridging, 6-3
- choking, 6-3
- closed circuit crushing system, 6-8
- dual roll crusher, 6-4 to 6-8
- heavy-duty apron type of feeder, 6-2
- hydrocone crusher, 6-4 to 6-8
- packing, 6-3
- primary unit, 6-1 to 6-4
- secondary unit, 6-4 to 6-8

Rock crusher plant layout, 6-13 to 6-15

- plant erection, 6-15 to 6-16

Rock crusher, screens, 6-8 to 6-9

capacity, 6-9

feeding material to screen, 6-9

screen selection, 6-9 to 6-10

variable factors, 6-9

Rock crusher, secondary unit, 6-4 to 6-8

Rock crusher, wash plant, 6-11 to 6-12

Rotary well drilling, 9-4 to 9-9

kelly-drive drilling, 9-9 to 9-10

top-head drive drilling, 9-10 to 9-13

S

Safety

asphalt plant, 8-34

concrete plant, 7-8

concrete transit mixer, 7-8

cranes, 3-20 to 3-21

well drilling, 9-16 to 9-17

wire rope, 3-23 to 3-26, 3-32 to 3-33

Sieve analysis, 5-5 to 5-7

Slings, wire rope sling and rigging hardware, 3-21 to 3-22

bridle hitch, 3-23

eye splice, 3-26 to 3-28

single-vertical hitch, 3-22 to 3-23

sling, 3-22

sling angle, 3-23

sling inspection, 3-30 to 3-32

sling, proof testing, 3-28 to 3-30

sling and rigging gear kits, 3-30

sling, records, 3-30

sling, safe working loads, 3-23 to 3-26

sling, storage, 3-30

sling, wire rope lubrication, 3-32

sling, wire rope maintenance, 3-32

sling, wire rope safe operating procedures, 3-32 to 3-33

Supervisor responsibilities

asphalt plant, 8-1 to 8-2

concrete batch plant, 7-1

crusher, 6-1

projects, 4-1

quarry, 5-1

transportation, 1-1

well drilling, 9-1

T

Transportation supervisor responsibilities, 1-1

attachment custodian, 1-16

bus service, 1-18

category of assignments, 1-9 to 1-10

CESE assignments, 1-9

Collateral Custodian Record Card, COM-SECOND/COMTHIRDNCB 60 form, 1-14

collateral equipage, 1-13

collateral equipage custodian, 1-13 to 1-16

component collateral equipage, 1-13

dispatcher, 1-3

dispatcher logs, 1-4 to 1-8

equipment availability, 1-13

equipment cycling, 1-12

equipment request, 1-9, 1-11 to 1-12

equipment status board, 1-3 to 1-4

fuel operations, 1-16 to 1-17

maintenance field crew operations, 1-18

PM-to-interim repair ratio, 1-12 to 1-13

preventive maintenance, 1-12

tactical collateral equipage, 1-13

tool kit, 1-12

tractor-trailer operations, 1-17

trouble reports file (hard-card file), 1-9

washing of CESE, 1-12

yard boss, 1-12

W

Well development and completion, 9-15 to 9-16

Well drilling difficulties, 9-13 to 9-14

 crooked holes, 9-14

 fishing, 9-15

 recovery of stuck drill pipe, 9-14 to 9-15

Well drilling safety, 9-16 to 9-17

Well drilling supervisor responsibilities, 9-1

 groundwater exploration, 9-3 to 9-4

 kelly-drive rotary drilling operations, 9-9 to 9-10

 mud pits, 9-9

 rotary drilling, 9-4 to 9-6

 rotary drilling bits, 9-9

 rotary drilling crew, 9-6 to 9-9

 top-head drive rotary well drilling, 9-10 to 9-13

 types of wells, 9-4

 water sources, 9-1 to 9-3

Assignment Questions

Information: The text pages that you are to study are provided at the beginning of the assignment questions.

NAVAL EDUCATION AND TRAINING PROGRAM
MANAGEMENT SUPPORT ACTIVITY
PENSACOLA, FLORIDA 32509-5000

Errata #1

OCT 1995

Specific Instruction and Errata for
Nonresident Training Course

EQUIPMENT OPERATOR ADVANCED

1. TO OBTAIN CREDIT FOR DELETED QUESTIONS, SHOW THIS ERRATA TO YOUR LOCAL COURSE ADMINSTRATOR (ESO/SCORER). THE LOCAL COURSE ADMINISTRATOR (ESO/SCORER) IS DIRECTED TO CORRECT THE ANSWER KEY FOR THIS COURSE BY INDICATING THE QUESTIONS DELETED.
2. This errata supersedes all previous errata. No attempt has been made to issue corrections for errors in typing, punctuation, etc. which are obvious to the enrollee and do not affect the student's ability to answer the questions.
3. Assignment Booklet,

Delete the following questions and write "Deleted" across all four of the boxes for that question.

Question

6-41

ASSIGNMENT 1

Textbook Assignment: "Transportation Supervisor," pages 1-1 through 1-17.

Learning Objective: Identify the commands that are responsible for the procurement and management of equipment.

Learning Objective: Identify the management instructions used for the management and control of equipment.

- 1-1. What does the acronym CESE mean?
1. Civil Engineer Supply Equipment
 2. Civil Engineer Shore Equipment
 3. Civil Engineer Seabee Equipment
 4. Civil Engineer Support Equipment

- 1-2. CESE is classified as what type of material?
1. 1C
 2. 2C
 3. 3C
 4. 4C

- 1-3. What command is assigned the inventory manager responsibility for all 2C material in the Navy?
1. COMSECONDNCB Det Gulfport
 2. COMTHIRDNCB Det Port Hueneme
 3. NAVFACENGCOM
 4. CESO

- 1-4. What does the acronym CESO mean?
1. Civil Engineer Seabee Office
 2. Civil Engineer Shore Office
 3. Civil Engineer School Office
 4. Civil Engineer Support Office

- 1-5. The management responsibility for 2C materials is assigned to what command?
1. CESO
 2. CECOC
 3. COMTHIRDNCB Det Port Hueneme
 4. COMSECONDNCB Det Gulfport

- 1-6. What manual provides guidance for the management of equipment in a stable environment?

1. NAVFAC P-307
2. NAVFAC P-300
3. NAVFAC P-306
4. NAVFAC P-404

- 1-7. What manual is a compilation of directives issued by the SECNAV, CNO, and COMNAVFACENGCOM?

1. NAVFAC P-307
2. NAVFAC P-306
3. NAVFAC P-300
4. NAVFAC P-404

- 1-8. Procedures for the administration, operation, and maintenance of transportation equipment are contained in which of the following manuals?

1. NAVFAC P-405
2. NAVFAC P-306
3. NAVFAC P-307
4. NAVFAC P-300

- 1-9. Criteria, policies, and procedures for the management of CESE assigned to Special Operating Units are contained in which of the following manuals?

1. NAVFAC P-404
2. NAVFAC P-306
3. NAVFAC P-405
4. NAVFAC P-307

- 1-10. What manual or instruction was developed for the management of equipment in a variety of extreme conditions?
1. COMSECOND/ COMTHIRDCBINST 11200.1 series
 2. NAVFAC P-404
 3. NAVFAC P-405
 4. NAVFAC P-437
- 1-11. Policies and procedures to assist personnel concerned with the management of equipment within the Naval Construction Brigades are contained in which of the following instructions?
1. COMSECOND/COMTHIRDNCBINST 11200.1 series
 2. COMSECOND/ COMTHIRDNCBINST 11200.2 series
 3. COMSECOND/COMTHIRDNCBINST 11200.3 series
 4. COMSECOND/COMTHIRDNCBINST 11200.4 series
- 1-12. What manual or instruction has the intent to assist all levels of personnel in the management of transportation/maintenance operations?
1. NAVFAC P-437
 2. NAVFAC P-405
 3. COMSECOND/ COMTHIRDNCBINST 11200.1 series
 4. COMSECOND/ COMTHIRDNCBINST 11200.41 series
- 1-13. The Chief of Civil Engineers provides technical guidance regarding the organization and operation of the NCF in which of the following manuals?
1. NAVFAC P-405
 2. NAVFAC P-315
 3. NAVFAC P-437
 4. NAVFAC P-306
- 1-14. What manual presents an overview of the NCF and describes the mission and concepts of operations for NCF units other than the NMCB?
1. NAVFAC P-306
 2. NAVFAC P-307
 3. NAVFAC P-405
 4. NAVFAC P-315
-
- Learning Objective: Identify the programs and formats used for the management and control of equipment.
-
- 1-15. Which of the following computer programs is used for the management and procurement of CESE?
1. CASE/MIS
 2. ENABLE
 3. SAMMS
 4. WP 5.1
- 1-16. The COMSECOND/COMTHIRDNCB Equipment Offices perform on-hands management of CESE assignments, replacements, and overhauls on what computer program?
1. ENABLE
 2. CASE/MIS
 3. WP 5.1
 4. FORM TOOL
- 1-17. What type of list is a TAB A?
1. Supply list
 2. Parts list
 3. Weapons list
 4. Equipment list
- 1-18. The TAB A is initiated by what office?
1. Civil Engineer Support Office
 2. COMSECOND/COMTHIRDNCB Equipment Office
 3. Alfa company operations office
 4. Alfa company maintenance office

- 1-19. The equipment code (EC) for each type of CESE is assigned by what command?
1. NMCB
 2. CED
 3. CESO
 4. NCTC
- 1-20. Any special procurement for a unit of CESE is designated by which of the following numbers in the equipment code?
1. The first number
 2. The first two numbers
 3. The last number
 4. The last two numbers
- 1-21. The Naval Supply Systems Command controls the inventory of equipment by what equipment codes?
1. 0001/00-0999/99
 2. 1000/00-1999/00
 3. 2000/00-9999/99
 4. 10000/00-99999/99
-
- Learning Objective: Identify the responsibilities of the dispatcher.
-
- 1-22. The status and location of every assigned item of equipment is controlled by which of the following personnel?
1. Operations chief
 2. Transportation supervisor
 3. Yard boss
 4. Dispatcher
- 1-23. All spare keys for CESE are maintained in which of the following locations?
1. Dispatcher history jacket
 2. Dispatchers field jacket
 3. Equipment history jacket
 4. Seabee field jacket
- 1-24. The primary function of the equipment status board is to serve as a visual aid that provides a list of all equipment assigned to the unit.
1. True
 2. False
- 1-25. In the legend on the equipment status board in figure 1-2, the color green denotes which of the following information?
1. In-service, operational
 2. Deadline
 3. Pending replacement
 4. Ordered in
- 1-26. The dispatcher makes comparison checks daily between the dispatch equipment status board and the equipment status board maintained in what location?
1. Collateral equipage
 2. Crane shed
 3. Cost control
 4. Paint shop
- 1-27. The dispatcher records and maintains information on all vehicles and equipment in which of the following logs?
1. NAVFAC 9-11240/1
 2. NAVFAC 9-11240/2
 3. NAVFAC 9-11240/3
 4. NAVFAC 9-11240/4
- 1-28. Guidelines for dispatch operations are outlined in which of the following instructions?
1. COMSECOND/COMTHIRDNCBINST 11200.1 series
 2. COMSECOND/COMTHIRDNCBINST 1500.20 series
 3. COMSECOND/COMTHIRDNCBINST 5100.1 series
 4. COMSECOND/COMTHIRDNCBINST 5600.1 series

- 1-29. In the NCF, dispatch logs are retained on file for a minimum of how many days?
1. 60
 2. 70
 3. 80
 4. 90
- 1-30. At a public works unit, the DD Form 1970 is retained for a minimum of how many days?
1. 60
 2. 70
 3. 80
 4. 90
- 1-31. At a public works unit, the dispatcher logs are retained for a minimum of how many months?
1. 35
 2. 36
 3. 37
 4. 38
- 1-32. The Trouble Reports File is maintained by what sequence?
1. USN Numbers
 2. Equipment Codes
 3. Julian date of reports
 4. Preventive maintenance intervals
- 1-33. The standard interval between PM service inspections for NCF equipment is a total of how many working days?
1. 20
 2. 30
 3. 40
 4. 50
- 1-34. When a piece of equipment is scheduled for a PM, the cards in what file are forwarded with the piece of equipment?
1. Trouble Reports File
 2. Equipment Request File
 3. PM Schedule File
 4. Dispatcher's File
- 1-35. Within an NMCB, when should the deployment CESE assignments be generated?
1. During the BEEP
 2. Just after the BEEP
 3. Just after the main body arrives
 4. During the home port period
- 1-36. To develop the deployment CESE assignments, you must use what TAB as a guide for ECs and USN numbers?
1. TAB A
 2. TAB B
 3. TAB C
 4. TAB D
- 1-37. Class A assignment of a vehicle can only be authorized by what person?
1. The commanding officer
 2. The alfa company commander
 3. CNO
 4. The command master chief
- 1-38. Class B assigned vehicles should not exceed what percentage of active assigned CESE?
1. 05%
 2. 10%
 3. 15%
 4. 25%
- 1-39. What area in an NMCB provides maximum control over CESE?
1. The barracks
 2. The club
 3. The jobsite
 4. The transportation pool
- 1-40. What person has the final approval for CESE assignments for a NMCB?
1. The alfa company operations chief
 2. The alfa company chief
 3. The battalion operations officer
 4. The battalion commanding officer

- 1-41. During a deployment, what person evaluates and balances the mileage and hours put on assigned CESE?
1. The alfa company commander
 2. The transportation supervisor
 3. The yard boss
 4. The maintenance supervisor
- 1-42. The base station for taxi service should be controlled at which of the following locations?
1. The quarterdeck
 2. The galley
 3. The dispatch office
 4. The barracks
- 1-43. One of the missions of the transportation supervisor is to ensure a maximum service life for the equipment.
1. True
 2. False
-
- Learning Objective: Identify the responsibilities of the yard boss.
-
- 1-44. The yard boss enforces which of the following procedures?
1. Bravo company maintenance
 2. Mechanic maintenance
 3. Operator maintenance
 4. Mishap maintenance
- 1-45. The yard boss is NOT responsible for which of the following actions?
1. Traffic flow
 2. Refueling facility
 3. Maintaining the washrack
 4. Inventory of collateral equipage
- 1-46. The NCF Table of Allowance (TOA) contains which of the following tool kits to support the yard boss program?
1. Kit 80013
 2. Kit 80031
 3. Kit 80107
 4. Kit 80111
- 1-47. What person maintains the hard card log book and issues the hard card numbers?
1. The yard boss
 2. The dispatcher
 3. The collateral equipage custodian
 4. The maintenance supervisor
- 1-48. The equipment cycle log is maintained by which of the following personnel?
1. The yard boss
 2. The light shop supervisor
 3. The heavy shop supervisor
 4. The 5000 shop supervisor
- 1-49. Cycling of equipment should be accomplished at what intervals?
1. Daily
 2. Weekly
 3. Every two weeks
 4. Monthly
- 1-50. Part of the preventive maintenance program is the monthly cleaning of CESE that allows the detection and prevention of major problems.
1. True
 2. False
- 1-51. The cleaning of CESE provides extended equipment life and increased efficiency of operators when they preform pre and post operational checks.
1. True
 2. False
- 1-52. Which of the following terms best identifies an interim repair?
1. First echelon maintenance
 2. Scheduled maintenance
 3. Unscheduled maintenance
 4. Scheduled PM maintenance

- 1-53. COMSECOND/ COMTHIRDNCB Equipo has established what standard PM-to-interim repair ratio?
1. One scheduled PM inspection to each interim repair
 2. Two scheduled PM inspections to each interim repair
 3. Three scheduled PM inspections to each interim repair
 4. Four scheduled PM inspections to each interim repair
- 1-54. The first step to take to achieve the PM-to-interim repair ratio is enforcement of what type of maintenance?
1. Operator maintenance
 2. Mechanic maintenance
 3. Camp maintenance
 4. Yard maintenance
- 1-55. At what time(s) should the transportation supervisor always be sure to tour the equipment yard?
1. First thing in the morning
 2. Last thing at night
 3. During pre and post operations
 4. During the lax period of the day and last thing at night
- 1-56. What person is responsible for changing a burned out taillight?
1. The mechanic at the quick-fix shop
 2. The yard boss
 3. The collateral equipage custodian
 4. The operator of the equipment
- 1-57. Equipment availability is the percentage of time the equipment is available in the mechanic shop compared to deadline.
1. True
 2. False
- 1-58. Which of the following is NOT a result of poor equipment availability?
1. Overworked or abused equipment
 2. Inadequate parts support
 3. Shortage of mechanic
 4. A strong yard boss program
-
- Learning Objective: Identify the responsibilities required to supervise collateral equipage operations.
-
- 1-59. What person approves the ordering of collateral equipage?
1. The maintenance supervisor
 2. The transportation supervisor
 3. The cost control clerk
 4. The collateral equipage custodian
- 1-60. What are the two basic types of collateral equipment?
1. Component and automotive
 2. Construction and automotive
 3. Component and tactical
 4. Construction and tactical
- 1-61. Which of the following is/are NOT a piece of tactical collateral equipage?
1. Bits for the earth auger
 2. Side racks
 3. Lug wrench
 4. Chains with hooks
- 1-62. Outstanding requisitions, receipts, issues, locations, and annotations of allowance of a particular line item of equipage for each CESE is documented on which of the following forms?
1. CB 40
 2. CB 50
 3. CB 60
 4. CB 70

1-63. On the PM date, what form is pulled from a file to perform an inventory of mounted or stored collateral equipage for each USN numbered CESE entering the shop?

1. CB 40
2. CB 50
3. CB 60
4. CB 70

1-64. What person signs the CB 60 form to assume custody of mounted collateral gear on Class C assigned CESE?

1. The transportation supervisor
2. The yard boss
3. The collateral equipage custodian
4. The dispatcher

1-65. Attachments are accessories to automotive equipment that enable the basic equipment to function correctly or to add versatility.

1. True
2. False

1-66. Stored attachment accessories are maintained by what number series?

1. NAVSUP number
2. Equipment code
3. USN number
4. API number

1-67. The segregated storage of all attachments and their associated accessories is the responsibility of what person?

1. The transportation supervisor
2. The dispatcher
3. The yard boss
4. The attachment custodian

1-68. Which of the following designators is NOT reflected on the Attachment Status Board?

1. The attachment code
2. The equipment code
3. The NAVFAC I.D. number
4. Attachment description

Learning Objective: Identify the responsibilities of personnel assigned to conduct fuel operations.

1-69. A poorly managed fuel program results in needless downtime of equipment and delays in production.

1. True
2. False

1-70. What should the fuel truck driver review to determine the location of all CESE?

1. The attachment status board
2. The equipment status board
3. The hard card log book
4. The equipment status log book

1-71. Records of fuel issues are maintained by which of the following personnel?

1. The field maintenance crew
2. The yard boss
3. The fuel truck driver
4. The dispatcher

1-72. The fuel truck driver maintains the fuel truck by the standards outlined in which of the following COMSECON/COMTHIRDNCB instructions?

1. 4400.3 series
2. 11200.11 series
3. 11200.1 series
4. 5600.1 series

1-73. Lettering for the words NO SMOKING is marked on the fuel tanker in what size and color?

1. 6-inch black lettering
2. 6-inch yellow lettering
3. 3-inch black lettering
4. 3-inch yellow lettering

1-74. For fire extinguishers on fuel tankers, COMSECOND/COMTHIRDNCB Equipo recommends you follow the guidelines set forth in which of the following manuals?

1. EM 385-1-1
2. TM 5-545
3. EN 5462
4. EN 0113

1-75. At least one fire extinguisher carried on a fuel truck should be no less than what size?

1. 10-B:C
2. 20-B:C
3. 30-B:C
4. 40-B:C

ASSIGNMENT 2

Textbook Assignment: "Transportation Supervisor", pages 1-17 through 1-37.

Learning Objective: Identify the responsibilities of the transportation supervisor when supervising tractor-trailer operations.

2-1. During a deployment, the hauling of equipment for the PM program and of construction supplies generate thousands of miles of tractor-trailer operations.

1. True
2. False

2-2. What person assigns inexperienced operators with experienced operators for training to become future replacements?

1. The collateral equipage custodian
2. The dispatcher
3. The transportation supervisor
4. The maintenance supervisor

2-3. The operational pace slows which can result in a reduced level of professionalism during what period of time?

1. Pre-deployment
2. Mid-deployment
3. Deployment
4. Homeport

2-4. Height and width limitations of loads are set by what agency?

1. Congress
2. Each state
3. The Highway patrol
4. The local police

2-5. The size of name plates for tractors is constructed as outlined in the COMSECOND/COMTHIRDNCBINST 11200.1 Series at what dimensions?

1. 3 inches high by 18 inches long
2. 3 1/2 inches high by 18 inches long
3. 3 1/2 inches long by 17 inches high
4. 3 inches high by 17 inches long

2-6. The load on every vehicle must be distributed, chocked, tied down, or otherwise secured according to what U.S. Army Manual?

1. EN 5478
2. EN 5258
3. TM 5-331
4. EM 385-1-1

2-7. The safe operation and the securing of cargo on tractor trailers is the responsibility of which of the following personnel?

1. The transportation supervisor
2. The co-rider
3. The operator
4. The yard boss

Learning Objective: Identify the responsibilities of the transportation supervisor when supervising bus and field crew operations.

2-8. The number of CESE on the road can be reduced by establishing a bus service.

1. True
2. False

- 2-9. The liberty bus service is managed by which of the following personnel?
1. The operation officer
 2. The transportation supervisor
 3. The yard boss
 4. The bus drivers
- 2-10. When should you request the on-site deployed unit's liberty bus policy and schedule?
1. During the BEEP
 2. After the BEEP
 3. During the pre-deployment visit
 4. During the mid-deployment visit
- 2-11. The final approval signature for the liberty bus policy is that of what person?
1. The Alfa company commander
 2. The commanding officer
 3. The operations officer
 4. The executive officer
- 2-12. What location is the hub of communication for trouble calls concerning CESE in the field?
1. The quarterdeck
 2. The barracks
 3. The dispatch office
 4. The mechanic shop
- 2-13. The log to track the flow of field repairs should be maintained by which of the following personnel?
1. The yard boss
 2. The dispatcher
 3. The transportation supervisor
 4. The operations chief
- 2-14. What person should control the operations of the maintenance field crew?
1. The dispatcher
 2. The light shop supervisor
 3. The 5000 shop supervisor
 4. The heavy shop supervisor
-
- Learning Objective: Recognize the duties involved in the equipment maintenance program.
-
- 2-15. The goal of the equipment maintenance program is to keep all CESE in a safe and serviceable condition at a reasonable cost and to detect major deficiencies before they develop into costly repairs.
1. True
 2. False
- 2-16. What person is responsible for the equipment maintenance program for all assigned CESE?
1. The Alfa company operations chief
 2. The Bravo company maintenance chief
 3. The Alfa company maintenance chief
 4. The command master chief
- 2-17. The maintenance supervisor coordinates all equipment requirements, equipment abuse, and reoccurring equipment breakdowns with what person?
1. The yard boss
 2. The Alfa company operations chief
 3. The dispatcher
 4. The fuel truck operator
- 2-18. What person exercises independent judgement as to whether a piece of equipment requires immediate mechanic attention or can be delayed until the next scheduled PM?
1. The maintenance supervisor
 2. The yard boss
 3. The equipment inspector
 4. The pm/cost control clerk

- 2-19. What block on the ERO does the dispatcher sign for customer approval of repaired CESE?
1. Block 76
 2. Block 77
 3. Block 78
 4. Block 79
- 2-20. What person divides all CESE into preventive maintenance groups, prepares the PM schedule, and maintains the PM Record Card?
1. The equipment inspector
 2. The PM/Cost control clerk
 3. The direct turnover clerk
 4. The company clerk
- 2-21. What person communicates with the PM/cost control clerk when updating the equipment status board?
1. The attachment custodian
 2. The yard boss
 3. The dispatcher
 4. The company clerk
- 2-22. Pertinent descriptive data and the maintenance history for a vehicle is contained in what file?
1. The history jacket
 2. The cost control file
 3. The accident file
 4. The maintenance folder
- 2-23. Which of the following records is NOT contained in a history jacket?
1. DOD property record
 2. Equipment attachment registration record
 3. Motor vehicle utilization record
 4. PM record cards
- 2-24. What person is the liaison between the supply office and the mechanic shop?
1. The pm/cost control clerk
 2. The company clerk
 3. The parts expediter
 4. The direct turnover clerk
- 2-25. DTO parts are stored in what sequence?
1. By USN number in PM groups
 2. By manufacturer in PM groups
 3. By part number in PM groups
 4. By EC number in PM groups
- 2-26. When repair parts are received the DTO clerk notifies what person?
1. The company clerk
 2. The dispatcher
 3. The cost control clerk
 4. The postal clerk
- 2-27. What person is responsible for enforcing check-out procedures for manuals, researching part numbers, and preparing NAVSUP Form 1250s?
1. The battalion librarian
 2. The technical librarian
 3. The floor mechanic
 4. The shop supervisor
-
- Learning Objective: Recognize the maintenance levels used in the equipment maintenance program.
-
- 2-28. What level of maintenance is divided into operator maintenance and preventive maintenance?
1. Organizational
 2. Intermediate
 3. Depot
 4. First echelon
- 2-29. Maximizing overall equipment availability and minimize repair cost is the prime objective for what type of maintenance?
1. Intermediate
 2. Depot
 3. Operator
 4. Preventive

- 2-30. What person should participate in minor services and adjustments performed on CESE unless specifically directed otherwise?
1. The operator
 2. The dispatcher
 3. The yard boss
 4. The technical librarian
- 2-31. At what maintenance level is the rebuild and overhaul of individual assemblies accomplished?
1. Organizational
 2. Preventive
 3. Intermediate
 4. Depot
- 2-32. What level of maintenance requires prior approval before extensive repairs are performed or numerous assemblies are rebuilt?
1. Depot
 2. Intermediate
 3. Preventive
 4. Organizational
- 2-33. Depot maintenance is performed by which of the following departments?
1. Civil Engineer Department (CED)
 2. CESE Equipo Department (CED)
 3. Construction Equipment Department (CED)
 4. Contract Equipment Department (CED)
- 2-34. The standard time interval between PM service inspections, for NCF equipment, is what number of working days?
1. 30
 2. 40
 3. 80
 4. 90
- 2-35. What supervisor is responsible for determining when the PM interval for a piece of CESE should be reduced?
1. The heavy shop supervisor
 2. The light shop supervisor
 3. The 5000 shop supervisor
 4. The maintenance supervisor
- 2-36. What type of PM inspection is performed at intervals of 40 working days?
1. Type A
 2. Type B
 3. Type C
 4. Type D
- 2-37. What type of PM inspection is performed when the mileage and hours on a piece of CESE equal that recommended by the manufacturer?
1. Type A
 2. Type B
 3. Type C
 4. Type D
- 2-38. What type of PM inspection is directed by COMSECOND/COMTHIRDNCB representatives?
1. Type A
 2. Type B
 3. Type C
 4. Type D
-
- Learning Objective: Recognize the repair parts program and associated forms used in the equipment maintenance program.
-
- 2-39. Where is the repair parts allowance list for NCF organic and augment CESE located?
1. In the COSAL
 2. In the TOA
 3. In the SKO
 4. In the TAB A

- 2-40. What command funds the repair parts used in the NCF?
1. COMSECOND/COMTHIRDNCB
 2. COMNAVSUP
 3. COMNAVAIR
 4. NAVFACENGCOM
- 2-41. Repairs part are designed to provide 90 percent effectiveness for a total of how many days?
1. 90
 2. 60
 3. 45
 4. 30
- 2-42. The modifier code 98 is used for classifying what type of repair parts?
1. Parts small
 2. Parts large
 3. Parts peculiar
 4. Parts common
- 2-43. What type of parts are classified as general repair items?
1. Parts general
 2. Parts universal
 3. Parts repair
 4. Parts common
- 2-44. Operator's manuals are listed in what parts listing?
1. Modifier 96
 2. Modifier 97
 3. Modifier 98
 4. Modifier 99
- 2-45. What repair parts allowance is designed not to jeopardize the repair parts allowance of the mainbody?
1. Modifier 96
 2. Modifier 97
 3. Modifier 98
 4. Modifier 99
- 2-46. Which of the following items is NOT recorded on the NAVFAC 11200/41?
1. The cost of repair
 2. The hours required for repairs
 3. The shop to perform the repairs
 4. The amount of time the equipment is out of service
- 2-47. Data from the ERO used to compile cost and utilization figures on each piece of CESE is utilized by what command?
1. Civil Engineer Supply Office
 2. Civil Equipment Support Office
 3. Civil Engineer Support Office
 4. Civil Equipment Seabee Office
- 2-48. The ERO Worksheet, NAVFAC 11200/41B, is used to record what information?
1. Extra repairs
 2. All the repair parts
 3. All labor
 4. The purpose of repair manuals
- 2-49. An ERO is required when labor expended making repairs to a vehicle exceed what minimum number of hours?
1. 1
 2. 2
 3. 3
 4. 4
-
- Learning Objective: Identify the responsibilities when supervising the Live Storage, Petroleum Products, and Equipment Acquisition and Disposition Programs.
-
- 2-50. What supervisor controls the Live Storage Program?
1. Transportation
 2. Operations
 3. Storage
 4. Maintenance

- 2-51. CESE should be placed in live storage when there is no planned operational requirements for what time period?
1. 90 working days
 2. 80 working days
 3. 70 working days
 4. 60 working days
- 2-52. CESE eligible for live storage must have what level equipment evaluation code?
1. A2
 2. A3
 3. A4
 4. A5
- 2-53. In a battalion, which department stores, inventories, and issues bulk petroleum products?
1. Mechanic
 2. Operations
 3. supply
 4. Equipment operations
- 2-54. What supervisor is responsible for the storage of petroleum products used in the transportation pool?
1. The light shop
 2. The heavy shop
 3. The transportation
 4. The yard crew
- 2-55. Equipment acquisition and disposition procedures for public works units are outlined in what publication?
1. NAVFAC P-405
 2. NAVFAC P-300
 3. NAVFAC P-306
 4. NAVFAC P-307
- 2-56. What office notifies the NMCB of equipment acquisitions or disposition instructions?
1. Civil Engineer Support Office
 2. Civil Equipment Support Office
 3. COMSECONDD/COMTHIRDNCB Equipo Office
 4. COMSECONDD/COMTHIRDNCB Engineer Office
-
- Learning Objective: Identify the responsibilities when supervising the BEEP.
-
- 2-57. What does the acronym BEEP mean?
1. Battalion Engineer Equipment Program
 2. Battalion Engineer Equipment Platoon
 3. Battalion Evaluation Equipment Platoon
 4. Battalion Equipment Evaluation Program
- 2-58. One purpose of the BEEP is to provide a realistic in-depth condition evaluation of the CESE allowance.
1. True
 2. False
- 2-59. What supervisor provides the transportation supervisor the scheduled CESE list for the BEEP?
1. The heavy shop supervisor
 2. The light shop supervisor
 3. The maintenance supervisor
 4. The 5000 shop supervisor
- 2-60. COMSECONDD/COMTHIRDNCBINST 11200.1 Series recommends that the CESE scheduling be accomplished to complete the BEEP within a maximum of how many working days?
1. 5
 2. 10
 3. 12
 4. 15
- 2-61. The equipment pool must have enough CESE prepared before the commencement of the BEEP to ensure use of all mechanics for a maximum of how many work days?
1. 1
 2. 2
 3. 3
 4. 4

- 2-62. The BEEP assignment list is generated by what person?
1. Battalion operations chief
 2. Battalion operations officer
 3. Alfa company commander
 4. Alfa company operations chief
- 2-63. Which of the following representatives conduct the counterparts meeting before the commencement of the BEEP?
1. NAVFACENGCOM
 2. COMSECONDC/CCMTHIRDNCB
 3. CESO
 4. NAVSUPCOM
- 2-64. The tracking of the status and location of all CESE and Equipment Evaluation Inspection Guides is the responsibility of what person?
1. The yard boss
 2. The collateral equipage custodian
 3. The transportation supervisor
 4. The EO inspectors
- 2-65. During the BEEP, what action enhances the control of equipment and paper work?
1. Enforcing communication
 2. Longer work hours
 3. Securing of liberty
 4. Enforcing Navy Regulations
- 2-66. After the EO inspectors have completed the procedures outlined on the Equipment Inspection Guide, the CESE is taken to what location?
1. Mechanic shop
 2. Collateral equipage
 3. CESE ready line
 4. CESE testing area
- 2-67. What person issues equipment codes for CESE inspected by the EOs?
1. The Alfa operations chief
 2. The EO inspectors
 3. The transportation chief
 4. The yard boss
- 2-68. The EO inspections must be completed no later than how many days before the planned BEEP completion date?
1. 1
 2. 2
 3. 4
 4. 5
- 2-69. What supervisor determines what repair can be performed on CESE based on the work force?
1. The transportation supervisor
 2. The shop supervisor
 3. The maintenance supervisor
 4. The operations supervisor
- 2-70. The maintenance supervisors review all the Equipment Evaluation Inspection Guides and approve what codes for each CESE?
1. Equipment Codes (EC)
 2. Equipment Condition Codes
 3. Equipment Acceptance Codes
 4. Equipment Cost Codes
- 2-71. Representatives from what command approves all BEEP Equipment Evaluation Inspection Guides?
1. NAVFACENGCOM
 2. CESO
 3. NAVSUPCOM
 4. COMSECONDC/COMTHIRDNCB
-
- Learning Objective: Identify the responsibilities of the License Examiner.
-
- 2-72. A properly administered license program ensures only thoroughly trained personnel are licensed.
1. True
 2. False

2-73. The license examiner must be appointed by letter by what person?

1. The company commander
2. The operations officer
3. A COMSECON/COMTHIRDNCB representative
4. The commanding officer

2-74. Which of the following is NOT a required publication for the library that the license examiner must maintain?

1. OPNAVINST 11240.16A
2. NAVFAC P-306
3. NAVFAC P-404
4. NAVFAC P-405

2-75. The maintenance procedures for the files on licensed operators must comply with the provisions of what legal document?

1. The Privacy Act of 1974
2. The Privacy Act of 1972
3. The Privacy Act of 1977
4. The Privacy Act of 1992

ASSIGNMENT 3

Textbook Assignment: "Transportation Supervisor," and "Air Detachment Equipment Supervisor" pages 1-38 through 2-16.

Learning Objective: (continued)
Identify the responsibilities of
a license examiner.

- 3-1. What form is used to apply for a material-handling equipment license?
1. NAVFAC 11240/10
 2. NAVFAC 11240/2
 3. NAVFAC 11240/13
 4. NAVFAC 11240/9
- 3-2. License application forms are completed by the applicants and must be signed by what person?
1. Commanding officer
 2. Project supervisor
 3. Company chief
 4. Transportation supervisor
- 3-3. What publication states military personnel may operate government-owned vehicles under 10,000 pounds GVW without a government license?
1. NAVFAC P-306
 2. NAVFAC P-300
 3. NAVFAC P-307
 4. NAVFAC P-404
- 3-4. The SF-47 is retained in an applicant's license file and is replaced with a new one at what time?
1. Once a year
 2. When the license is renewed
 3. When the license is lost
 4. Every two years
- 3-5. A license examiner should have a minimum of how many written examinations for each type of equipment?
1. One
 2. Two
 3. Three
 4. Four
- 3-6. Sample written tests for construction and weight-handling equipment are contained in what publication?
1. NAVFAC P-300
 2. NAVFAC P-405
 3. NAVFAC P-306
 4. NAVFAC P-307
- 3-7. The license examiner does NOT give a performance qualification test for what type of equipment?
1. Dozers
 2. Rock drills
 3. Graders
 4. Cranes
- 3-8. What manual contains sample MHE test questions?
1. NAVFAC P-307
 2. NAVFAC P-300
 3. DODINST 4145.19-R-1
 4. DODINST 4160.21M
- 3-9. Which of the following states does NOT require a valid state driver's license in addition to the OF-346 to operate government-owned vehicles off base?
1. Florida
 2. Nebraska
 3. Alaska
 4. Vermont

- 3-10. Which, if any, of the following information can be derived from an OF-346 with the number 133-001?
1. It belongs to the CO of NMCB-133
 2. It is the first license issued by NMCB-133
 3. It is the one hundred thirty-third license issued by NMCB-1
 4. None of the above
- 3-11. The license examiner issues an OF-346 on 10 Jan 93 to an individual with a birth date of 12 Jun 70. Unless renewed, the license expires on what date?
1. 10 Jan 96
 2. 10 Jan 95
 3. 12 Jun 96
 4. 12 Jun 95
- 3-12. Typical notations, such as JD670, D7 Cat, are found in what block on the NAVFAC 11260/2?
1. Equipment type
 2. Size and capacity
 3. Attachment
 4. Type of control
- 3-13. License renewal actions should start a maximum of how many days before the expiration date?
1. 90
 2. 60
 3. 45
 4. 30
- 3-14. Under what condition is a government operator license automatically extended?
1. While assigned to NCTC for training
 2. While traveling under PCS orders
 3. While deployed with an air detachment
 4. While assigned to a combat zone
- 3-15. By power of authority, an operator's license can be revoked by which of the following people?
1. Equipment officer
 2. Maintenance supervisor
 3. Transportation chief
 4. License examiner
- 3-16. In a battalion, what officer conducts traffic court?
1. The legal officer
 2. The commanding officer
 3. The equipment officer
 4. The executive officer
- 3-17. When an operator's license is revoked, the license examiner makes a notation of the date revoked on what form?
1. NAVFAC 11260/4
 2. NAVFAC 11260/3
 3. NAVFAC 11260/2
 4. NAVFAC 11260/1
- 3-18. The personnel office is responsible for including the license examiner in the check-in or check-out process of personnel in a command.
1. True
 2. False
- 3-19. Poor equipment operating practices cause accidents and equipment breakdowns. To reduce these problems, a license examiner can establish what type of program?
1. Security
 2. Maintenance
 3. Safety
 4. Training
- 3-20. A training license expiration date should not exceed a maximum of how many days from the date of issue?
1. 15
 2. 20
 3. 25
 4. 30

3-21. Mishap investigation guidelines are presented in which of the following manuals?

1. OPNAVINST 11240.16 series
2. OPNAV P09B2-105
3. OPNAVINST 5102.1
4. COMSECOND/COMTHIRDNCBINST 4400.3

3-22. A NAVGRAM is required for a mishap that results in damage that totals how many dollars?

1. \$2500
2. \$2000
3. \$1500
4. \$1000

3-23. In an NMCB, what person should check the route before moving an oversize load on a public highway?

1. The driver
2. The yard boss
3. The roadmaster
4. The dispatcher

Learning Objective: Recognize the responsibilities of the air detachment equipment supervisor.

3-24. After notification, the air detachment should be capable of deploying within a maximum of how many hours?

1. 12
2. 24
3. 48
4. 72

3-25. The air detachment must be self-sufficient for a maximum of how many days?

1. 10
2. 15
3. 25
4. 30

3-26. What person is responsible for the daily management of assigned CESE to the air detachment?

1. Officer in charge (OIC)
2. Assistance officer in charge (AOIC)
3. Senior Alfa company rating
4. Air det operations chief

3-27. When assigning personnel to the air det, the battalion operations department uses the guidelines presented in what manual?

1. NCF embarkation manual
2. NCF mobilization planning manual
3. MAC pamphlet airlift planners manual
4. NCF troop movement manual

3-28. The PM/cost control clerk is assigned to which air detachment platoon?

1. Support
2. Equipment
3. Construction
4. Maintenance

3-29. Equipment platoon administration readiness is the process of storing office supplies and forms to provide a minimum of how many days support?

1. 15
2. 20
3. 25
4. 30

3-30. Which of the following forms is NOT required to be stored for support of equipment platoon readiness?

1. NAVFAC 9-11260/4
2. NAVFAC 9-11240/13
3. NAVFAC 6-11200/45
4. NAVFAC 11200/41

Learning Objective: Recognize the Table of Allowance (TOA) used in the NCF.

Learning Objective: Recognize the responsibilities when identifying and preparing CESE for the air detachment.

- 3-31. The TOA outfits the NMCB with tools and equipment to perform construction operations under contingency conditions for a minimum of how many days?
1. 90
 2. 45
 3. 30
 4. 15
- 3-32. What command is responsible for maintaining the NCF TOAs?
1. CESO
 2. CESOC
 3. CED
 4. COMSECOND/COMTHIRDNCB
- 3-33. The NCF TOA Is divided into three echelons. What echelon is designated for the air det?
1. TA21
 2. TA31
 3. TA41
 4. TA51
- 3-34. What is the kit number designator for lubrication equipment and accessories?
1. 80013
 2. 80031
 3. 80057
 4. 80107
- 3-35. When requesting Mod 96, Mod 98, and POL products, the lead mechanic coordinates the request with what person?
1. The heavy shop supervisor
 2. The light shop supervisor
 3. The maintenance supervisor
 4. The 5000 shop supervisor
- 3-36. During the 48 hour mount-out, the requested kits and supplies are staged at what location?
1. Alfa company yard
 2. Battalion grinder
 3. Battalion spaces
 4. Marshaling area
- 3-37. The air det CESE allowance for a deployment site is contained in what listing?
1. TAB A
 2. TA41
 3. TAB B
 4. TA31
- 3-38. The prioritizing of CESE, supplies, and POL products allows what office to prepare load plans?
1. Equipment
 2. supply
 3. Embarkation
 4. Dispatch
- 3-39. The CESE and cargo that are placed into a configuration for each aircraft is known by what term?
1. Cargo load
 2. Chalk
 3. Plane load
 4. Staged load
- 3-40. Special handling data is documented on what form?
1. DD Form 1387-2
 2. DD Form 1348-1
 3. DD Form 1342
 4. DD Form 2133
- 3-41. Who directs the operations of the MOCC?
1. Equipment officer
 2. Supply officer
 3. Executive officer
 4. Embarkation officer

3-42. During a mount-out, what area serves as a coordinating center for all companies and staff personnel?

1. Alfa company
2. Quarterdeck
3. Marshaling yard
4. MOCC

3-43. Embarking CESE on aircraft requires following the special loading procedures that are outlined in what manual?

1. 3120.1 series
2. 11200.1 series
3. P-404
4. P-300

3-44. During the mount-out, what members are responsible for knowing the location of the bolts, nuts, and parts for disassembled equipment?

1. Mechanic shop
2. Equipment platoon
3. Support platoon
4. Transportation yard crew

3-45. After Alfa company is completed with a piece of CESE, what location does the dispatcher notify that the CESE is ready to be transferred?

1. Quarterdeck
2. Operations
3. MOCC
4. Air operations

Learning Objective: Recognize the weighing and marking procedures, and' shoring used in the NCF.

3-46. When computing the center of balance (C/B) of a piece of CESE, you should perform what step first?

1. Establish the distance to the front axle
2. Establish the distance to the trunnion
3. Compute the weight of the front axle
4. Establish the reference datum line

3-47. In the weighing and marking process, at what step is the vehicle placed on portable scales?

1. When computing for D1
2. When computing for FAW, IAW,RAW
3. When computing for D2
4. When computing for D3

3-48. The RAW for a vehicle with tandem axles is the total weight of what two weights added together?

1. FAW + IAW
2. FAW + RAW
3. IAW + RAW
4. GVW + RAW

3-49. To locate the C/B of a vehicle, you measure from what location?

1. From D1
2. From D2
3. From D3
4. From RDL

3-50. What letters are written on the horizontal portion of the tape used to denote the C/B of a vehicle?

1. GVW
2. RDL
3. FAW
4. RAW

3-51. What type of shoring is required for track equipment?

1. Parking
2. Sleeper
3. Approach
4. Roller

3-52. What type of shoring is used for rollers?

1. Parking
2. Approach
3. Sleeper
4. Roller

3-53. What type of shoring is required for long vehicles such as low-boy trailers?

1. Parking
2. Approach
3. Sleeper
4. Roller

3-54. What shoring is used to prevent vehicles with soft tires from bouncing inside the aircraft?

1. Parking
2. Approach
3. Sleeper
4. Roller

Learning Objective: Recognize the procedures used when palletizing cargo in the NCF.

3-55. The surface structure of the 463L is made of a corrosion resistant aluminum. The core is made of what type of material?

1. Plywood
2. Hardwood
3. Dogwood
4. Softwood

3-56. To prolong the life of a 463L pallet, you should ensure load weight placed on the pallet not exceed what maximum weight?

1. 8,000 pounds
2. 7,500 pounds
3. 7,000 pounds
4. 6,500 pounds

3-57. The top net of the pallet nets is identified by what color?

1. Blue
2. Green
3. Yellow
4. Brown

3-58. Aisleways must be built on pallets that are to be loaded on a C-130 aircraft in what positions?

1. One or two
2. Three or four
3. Five or six
4. Seven or eight

3-59. Technical publications require forklift tines be what minimum length?

1. 36 inches
2. 48 inches
3. 60 inches
4. 72 inches

3-60. What piece of equipment in the NCF TOA has a set of roller tine fork extensions assigned as an attachment?

1. R/T forklift
2. 4K forklift
3. 6K forklift
4. 12K Lift King forklift

Learning Objective: Recognize the collateral equipage, site selection, and site arrival activities of the air detachment.

3-61. Proper management of the air det collateral equipage program enhances your equipment management program for the air det.

1. True
2. False

3-62. What environmental factor must not be overlooked when considering a site for the equipment pool?

1. Drainage
2. Type of soil
3. Amount of vegetation
4. Amount of trees

3-63. When the air det embarks by airlift, what number designates how members are scheduled to depart?

1. The ticket number
2. The aircraft number
3. The chalk number
4. The seat number

3-64. What group normally remains at the airfield until all scheduled chalks arrive at the mission site?

1. Arrival Air Force Control Group
2. Airlift Arrival Control Group
3. Arrival Airlift Combat Group
4. Arrival Airlift Control Group

3-65. What platoon has the responsibilities of transporting both cargo and personnel from the airfield to the mission site?

1. Equipment
2. Support
3. Transport
4. Construction

3-66. What platoon has the key responsibility for camp setup?

1. Equipment
2. Support
3. Construction
4. Operations

Learning Objective: Recognize the responsibilities of the equipment platoon operations.

3-67. For control and accountability, what is the best dispatch assignment for air det assigned CESE?

1. Class A
2. Class B
3. Class C
4. Class D

3-68. What person is responsible for equipment-related operations of the air det?

1. The support platoon supervisor
2. The construction platoon supervisor
3. The equipment platoon supervisor
4. The assistant officer in charge

3-69. During the first few days of an air det operations, what is one of the most important pieces of CESE?

1. The roller
2. The grader
3. The generator
4. The forklift

3-70. What platoon has the responsibility to check and fill water buffalos and make daily dump runs?

1. Support
2. Construction
3. Equipment
4. Engineer

3-71. Fuel drums and POL products must be stored what minimum number of feet away from any structure?

1. 50
2. 45
3. 30
4. 25

3-72. What supervisor should direct the operations of the maintenance field crew?

1. Support platoon supervisor
2. Air det maintenance supervisor
3. Construction platoon supervisor
4. Air det engineer supervisor

3-73. When performing maintenance on air det CESE, you are required to document which of the following items?

1. Repair parts used
2. Lube oils used
3. Man-hours expended
4. All of the above

3-74. Guidelines for the air det maintenance program are outlined in what instruction?

1. COMSECOND/COMTHIRDNCBINST 11200.1 series
2. COMSECOND/COMTHIRDNCBINST 1500.22 series
3. COMSECOND/COMTHIRDNCBINST 4400.3 series
4. COMSECOND/COMTHIRDNCBINST 11200.11 series

3-75. The success of the air det mission is primary and should always be attained even at the cost of destroying CESE.

1. True
2. False

ASSIGNMENT 4

Textbook Assignment: "Air Detachment Equipment Supervisor," "Crane Crew Supervisor," and "Projects Supervisor," pages 2-16 through 4-11.

Learning Objective: Recognize the air det responsibilities for projects, mount-out, and retrograde operations.

- 4-1. What is the primary function of the construction platoon?
1. To perform equipment operations
 2. To perform camp operations
 3. To perform construction operations
 4. To perform communication operations
- 4-2. The tailoring of ratings assigned to the air det is dependent upon the extent and variety of tasking.
1. True
 2. False
- 4-3. What person is responsible for developing a productive method for washing CESE for the mount-out?
1. Support platoon supervisor
 2. Air det operations chief
 3. Equipment platoon supervisor
 4. Air det embarkation officer
- 4-4. CESE preparation is a time-consuming event that must be properly planned in order to meet the deadline for the joint inspection.
1. True
 2. False
- 4-5. What governmental agency may require a de-bugging steam wash be conducted on all CESE?
1. The Department of Environmental protection
 2. The Department of Motor Vehicles
 3. The Department of Health and Welfare
 4. The Department of Agriculture
- 4-6. What does the acronym DACG mean?
1. Dependent Airlift Crew Group
 2. Deployment Airlift Construction Group
 3. Departure Airlift Construction Group
 4. Departure Airlift Control Group
- 4-7. What term identifies the period of time in which items are inventoried reordered, cleaned, and turned in?
1. BEEP
 2. Mount in
 3. Retrograde
 4. Return grade
- 4-8. The final condition of CESE and the positive accountability of collateral equipage and of tool kits determines your final grade in the successful management of air det CESE?
1. True
 2. False

Learning Objective: Recognize the responsibilities for the selection and training of crane crews in the NCF.

- 4-9. At least what percentage of crane accidents results from operator inattention, poor judgment, overconfidence, and/or excessive speed?
1. 70%
 2. 75%
 3. 80%
 4. 85%
- 4-10. Which of the following publications does NOT contain outline standards for weight-handling equipment?
1. NAVFAC P-307
 2. NAVFAC P-404
 3. NAVFAC P-405
 4. NAVFAC P-306
- 4-11. Which of the following supervisors must be designated in writing by the commanding officer?
1. Transportation
 2. Crane crew
 3. Projects
 4. Quarry
- 4-12. In an NMCB, at what time should the crane crew be selected?
1. At the beginning of the deployment
 2. At the beginning of the home-port period
 3. At the end of the home-port period
 4. During the BEEP
- 4-13. Crane operators assigned to the crane crew should have what characteristics?
1. Maturity and experience
 2. Experience and personality
 3. Maturity and education
 4. Education and personality
- 4-14. Crane operators must meet the minimum physical examination requirements as established by what NAVFAC publication?
1. P-415
 2. P-404
 3. P-306
 4. P-315
- 4-15. Before receiving a license to operate a crane, an operator must attend a minimum of how many hours of formal classroom training?
1. 8
 2. 24
 3. 32
 4. 40
- 4-16. What person in an NMCB has the direct responsibility for testing crane operators?
1. Crane test director
 2. Crane crew leader
 3. Certified crane supervisor
 4. Crane certifying officer
- 4-17. What person in an NMCB designates in writing the crane test mechanic?
1. Commanding officer
 2. Operations officer
 3. Crane certifying officer
 4. Crane test director
-
- Learning Objective: Recognize the procedures for performing the BEEP of cranes.
-
- 4-18. The weight testing of cranes is a time-consuming event and should be completed before the end of the BEEP.
1. True
 2. False

- 4-19. Which of the following personnel have the responsibility of performing the "before" "during," and "after" inspection of the crane?
1. Crane certifying officer
 2. Crane test operator
 3. Crane test mechanic
 4. Crane test rigger
- 4-20. When transporting a crane on the open road, you must avoid any power source by at least what distance?
1. 4 feet
 2. 10 feet
 3. 15 feet
 4. 20 feet
- 4-21. Which of the following personnel have the responsibility for completing the crane lift checklist?
1. Crane certifying officer
 2. Crane crew supervisor
 3. Crane crew rigger
 4. Crane crew operator
- 4-22. What is the minimum requirements for retaining ODCLs?
1. ODCLs from the past 90 days of operations and ODCLs of the current month
 2. ODCLs from the past 60 days of operations and ODCLs of the current month
 3. ODCLs from the previous month of operations and ODCLs of the current month
 4. ODCLs of the current month of operation
- 4-23. More than two broken wires in one lay in sections beyond the end connection is the condition for replacing what section of wire rope?
1. Wire rope connected to a wedge socket
 2. Boom pendant ropes
 3. Boom hoist ropes
 4. Wire rope connected to a winch
- 4-24. The use of a wedge socket develops only what percentage of the breaking strength of the wire rope?
1. 90%
 2. 80%
 3. 70%
 4. 60%
- 4-25. When should the crane hook block be magna-fluxed?
1. After 5 years of service
 2. After the crane has been released from deadline
 3. After any repairs performed on the hook block
 4. Every fifth certification
-
- Learning Objective: Recognize the test procedures performed when weight-testing cranes.
-
- 4-26. A mobile crane is weight-tested at what percentage of the rated capacity of the crane?
1. 100%
 2. 110%
 3. 115%
 4. 125%
- 4-27. When lifting a load that exceeds 75 percent of a crane's rated capacity, you should determine the operating radius in what manner?
1. By reading the boom angle indicator
 2. By actually measuring the operating radius
 3. By watching the boom pendant angle
 4. By reading the load chart
- 4-28. You are assigned to weight test a mobile crane. What is the test weight for a mobile crane with a rated capacity of 72,300 pounds?
1. 65,727 pounds
 2. 79,530 pounds
 3. 82,159 pounds
 4. 90,375 pounds

- 4-29. What is the safe working load of a 3/4-inch hoist wire rope?
1. 4.5 tons
 2. 6.0 tons
 3. 9.7 tons
 4. 10.4 tons
- 4-30. What is the breaking strength of a 3/4-inch hoist wire rope?
1. 22.5 tons
 2. 30.0 tons
 3. 48.5 tons
 4. 52.0 tons
- 4-31. What is the breaking strength of a 3/4-inch wire rope rigged with a wedge socket?
1. 36.4 tons
 2. 34.0 tons
 3. 21.0 tons
 4. 15.8 tons
- 4-32. What is the safety factor of a 3/4-inch wire rope used as rope that winds on drums or passes on sheaves?
1. 4.50 tons
 2. 6.00 tons
 3. 9.70 tons
 4. 10.4 tons
- 4-33. What is the test weight for a 3/4-inch wire rope rigged on a mobile crane?
1. 9,900 pounds
 2. 13,200 pounds
 3. 21,340 pounds
 4. 22,880 pounds
- 4-34. What percentage of crane capacity is lost when the crane has a short boom at maximum radius and is 3 degrees out of level?
1. 30%
 2. 20%
 3. 15%
 4. 10%
- 4-35. When conducting a maximum load test, you hold the load clear of the ground without the boom and load hoist pawls engaged for what time period?
1. 5 minutes
 2. 10 minutes
 3. 15 minutes
 4. 20 minutes
- 4-36. When conducting a dynamic test of the auxiliary hoist, you must wait what length of time after raising and lowering the test load before continuing the test?
1. 20 minutes
 2. 15 minutes
 3. 10 minutes
 4. 5 minutes
- 4-37. Cranes rigged for clamshell, dragline, or pile-driving operations should be weight-tested according to what factor?
1. The maximum capacity of the crane
 2. The minimum capacity of the crane
 3. The safe working load for the size of wire rope used
 4. The safe working load on the load charts
- 4-38. Retesting of the crane is required when changing from clamshell to dragline.
1. True
 2. False
- 4-39. At which of the following locations is the certification of load test and condition inspection filed?
1. Equipment history jacket
 2. Unit safety office
 3. Protective container on the crane
 4. All of the above

- 4-40. What is the most critical portion of the operation of a crane?
1. Moving the crane
 2. Setting up for a lift
 3. Rotating the crane
 4. Rigging for a lift
- 4-41. The rated capacities of mobile cranes are based on what factors?
1. Strength and sensibility
 2. Strength and mobility
 3. Strength and desirability
 4. Strength and stability
- 4-42. In an NMCB, which of the following personnel is NOT required to attend the biweekly crane operation and safety meetings?
1. Alfa company commander
 2. Crane test director
 3. Battalion safety chief
 4. Crane supervisor and operator
-
- Learning Objective: Recognize the NCF wire rope sling and rigging hardware program.
-
- 4-43. What person is responsible for the turnover of all slings and rigging hardware during the BEEP?
1. Crane test operator
 2. Crane certifying officer
 3. Crane crew rigger
 4. Crane crew supervisor
- 4-44. The factor of safety for wire rope slings is what ratio?
1. 5.0 to 1
 2. 3.5 to 1
 3. 3.0 to 1
 4. 4.0 to 1
- 4-45. The total weight of a load carried by a single-leg sling at 90 degrees is what type of sling?
1. Bridle hitch
 2. Choker hitch
 3. Double-vertical hitch
 4. Single-vertical hitch
- 4-46. The sling angle for a two-leg sling is at 30 degrees hoisting a 1,000-pound object. What total stress weight is each leg hoisting?
1. 500 pounds
 2. 750 pounds
 3. 1,000 pounds
 4. 1,500 pounds
- 4-47. If a thimble is not used in an eye of a wire rope, what percentage of efficiency of the connection is lost?
1. 5%
 2. 10%
 3. 15%
 4. 20%
- 4-48. When properly fabricated, which of the following eye splices develops almost 100 percent of the catalogue breaking strength of the wire rope?
1. Flemish eye and serving
 2. Flemish eye and pressed metal sleeve
 3. Tucked eye and serving
 4. Fold back eye and pressed metal sleeve
- 4-49. It is highly recommended that what eye splice never be used for overhead hoisting operations?
1. Flemish eye and serving
 2. Tucked eye and serving
 3. Fold back eye and pressed metal sleeve
 4. Tucked eye and pressed metal sleeve
- 4-50. What person is responsible for establishing and maintaining a card file system containing records of each sling in the unit's inventory?
1. Crane test director
 2. Crane crew rigger
 3. Crane crew mechanic
 4. Crane crew supervisor

4-51. A sling should be maintained on the crane at the end of each workday.

1. True
2. False

4-52. Which of the following number of designators does NOT identify an NCF TOA slings and rigging gear kit?

1. 80104
2. 84003
3. 84004
4. 80056

4-53. To avoid confusion and doubt, you may downgrade a sling to a lower capacity.

1. True
2. False

4-54. What kit in the NCF TOA contains the tools and equipment necessary to fabricate 3/8-inch through 5/8-inch sizes of wire rope slings?

1. 80104
2. 80107
3. 80092
4. 84004

4-55. At what periodic intervals should a visual inspection of all wire rope slings and rigging gear be performed?

1. Every 30 days
2. Every 60 days
3. Every 75 days
4. Every 90 days

4-56. The recommended COMSECOND/COMTHIRDNCBINST wire rope lubricant is composed of what mixture?

1. 70% diesel to 30% used oil
2. 70% diesel to 30% new oil
3. 70% new oil to 30% gas
4. 70% new oil to 30% diesel

4-57. What action is required when rigging gear becomes defective?

1. Downgrade the capacity
2. Survey it through supply
3. Destroy it by cutting it up
4. Store it in the rigging loft

Learning Objective: Recognize the responsibilities of the project supervisor and the concepts of construction used in an NMCB.

4-58. In an NMCB, what person has direct responsibility for the successful completion of all construction projects?

1. Commanding officer
2. Operations officer
3. Operations chief
4. Project supervisor

4-59. In an NMCB, what officer has the direct supervisory authority over the utilization of the battalion's construction resources?

1. Executive officer
2. Supply officer
3. Embarkation officer
4. Operations officer

4-60. Within the Alfa company organization, what person is responsible to A-6 for all prime and sub projects?

1. A-5
2. A-4
3. A-3
4. A-32

4-61. In an NMCB, what person appoints project supervisors for assigned construction projects?

1. Company commander
2. Operations officer
3. Operations chief
4. Projects chief

- 4-62. What person determines the organizational concept of construction used in an NMCB?
1. CO and S-3
 2. NAVFACENCOM
 3. COMSECOND/COMTHIRDNCB
 4. Naval Construction Regiment
- 4-63. What is the most common construction concept used in the NCF?
1. Project manager/resource manager
 2. Prime contractor/lead company
 3. Self-sufficient unit/detail
 4. Prime company/lead contractor
- 4-64. What NAVFAC publication outlines the concepts of construction used in the NCF?
1. NAVFAC P-405
 2. NAVFAC P-404
 3. NAVFAC P-320
 4. NAVFAC P-315
- 4-65. At what step of deployment planning does the battalion receive preliminary tasking and begin monitoring the efforts of the on-site battalion?
1. Initial
 2. Detailed
 3. Follow on
 4. Follow-up
- 4-66. At what planning step are personnel assigned to details, companies, and staff billets?
1. Detailed
 2. Follow-up
 3. Initial
 4. Follow-on
- 4-67. What element assists companies and details with the planning effort and coordinates the detail analysis of project requirements?
1. Material liaison office
 2. Quality control element
 3. Material construction control
 4. Quality construction element
- 4-68. What areas are inspected during the first of the three phases of a readiness-to-deploy inspection?
1. Battalion organization and training plans
 2. CESE management plans
 3. Construction project plans
 4. Execution plans
-
- Learning Objective: Recognize the steps performed to compute earthwork volumes.
-
- 4-69. Mistakes made in P&E can be detrimental to the successful completion of a construction project.
1. True
 2. False
- 4-70. What total number of cubic feet equals 1 cubic yard?
1. 3
 2. 9
 3. 27
 4. 36
- 4-71. When calculating estimates from construction prints, you must remember that cuts are measured in what state?
1. Inplace cubic yards
 2. Compacted cubic yards
 3. Loose cubic yards
 4. Swell cubic yards
- 4-72. In road construction, what is the name of the slope that extends from the outside of the shoulder to the bottom of the ditch?
1. Foreslope
 2. Sideslope
 3. Backslope
 4. Frontslope

4-73. When computing the area of a cross section, you perform what step first?

1. Compute the slope ratio
2. Break the section down into geometric figures
3. Compute distance between stations
4. Compute elevation of the final grade

4-75. In a project package, on what document is the equipment requirements to support each construction activity documented?

1. MAS sheet
2. CAS sheet
3. MTO
4. BM

4-74. What NAVPAC publication contains equipment production rates?

1. NAVFAC P-404
2. NAVFAC P-300
3. NAVFAC P-306
4. NAVFAC P-405

ASSIGNMENT 5

Textbook Assignment: "Quarry Supervisor," "Crusher Supervisor," "Concrete Batch Plant Supervisor," and "Asphalt Plant Supervisor," pages 5-1 through 8-10.

Learning Objective: Recognize the classifications of pits and quarries and the types of material obtained from them.

- 5-1. In an NMCB, what company is responsible for the management of pit and quarry operations?
1. Alfa
 2. Bravo
 3. Charlie
 4. Headquarters
- 5-2. Pits and quarries are classified based on which of the following factors?
1. Type of material contained within
 2. Method used to excavate the material contained within
 3. Method used to process the material taken from
 4. Each of the above
- 5-3. Which of the following is NOT a primary material obtained from a quarry?
1. Granite
 2. Slag
 3. Gneiss
 4. Quartzite
- 5-4. The crust of the earth consists of rock deposits geologists have classified into what three groups?
1. Sedimentary, igneous, and shale
 2. Sedimentary, metamorphic, and alluvial
 3. Igneous, metamorphic, and sedimentary
 4. Igneous, silica, and brick
- 5-5. The hardness of a rock is classified according to the resistance the rock has to crushing.
1. True
 2. False
- 5-6. Aggregates used in construction should be rated within what hardness range?
1. Between 1 to 2
 2. Between 2 to 4
 3. Between 5 to 7
 4. Between 8 to 10
- 5-7. What term identifies the range and distribution of particle sizes present in, or can be obtained from, a deposit?
1. Sieve analysis
 2. Material fines
 3. Breakdown analysis
 4. Gradation
- 5-8. What type of quarry material is not suitable for concrete aggregate?
1. Granite
 2. Felsite-Rhyolite
 3. Basalt
 4. Gabbro-Diorite
- 5-9. The portion of a soil sample retained on the No. 200 sieve is considered what type of aggregate?
1. Coarse
 2. Medium
 3. Small
 4. Fine

- 5-10. Which of the following factors affect the compaction of soil?
1. Material gradation
 2. Moisture content
 3. Compaction effort
 4. All of the above
- 5-11. Optimum moisture content is the amount of water in the soil required to obtain maximum density.
1. True
 2. False
-
- Learning Objective: Recognize site preparation procedures and the operational processes of a pit or quarry.
-
- 5-12. What should you check before burning brush on a proposed pit or quarry site?
1. Weather
 2. Type of fire extinguisher
 3. Requirement for a smoke permit
 4. Requirement for a burn permit
- 5-13. Overburden should be kept cleared at least how far back from the top of the face of a quarry?
1. 50 feet
 2. 40 feet
 3. 25 feet
 4. 10 feet
- 5-14. What is the maximum grade for a haul road designed for use by truck operations in a quarry?
1. 5 percent
 2. 10 percent
 3. 15 percent
 4. 20 percent
- 5-15. A chute loading ramp should be constructed to support a minimum of how many tons of material?
1. 5 tons
 2. 10 tons
 3. 15 tons
 4. 20 tons
- 5-16. When a pusher-assisted scraper cannot load within 150 feet, you should use what equipment?
1. An additional scraper
 2. An extra pusher
 3. A ripper tractor
 4. A front-end loader
- 5-17. Which of the following quarries is a type commonly used by the military?
1. Double bench
 2. Open faced
 3. Triple bench
 4. Closed faced
- 5-18. What factor determines the layout of a quarry where the rock formation is jointed?
1. The method of development
 2. The depth of overburden
 3. The direction of rock formation
 4. The lay of the strata
- 5-19. In the NCF, what is the recommended bench height in a quarry?
1. 10 feet
 2. 15 feet
 3. 20 feet
 4. 25 feet
- 5-20. In the NCF, what is the recommended minimum width of a bench?
1. 40 feet
 2. 50 feet
 3. 60 feet
 4. 70 feet

- 5-21. What person is responsible for ensuring operator maintenance is performed on quarry equipment?
1. Operations chief
 2. Maintenance supervisor
 3. Maintenance field crew
 4. Quarry supervisor
- 5-22. What NAVFAC publication provides guidelines for wearfacing equipment parts?
1. P-404
 2. P-433
 3. P-405
 4. P-300
- 5-23. Putting off maintenance to satisfy immediate production demands sets a good precedence and increases the life of the equipment.
1. True
 2. False
- 5-24. What is the NEC of a qualified blaster?
1. 5710
 2. 5709
 3. 5708
 4. 5707
-
- Learning Objective: Recognize the principles and methods of crusher operations.
-
- 5-25. What command directs the tasking of crusher operations for an NMCB?
1. NAVFACENGCOM
 2. NAVCHAPGRU
 3. COMSECOND/COMTHIRDNCB
 4. COMNCFNCB
- 5-26. The classification of a crusher plant is based on what factor?
1. Capacity output
 2. Weight of crusher unit
 3. Size jaws
 4. Area displacement
- 5-27. What is the function of the heavy-duty apron type of feeder?
1. Feeds material to the secondary unit
 2. Sorts material before feeding the secondary unit
 3. Feeds material to the primary unit
 4. Sorts material before feeding the primary unit
- 5-28. What component of the primary unit prescreens material that is already down to the desired size?
1. Vibrating screens
 2. Apron feeder
 3. Under crusher delivery conveyer
 4. Vibrating grizzly
- 5-29. In a rock crusher, what problem occurs when two rocks interlock and bridge the jaws open?
1. Blocking
 2. Bridging
 3. Choking
 4. Packing
- 5-30. What factor determines the production setting for a dual roll crusher?
1. The shell combination
 2. The speed setting
 3. The spacing between the rolls
 4. The hydroset control pressure
- 5-31. The fineness of the product being produced by a hydrocone crusher is adjusted by what action?
1. By raising or lowering the mantle
 2. By adjusting the feed spout
 3. By controlling the hydroset pressure
 4. By adjusting the concave ring

- 5-32. Material from the hydrocone crusher is recirculated to the top screen by what components?
1. The return conveyer and the revolving elevator wheel
 2. The under conveyer and a drop chute
 3. The under conveyer and the revolving elevator wheel
 4. The return conveyer and a crossover chute
- 5-33. The desired performance of a specific screen is obtained by taking which of the following actions?
1. Varying the degree of inclination
 2. Varying the frequency and amplitude of stroke
 3. Varying the direction of throw
 4. All of the above
- 5-34. Which of the following is NOT a factor that affects the operational efficiency of a conveyer?
1. Speed
 2. Length of travel
 3. Loading
 4. Incline
- 5-35. What factor determines the capacity of a washing and screening plant?
1. Water pressure
 2. Speed of the dehydrator
 3. Percent of sand in the deposit
 4. Capacity of the scrubber
-
- Learning Objective: Recognize crusher supervisor responsibilities for developing the layout and erection of a crusher plant.
-
- 5-36. When you are developing a layout of a plant, special attention must be given to creating a logical flow of material.
1. True
 2. False
- 5-37. Which of the following materials can contaminate open stockpiles of aggregate?
1. Windblown sand
 2. Fines
 3. Trash
 4. All of the above
- 5-38. When you are building stockpiles, which of the following pieces of equipment is more efficient because it can combine lift with push to build higher piles?
1. Dozer
 2. Clamshell
 3. Loader
 4. Excavator
- 5-39. Which of the following physical characteristics should the site selected for the erection of a plant have?
1. Flat
 2. Level
 3. Well compacted
 4. All of the above
- 5-40. When torquing bolts and nuts on the plant, you do so by torquing the bolt head.
1. True
 2. False

5-41. Of the following basic setups for a 75-tph crushing plant, which one should be used when the bulk of material from a gravel deposit is 3 inches in diameter or less?

1. Jaw crusher
2. Primary unit only
3. Secondary unit only
4. Primary and secondary units together

5-42. The entire quarry and rock production operation depends on improper and inadequate maintenance of equipment.

1. True
2. False

Learning Objective: Recognize the properties of and uses for various types of cement that a concrete batch plant supervisor works with.

5-43. The chemical reaction between cement and water that produces concrete is known by what term?

1. Concrete
2. Hydraulics
3. Hydration
4. Evaporation

5-44. What type of cement requires less protection from freezing and attains normal 3-day strength in 1 day?

1. I
2. II
3. III
4. IV

5-45. Aggregates used in concrete occupy what percentage of the mix by weight?

1. Between 90% to 95%
2. Between 70% to 85%
3. Between 60% to 75%
4. Between 50% to 55%

5-46. Stockpiles for concrete aggregates should be built up in a cone shape.

1. True
2. False

5-47. What condition results if the slope inside an overhead charging bin is less than 50 degrees?

1. Aggregates discharge too quickly
2. The bottom aggregates absorb too much water
3. Aggregates segregate when discharged
4. Aggregates combine too thickly

5-48. What is the primary function of the water used in a concrete mix?

1. It wets the aggregates so the cement will bind
2. It starts the hardening process (hydration) of the cement
3. It makes the mix workable
4. It prevents the cement from curing too fast

5-49. When an air-entraining agent is used at a site, it is added to what element of a cement mix?

1. The aggregate for the mix
2. The concrete granules for the mix
3. The water to be used in the mix
4. The cement to be used in the mix

5-50. Which of the following materials can be used to retard the set of a concrete mix?

1. Borax
2. Sugar
3. Salt
4. Each of the above

- 5-51. A total of how many cubic yards of concrete is required for a pad 60 feet in length, by 30 feet in width, with a depth of 4 inches and a waste factor of 10 percent?
1. 24.2
 2. 22.0
 3. 59.4
 4. 65.3
- 5-52. Batching by volume provides greater accuracy and avoids problems created by the bulking of damp sand.
1. True
 2. False
- 5-53. When mixing concrete in a transit mixer, what is the maximum number of revolutions of the drum at mixing speed that you should use?
1. 60
 2. 70
 3. 90
 4. 100
- 5-54. What is the minimum agitating speed on a transit mixer?
1. 1 revolution per minute
 2. 2 revolutions per minute
 3. 3 revolutions per minute
 4. 4 revolutions per minute
- 5-55. Concrete that is kept agitated can generally be placed within what maximum time period after mixing?
1. 3 1/2 hours
 2. 2 1/2 hours
 3. 1 1/2 hours
 4. 1/2 hour
- 5-56. On a mobile concrete mixer plant, the sand and aggregate are accurately proportioned according to what measurement(s)?
1. By cubic feet of material only
 2. By cubic yards of material only
 3. By weight or by cubic feet
 4. By weight or by volume
- 5-57. You are conducting a slump test. Which of the following results indicate a poor mix?
1. The concrete mix crumbles
 2. The concrete mix segregates
 3. The concrete mix falls apart
 4. Each of the above
- 5-58. When working around cement, you should pay particular attention to any rash on your skin because a rash may indicate cement poisoning.
1. True
 2. False
-
- Learning Objective: Describe the operations of an asphalt plant.
-
- 5-59. On a batch plant, the size of a batch varies according to the capacity of what component?
1. The hopper
 2. The dryer
 3. The pugmill
 4. The screens
- 5-60. The proper amount of aggregates for asphalt mixes is initially controlled by a uniform flow of the aggregate through what component?
1. Cold-feed adjustment
 2. Hot-feed adjustment
 3. Cold-bin capacity
 4. Hot-bin capacity
- 5-61. The overloading of the screens with aggregate underscores a need for control of what factor?
1. Proper dryer control
 2. Proper weigh-hopper calibration
 3. Proper cold feeding
 4. Proper gradation control calibration

- 5-62. The grading of an individual cold aggregate is determined by taking what action?
1. Matching a sample of aggregate with a previous marked sample
 2. Running a sieve analysis
 3. Measuring the rate of aggregate to the fines
 4. Noting the progressive thickness of the fines
- 5-63. Which of the following factors control the time required for aggregate to pass through a dryer?
1. The cylinder speed
 2. The slope of the cylinder
 3. The length, arrangements, and number of flights
 4. All of the above
- 5-64. When aggregate particles show signs of an oily coating after leaving the dryer, you should make what adjustment?
1. Decrease the amount of fuel oil
 2. Decrease blower or draft air pressure
 3. Increase the amount of fuel oil
 4. Increase the amount of natural gas
- 5-65. What factor controls the temperature of an asphalt mix?
1. The temperature of the asphalt
 2. The temperature of the dryer
 3. The temperature of the aggregates
 4. The temperature of the pugmill
- 5-66. If not kept clean, which of the following components can be a serious cause of air pollution at an asphalt plant?
1. Screens
 2. The dryer combustion unit
 3. The dryer
 4. The hopper
- 5-67. The Jet-Pulse system is used in an asphalt plant as a method to gain what result?
1. Production of pulses of heat to keep aggregate hot
 2. Production of suction pulses to control dust
 3. Production of a pulse of pressure within a filter bag to dislodge "dust cake"
 4. A method that produces a stream of hot asphalt onto aggregates
- 5-68. What factors determine the amount of dust from the dust collector that can be returned to the plant?
1. Moisture content
 2. Degree of suspension efficiency
 3. Mix specification
 4. Separate grading of the finish mix
- 5-69. In the gradation control unit, which of the following screens is used as a scalping screen?
1. Top screen
 2. Top intermediate screen
 3. Bottom intermediate screen
 4. Bottom screen
- 5-70. As associated with the gradation control unit, what does the term "carry-over" mean?
1. Larger aggregates are misdirected to smaller aggregate bins
 2. Rejected aggregates are "carried-over" to a discharge chute
 3. Smaller aggregates are misdirected into the larger aggregate bins
 4. Improperly heated aggregates are reheated

5-71. Bin partitions should have which of the following properties to prevent intermingling of the aggregates within the hot bins?

1. Be tight fitting
2. Be free of holes
3. Be of sufficient height
4. All of the above

5-72. In a continuous-flow plant, a sample of hot aggregate should be obtained from which of the following locations?

1. Scalping screens
2. Overflow vents
3. Feeder gates
4. Dryer

5-73. What function does the vertical slot in the asphalt return line serve in asphalt heating and circulation?

1. It breaks the vacuum in the line upon reversing the pump
2. It allows for circulation of asphalt through the feeding and storage system
3. It prevents oxidation of the asphalt
4. It provides a means of sampling asphalt

5-74. The temperature of the asphalt controls the temperature of an asphalt and aggregate mixture.

1. True
2. False

5-75. As part of an asphalt mix design, what is the purpose of the mineral filler?

1. To increase the weight of intermediate aggregate
2. To decrease the curing time of the asphalt mix
3. To increase the workability of the asphalt mix
4. To fill in the voids of the aggregates

ASSIGNMENT 6

Textbook Assignment: "Asphalt Plant Supervisor," and "Well Drilling Supervisor," pages 8-11 through 9-17.

Learning Objective: (continued):
Recognize the operations of an asphalt plant.

6-1. Using table 8-1, what is the distributor spraying temperature for asphalt emulsion SS-1h?

1. Between 50°F-140°F
2. Between 75°F-130°F
3. Between 110°F-160°F
4. Between 135°F-175°F

6-2. Final metering of mineral filler to a mix is accomplished through what device?

1. A variable speed vane
2. A screw feeder
3. A belt feeder
4. One of the above, depending on the material being handled

Learning Objective: Recognize the operational processes of a batch asphalt plant.

6-3. Which of the following units is a distinguishing feature of a batch asphalt plant?

1. The cold aggregate feed unit
2. The batching unit
3. The dryer unit
4. The dust collector unit

6-4. From the hot bins, what size aggregates are deposited into the weigh-hopper first?

1. Coarse
2. Intermediate
3. Fine
4. Mineral filler

6-5. A pugmill's "live zone" is the net volume in cubic yards below a line extending across the top arc of the inside body shell radius, with shafts, liners, paddles, and tips deducted.

1. True
2. False

6-6. In a batch asphalt plant, in what location do the aggregates, mineral filler, and asphalt get mixed together?

1. Dryer
2. Weigh-hopper
3. Pugmill
4. Asphalt weigh bucket

6-7. In what manual can the batch asphalt plant supervisor find details on the setup and adjustment of the automatic equipment?

1. NAVFAC Supervisory Instructions Manual
2. COMSECOND/COMTHIRDNCBINST Equipment Management Manual
3. Manufacturer operator's manual
4. Alfa company operations manual

Learning Objective: Recognize the operational processes of a continuous-flow asphalt plant.

6-8. What factor must be known at all times in order to maintain constant asphalt proportioning?

1. The temperature of the aggregate
2. The output temperature of the dryer
3. The temperature of the hot bins
4. The temperature of the asphalt

- 6-9. What are the characteristics of the movement of materials within a continuous-flow plant pugmill?
1. They are confined in the mixer chamber
 2. They are propelled toward discharge
 3. They are continuously mixed in the mixer chamber
 4. They are continuously mixed, weighed, then discharged
- 6-10. What period of time begins when all the combined mineral aggregates are in the mixer and ends when the gate is open?
1. The total mixing time
 2. The wet mixing time
 3. The dry mixing time
 4. The shortest mixing time
- 6-11. What period of time starts with the asphalt application and ends with the opening of the discharge gates?
1. The total mixing time
 2. The wet mixing time
 3. The dry mixing time
 4. The shortest mixing time
- 6-12. What environmental condition makes asphalt film harden on the aggregates?
1. Exposure to air
 2. Exposure to moisture
 3. Exposure to heat and air
 4. Exposure to moisture and air
- 6-13. Which of the following is NOT a part of the automatic control system for a continuous-flow plant?
1. Burner controls
 2. Mix discharge
 3. Dryer control
 4. Mixer and gradation cutoffs
- 6-14. In a drum-mix plant, in what location is aggregate mixed with the asphalt?
1. In the mix surge silo
 2. In the hot-mix conveyer
 3. In the dust collector
 4. In the dryer
- 6-15. The drum-mix plant gradation control unit proportions all the aggregate before it enters the mixing drum.
1. True
 2. False
- 6-16. What factor is the basis for determining the quantity of asphalt delivered into the drum?
1. The weight of the aggregate
 2. The gradation of the aggregate
 3. The drum-mix output requirement
 4. The speed of the in-line belt feeder
- 6-17. What section in a drum-mixer heats and dries the aggregate?
1. Primary
 2. Intermediate
 3. Secondary
 4. Third
- 6-18. What condition creates an oily coating on the aggregate particles?
1. Aggregate not heated
 2. An unbalanced distribution of asphalt
 3. A lack of balance in the burner operation
 4. Drum-mixer speed is too slow
- 6-19. The drum-mix plant produces a batch-flow of asphalt that can be temporarily stored in the surge silo.
1. True
 2. False

Learning Objective: Recognize the operational processes of a drum-mix asphalt plant.

Learning Objective: Identify the properties of bituminous surfacing materials.

6-20. What is/are the function(s) of the aggregates in a asphalt surface?

1. Transmits the load from the surface to the subgrade
2. Absorbs the abrasive wear of the traffic
3. Provides a nonskid surface
4. All of the above

6-21. Which of the following factors is required to support the bearing action on a bituminous wearing surface?

1. Larger aggregates placed in the mix design
2. Subgrade and base course must have adequate thickness, strength, cohesion, and bearing capacity
3. Upgrade the amount of asphalt in the mix
4. Give the mix adequate curing time

6-22. Which of the following is a bituminous surfacing material?

1. Emulsion
2. Tar
3. Asphalt bitumen
4. Each of the above

6-23. A container of bituminous material labeled with the symbol AC indicates it contains which of the following materials?

1. Asphalt cutback
2. Asphalt cement
3. Asphalt emulsion
4. Anionic-cationic asphalt

6-24. When used with asphalt cement, which of the following distillates allows for slow curing after application to a roadway?

1. Naphtha
2. Kerosene
3. Fuel oil
4. Gasoline

6-25. Which of the following viscosity grades of an MC asphalt bitumen is considered the most fluid?

1. 30 to 60
2. 200 to 800
3. 800 to 1,000
4. 1,000 to 3,000

6-26. When added to asphalt cement, which of the following produces an asphalt emulsion?

1. Water only
2. Soap only
3. Water and soap
4. Kerosene

6-27. What road tar symbol designates a hot tar?

1. RT 1
2. RT 2
3. RT 5
4. RT 9

Learning Objective: Recognize the test for identifying bituminous materials.

6-28. Field identification of bituminous materials found stockpiled in unmarked containers is necessary for which of the following reasons?

1. To determine the type and method of construction the material can be used for
2. To establish safe handling practices for the material
3. To determine type and quality of equipment needed
4. All of the above

- 6-29. Normally, what field test is used to differentiate between unknown bituminous materials?
1. Heat-odor
 2. Volubility
 3. Water-mixing
 4. Penetration
- 6-30. When you are performing the volubility test, what material will form a stringy undissolved mass?
1. Asphalt
 2. Asphalt cement
 3. Emulsion
 4. Tar
- 6-31. Asphalt cutbacks are fluid at room temperature.
1. True
 2. False
- 6-32. What grade of asphalt is indicated by a field test in which the sharp point of pencil penetrates the asphalt with difficulty?
1. Hard
 2. Medium
 3. Soft
 4. Medium hard
-
- Learning Objective: Recognize and compute estimates of materials.
-
- 6-33. What is the purpose of a prime coat?
1. Waterproof the surface
 2. Plug capillary voids
 3. Coat and bond loose particles
 4. All of the above
- 6-34. If the ROA is not known, what ROA is used in the NCF for planning purposes?
1. .1
 2. .2
 3. .3
 4. .4
- 6-35. How many gallons of prime coat is require for a project 2 miles long, 12 feet wide, waste factor of 5 percent, and a ROA of 0.3 gal/sq yd?
1. 4435.2 gal
 2. 5174.4 gal
 3. 6336 gal
 4. 7392 gal
- 6-36. What happens when a tack coat is applied too heavily?
1. Soaks into the surface material
 2. The overlying coarse will not stick to the surface coarse
 3. It will bleed into the overlying coarse
 4. It will cause the surface coarse to crumble
- 6-37. For the purpose of planning, what is the NCF ROA for a tack coat?
1. .10
 2. .15
 3. .20
 4. .25
- 6-38. A total of how many drums of tack coat material is required for a project 500 feet long, 50 feet wide, waste factor of 5 percent, and a ROA of .15?
1. 8.25 drums
 2. 11.79 drums
 3. 43.74 drums
 4. 82.54 drums
- 6-39. You are tasked with a single surface treatment of a road 20 miles long, 12 feet wide, and a waste factor of 10 percent. A 100-square/yard test strip showed that 2 tons of aggregate was used. What is the rate of application of aggregate in pounds per sq/yd?
1. 10
 2. 20
 3. 30
 4. 40

- 6-40. Using question 6-39, what total number of tons of aggregate is required for this task?
1. 1548.8
 2. 2323.2
 3. 3097.6
 4. 3872.2
- 6-41. Using equation 2, a total of how many pounds per square inch would a 4-inch asphalt mat equal?
1. 146
 2. 110
 3. 220
 4. 440
- 6-42. A total of how many tons of asphalt is required for a parking lot 120 feet long, 60 feet wide, 2 inches thick, with 5 percent waste factor?
1. 33
 2. 46
 3. 92
 4. 331
- 6-43. The required tonnage of hot-mix asphalt for a project is 300 tons. The screed of the paver is set at 12 feet, and the depth of asphalt is 2 inches. Estimate the amount of asphalt that can be laid per hour?
1. 34.68
 2. 80.46
 3. 96.55
 4. 102.4
- 6-44. When using the horn signal system, what does two blasts of the horn mean?
1. Stop
 2. Go forward
 3. Turn around
 4. Back up
- 6-45. In which underground zone, if any, should a water well be developed?
1. Plant zone
 2. Saturated
 3. Aeration
 4. None
- 6-46. Which of the following belts is NOT part of the zone of aeration?
1. Soil moisture
 2. Intermediate
 3. Saturation
 4. Capillary fringe
- 6-47. What is the name of the water contained in the zone of aeration?
1. Subsurface water
 2. Ground water
 3. Soil water
 4. Surface water
- 6-48. What formation is porous and permeable and can yield usable quantities of water?
1. Artesian
 2. Alluvial basin
 3. Aquifer
 4. Capillary fringe
- 6-49. An artesian well is a source of fresh water flowing freely from an aquifer in which the water pressure exceeds atmospheric pressure.
1. True
 2. False
- 6-50. Which of the following rock formations is most likely to produce water in usable quantities?
1. Igneous
 2. Sedimentary
 3. Alluvial
 4. Metamorphic

Learning Objective: Identify fundamentals of developing sources of ground water.

6-51. When nothing is known of the water resources in a particular area, the existence of water-producing formations can be verified by which of the following means?

1. Exploratory drilling
2. Inspecting outcrops of rock formations
3. Studying maps and documents
4. Each of the above

6-52. A "drilled" well is normally drilled to a depth of what number of feet?

1. 1,000
2. 1,500
3. 2,000
4. 2,500

Learning Objective: Recognize the operation of rotary drilling.

6-53. What type of drilling method is used in areas where ground formations are loose and unconsolidated?

1. Mud drilling
2. Air drilling
3. Down-hole-drilling
4. Percussion drilling

6-54. During rotary drilling, a rapid yet smooth penetration of the drill bit is an indication that the bit is entering a

1. bed of gravel
2. formation of fine sand
3. clay formation
4. consolidated formation

6-55. Of the crew members operating the rotary well-drilling rig, who has the responsibility for carrying out the overall drilling program?

1. The project supervisor
2. The tool pusher
3. The driller
4. The derrick hand

6-56. Personnel engaged in well-drilling operations should observe which of the following safety measures?

1. Wear tight fitting clothes while working around moving machinery
2. Wear gloves when handling wire rope or metal parts
3. Wear safety shoes and hard hats
4. All of the above

6-57. Which component of a kelly-drive rotary well-drilling rig is connected to the top joint of the drill pipe?

1. The hoisting plug
2. The kelly
3. The water swivel
4. The drill collar

6-58. Which of the following components of the kelly-drive rotary well-drilling rig controls the rate of feed to the drilling bit?

1. The kelly drum brake
2. The hoist drum
3. The drill collar
4. The rotating table

6-59. On the kelly-drive rotary well-drilling rig, what accessory holds the drill pipe securely during joint addition or removal?

1. The drill collar
2. The hoisting plug
3. The set of slips
4. The kelly sub

- 6-60. In the operation of the rotary drilling rig, what factors work together to prevent the walls of the drill hole from collapsing when the cut material is washed to the surface by a mixture of mud and water?
1. The filtering action of the coarse material in the settling pit
 2. The weight and viscosity and the plastering action of the fluid on the wall of the well hole
 3. The action of suspended local mud in the fluid and the additional weight of the fluid due to its content of suspended clay
 4. The suspension of cuttings in the settling pit and the spiraling of the fluid against the wall of the drill hole
- 6-61. What is considered the normal quantity of water needed to support an 8 hour shift of rotary well-drilling?
1. 100 to 500 gallons
 2. 500 to 750 gallons
 3. 750 to 1,000 gallons
 4. 1,000 to 4,000 gallons
- 6-62. What type of drill bit is used for drilling through a moderately hard surface formation with a rotary rig?
1. Pilot
 2. Roller
 3. Fishtail
 4. Three way
- 6-63. After the well hole has been drilled the length of the kelly, what accessory is placed to keep the well from caving in from the surface?
1. Turntable
 2. Surface casing
 3. Drill collar
 4. Set of slips
- 6-64. What depth is the top-head drive rotary well-drilling rig capable of rotary drilling?
1. 900 feet
 2. 1,000 feet
 3. 1,250 feet
 4. 1,500 feet
- 6-65. On the ITWD, what is the purpose of the split centralizer?
1. To break and make drill pipe connections
 2. To support the drill string during handling
 3. To aid in setting casings
 4. All of the above
- 6-66. What material is used to lubricate the top-head spindle sub threads?
1. Drilling lubricant
 2. Petroleum jelly
 3. Pipe dope
 4. Fish oil
- 6-67. When performing down-hole-drilling operations, how is the oil flow checked?
1. Inspecting the oil pattern on a piece of card board that is placed under the spindle
 2. Checking the amount of oil on the cuttings
 3. Placing your hand under the hammer and inspecting the amount of oil discharged
 4. Disconnecting the flushing hose and inspecting the amount of oil discharged from the hose

Learning Objective: Recognize drilling difficulties and the development of a water well.

- 6-68. One method of regaining a loss of circulation that takes place during well drilling is to circulate the cuttings away from the drill bit with plenty of water.
1. True
 2. False
- 6-69. Undue wear of the drill pipe is an indication of a crooked drill hole.
1. True
 2. False
- 6-70. During a drilling operation, the drill pipe may stick due to which of the following causes?
1. A mud pump of inadequate capacity
 2. Allowing the drill pipe to stop and remain stationary in the hole
 3. Mud balling up around the drill collar and bit
 4. All of the above
- 6-71. The drill pipe of your rotary well-drilling rig becomes stuck with drill cuttings that have accumulated in the hole. How can you remedy the situation?
1. Pull upward on the pipe with jacks
 2. Circulate heavy mud while trying to turn the pipe
 3. Pour oil along the sides of the pipe
 4. Pull upward on the pipe and circulate clear water around it
- 6-72. Which of the following is a practical use of a fishing tool?
1. Recovery of a twisted-off drill pipe
 2. Recovery of a wrench that falls into the drill hole
 3. Recovery of a drill pipe that falls into the drill hole
 4. Each of the above
- 6-73. The setting of the casing and screens is the first operation in developing a well after the borehole is drilled.
1. True
 2. False
- 6-74. Gravel packing is placing ungraded aggregate on the outside of the casing to allow for more production and prevent fines from entering the well pump.
1. True
 2. False
- 6-75. In completing a developed well, the space between the well wall and casing is cemented to
1. trap the drilling mud below the water table
 2. keep surface water or contaminated water from seeping into the aquifer
 3. prevent the drilling mud from solidifying
 4. All of the above

